

MicroMetl

ISOLATION CURB

CATALOG

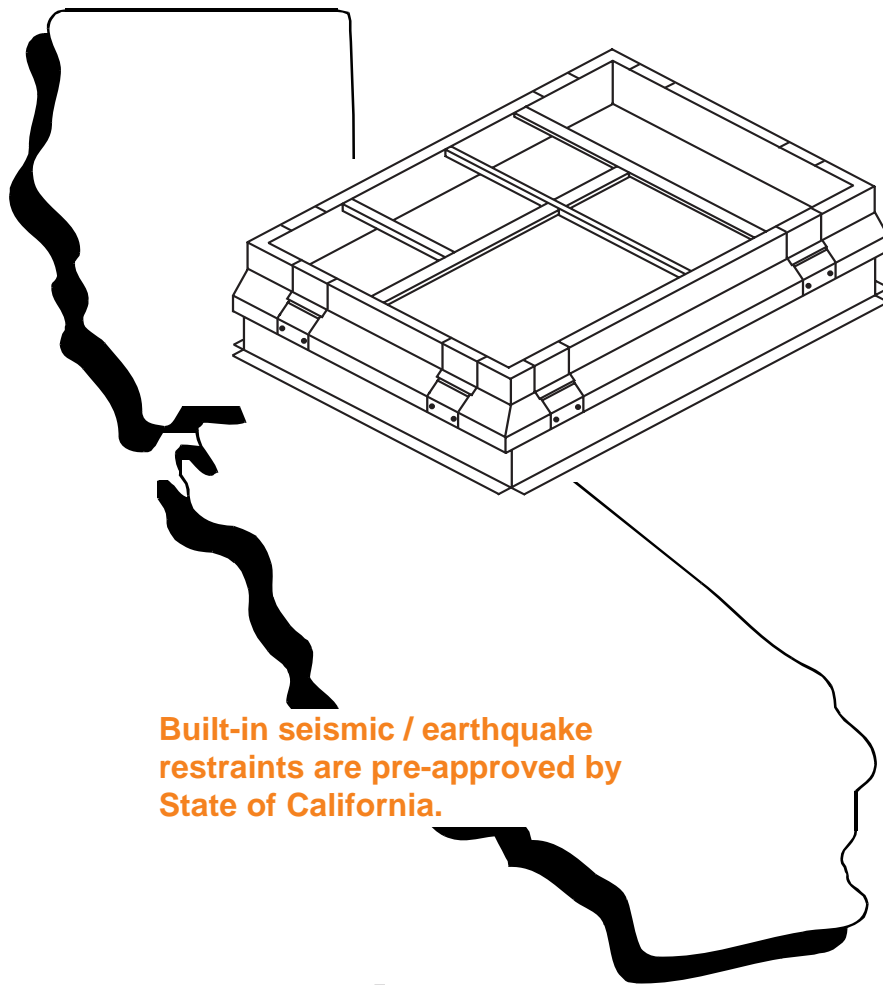

Built-in seismic / earthquake restraints are pre-approved by State of California.

**for 0402-622A
Isolation Curb with
Seismic / Earthquake Restraints**

**for York
DH,DM,BP 180;
BCH 180; DCG
180; DEE 180;
DEG 180; DCE**





MicroMetl 0402-622A Curb Specifications

For York
DH,DM,BP 180; BCH 180;
DCG 180; DEE 180; DEG
180; DCE

CONTENTS

Specifications	2
Curb Specifications	3
Spring Detail & Approval ..	4
Engineering Calculations part one	5
Engineering Calculations part two	6
Installation Instructions	7

- 1.) Springs shall be preapproved by the California Office of Statewide Health Planning and Development.
- 2.) Spring application and anchorage method shall be approved by Registered Professional Engineer State of California.
- 3.) Springs shall include built in seismic / earthquake restraints - California approved.
- 4.) Springs shall be accurately selected (sized) based on each corner weight of HVAC unit. Isolation curb manufacturers using same spring size in all corners, regardless of actual corner weight, **shall not** be accepted.
- 5.) Isolation curb shall allow for field adjustment of each spring through gasketed, watertight access doors.
- 6.) Isolation curb shall be fully assembled and shipped on a skid / crate.
- 7.) Bulb seal shall be installed between spring housing and bottom curb. Seal shall be manufactured by Elgin.
- 8.) Isolation curb shall be constructed of galvanized steel with welded assembly. Spring housing - 20 gauge, bottom curb - 16 gauge.

Spring
approved by the
state of
California

Important Information

MicroMetl's 0402-622A Isolation Curbs are equal to or exceed specifications written for:

Approximate weight of isolation roof curb: 630 lbs.

- MASON INDUSTRIES RSC and ISC series.
- CANFAB Isocurb series.
- THYCURB Vibrocurb.
- M.W. Sausse VIC - EQ series

Order Today From MicroMetl

Indianapolis, IN 1-800-662-4822
Sparks, NV 1-800-884-4662



CALIFORNIA DYNAMICS CORP.
 5572 ALHAMBRA AVE.
 LOS ANGELES, CA. 90032-3106

CALL US - TO SET THINGS RIGHT
 PH (323) 223 - 3882
 FAX (323) 223 - 7941
 email: caldyn@earthlink.net

TYPE JQ
 ISOLATOR/RESTRAINTS
 WITH/CALIF. PRE-APPROVED
 SEISMIC PROTECTION
 OPA - 0070
 2" DEFLECTION
 FILE 309 1/18/04

JOB: _____
 CUST: _____
 ENGR: _____
 TAG: _____

DATE: _____

OPA - 0070 PRE - APPROVED MAXIMUM ALLOWABLE LOADS		
SIZE	HORIZ.	VERT.
JQA	800	1600
JQB	1000	1800
JQBx	1500	2000
JQE	3200	4300
JQF	2900	4000

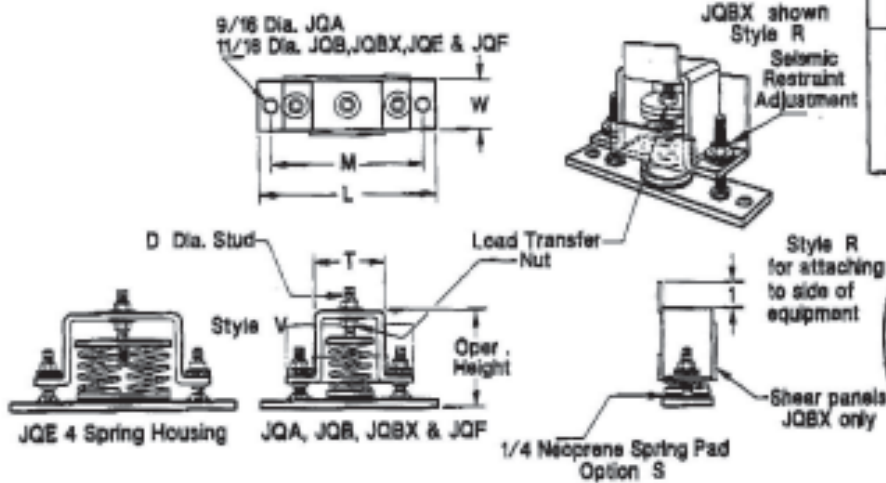

Isolator Selection & Loc.

RATED LOAD & P/N			
F Springs 2" Deflection			
JQA Size	JQB Size JQBx Size	JQE Size	JQF Size
F58	F348	F832	F1108
F83	F487	F480	F1408
F100	F580	F820	F1710
F155	F876	F780	F2148
F195	F825	F944	F2700
F236	F918	F1200	
F300			



TYPICAL CALLOUT:



Housing Size	L	W	M	T	D	Approximate Oper. Height
JQA	7	2	6	2 - 3/4	3/8	4 - 1/2
JQB/JQBx	10-1/2	3-1/2	9	4	5/8	5 - 1/2
JQE	14	5	12	6	5/8	5
JQF	14	5	12	5 - 3/4	5/8	8

Surface Treatment:
 Housings Hot Dip Galvanized (HDG)
 Hardware Zinc Plated
 Springs Powder Coated or Zinc Plated.
 Dimensions in Inches . Loads in Pounds .

Adjust Load Transfer Nut for Proper Operation .

All JQ Isolator/Restraints feature large diameter springs with O. D. equal or greater than 80% of rated load height .

For compact support of heavy loads, many JQ's include inner springs. For Low profile support of heavy Loads , JQE's have clustered springs .

Fax in your order to MicroMetl
Indianapolis, IN 1-317-543-5986
Sparks, NV 1-775-356-9184



MicroMetl 0402-622A Curb Specifications

For York
DH,DM,BP 180; BCH 180;
DCG 180; DEE 180; DEG
180; DCE

Isolation Curb Features

- Package includes roofcurb and isolation fully assembled with welded seams.
- Isolation springs have built-in seismic / earthquake restraints approved by the State of California.
- Spring application and anchorage method approved by Registered Professional Engineer in State of California.
- Springs are adjustable through watertight access doors.
- Wood nailer, gasketing package included.
- Tight weather seal between roofcurb and spring housing.
- Shipped on a skid/ crate.

Specific

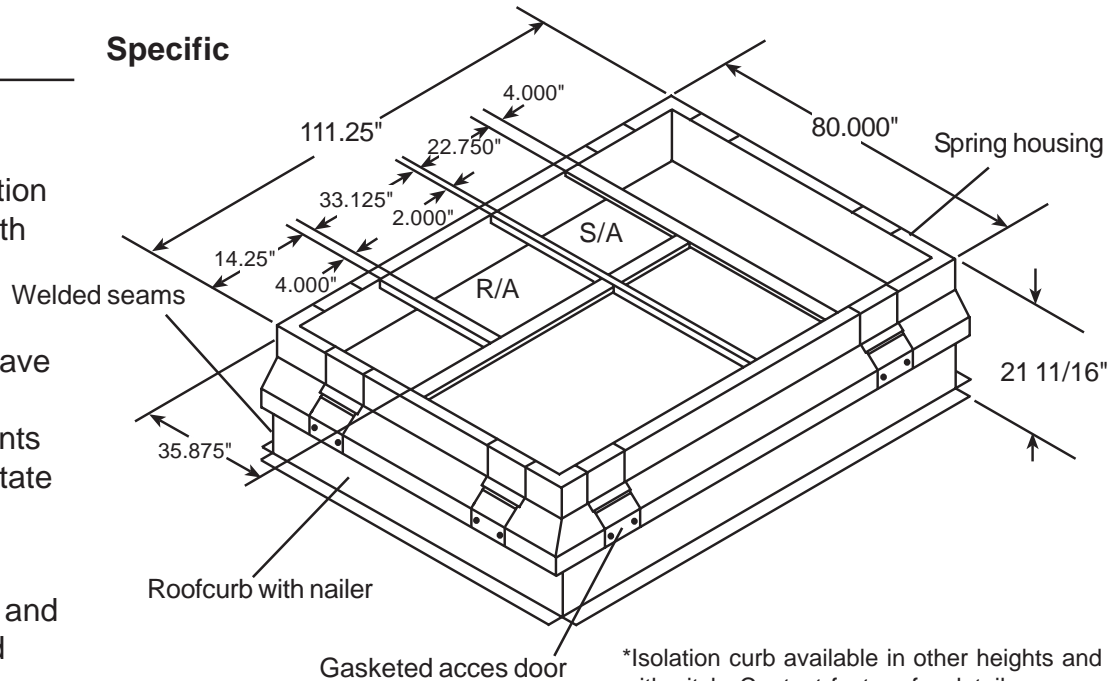

*Isolation curb available in other heights and with pitch. Contact factory for details.
*21 11/16" height is without load of unit.
With unit in place curb height is approx. 21".

General

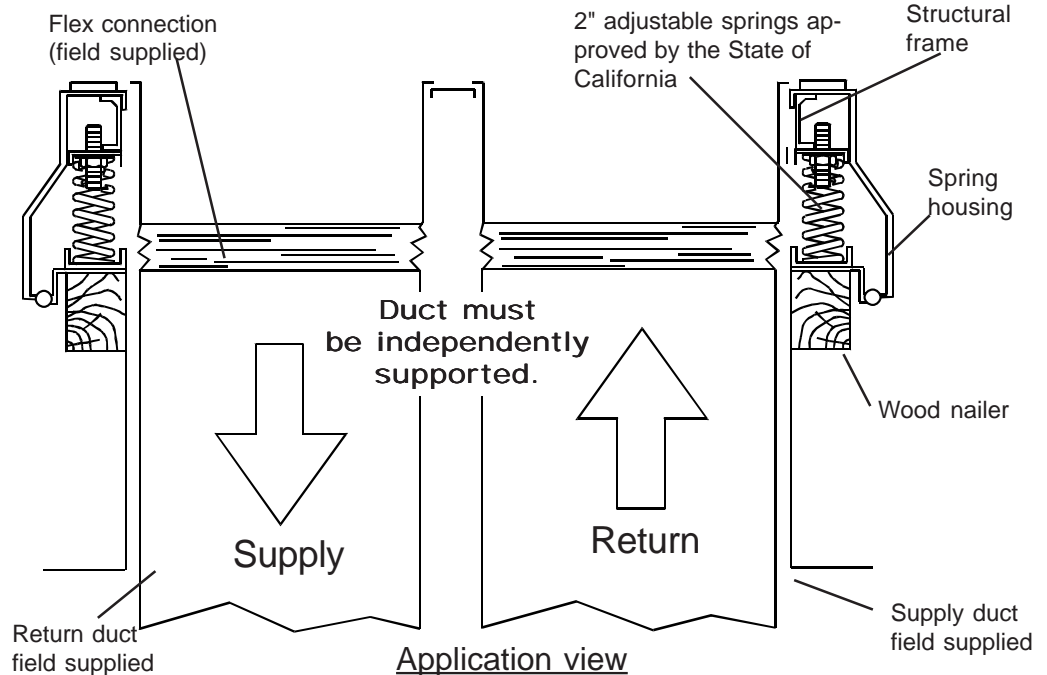

Order Today From MicroMetl

Indianapolis, IN 1-800-662-4822
Sparks, NV 1-800-884-4662

CALDYN
 CALIFORNIA DYNAMICS CORP.
 5572 ALHAMBRA AVENUE
 LOS ANGELES, CA 90032
 PHONE: (323) 223 3882
 FAX: (323) 223 7941

JOHN A. MARTIN & ASSOCIATES, INC.
 STRUCTURAL ENGINEERS
 1212 S. Flower St., L.A., CA 90015
 JAMA JOB NO. 11321.222

STRUCTURAL INTEGRITY
 OF
 RESTRAINING ELEMENTS
 FOR
 EARTHQUAKE PROTECTION
PART 1: ISOLATOR RESTRAINT



Date : 8/3/2007
 Job Name :
 Customer : MICROMETL
 Equipment Tag : 0402-622A, 0402-652A
 Weight, lbs : 3,085.00
 Code :
 Horizontal Cph : 1
 Vertical Cpv : 0.33
 Isolator Restraint : JQA-
 Deflection, in. : 2"
 Restraint quantity : 14
 X-Rating, lbs : 800.00
 Y-Rating, lbs : 800.00
 Z-Rating, lbs : 1,660.00
 Rating Basis : OSHPD PRE-APPROVAL OPA-0070

Remarks/ Detail:

SCHEMATIC OF EQUIPMENT

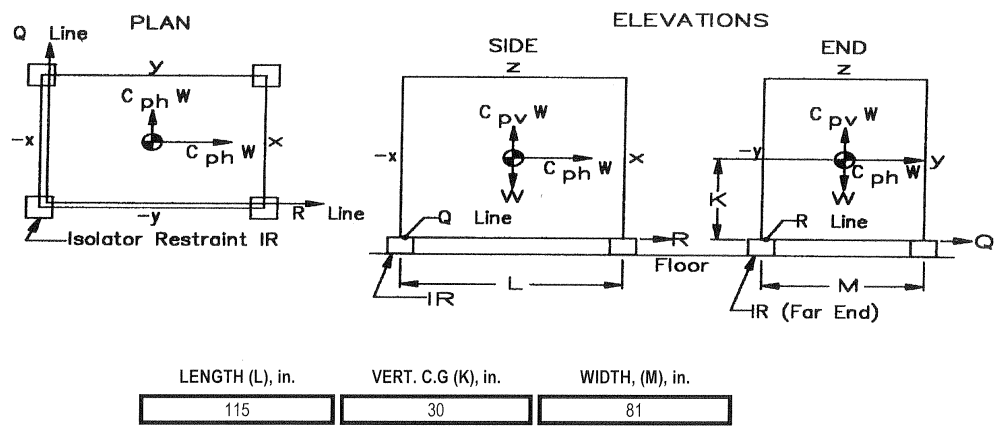

Safety Factors > 1.0

Horizontal X-X Shear Load (Cph x W)
 X-X Load = Load / Restraint = (3085/14) = 220.36
 X-X Rating / X-X Load = 800 / 220.36 = **3.63**

Horizontal Y-Y Shear Load (Cph x W)
 Y-Y Load = Load / Restraint = (3085/14) = 220.36
 Y-Y Rating / Y-Y Load = 800 / 220.36 = **3.63**

Vertical pullout at IR along the Q Line
 quantity of Restr on Q Line, q = 2
 Uplift, ((Cpv x W) / T) = (0.33 x 3085) / 14 = 73
 Pri Overturn (Cph x W x K) / (L x q) = (1 x 3085 x 30) / (115 x 2) = + 402
 Pullout Load = 475
 Pullout Rating / Pullout Load = 1660 / 475.11 = **3.49**

Vertical Pullout at IR along the R Line
 quantity of Restr on R Line, r = 7
 Uplift, ((Cpv x W) / T) = (0.33 x 3085) / 14 = 73
 Pri Overturn (Cph x W x K) / (M x r) = (1 x 3085 x 30) / (81 x 7) = + 163
 Pullout Load = 236
 Pullout Rating / Pullout Load = 1660 / 235.95 = **7.04**

Calcs. I.D. :

Fax in your order to MicroMetl
Indianapolis, IN 1-317-543-5986
Sparks, NV 1-775-356-9184



CALIFORNIA DYNAMICS CORP.
 5572 ALHAMBRA AVENUE
 LOS ANGELES, CA 90032
 PHONE: (323) 223 3882
 FAX: (323)223 7941

JOHN A. MARTIN & ASSOCIATES, INC.
 STRUCTURAL ENGINEERS
 1212 S. Flower St., L.A., CA 90015
 JAMA JOB NO. 11321.222



STRUCTURAL INTEGRITY
 OF
 RESTRAINING ELEMENTS
 FOR
 EARTHQUAKE PROTECTION
PART 2: ANCHORAGE

Date : 8/3/2007
 Job Name :
 Customer : MICROMETL
 Equipment Tag : 0402-622A, 0402-652A
 Weight, lbs : 3085 Horizontal Cph : 1
 Code : Vertical Cpv : 0.33
 Remarks/ Detail :
 Anchorage : 2", 1/8" FILLET WELD
 Use special inspection : NO
 Anchor quantity : 28
 Tension Allow., lbs : 1,200.00
 Shear Allow., lbs : 1,200.00
 Substrate : STEEL
 Substrate rating, psi : N/A
 Rating Basis : BLODGETT

SCHEMATIC OF ISOLATOR RESTRAINT IR ELEVATIONS

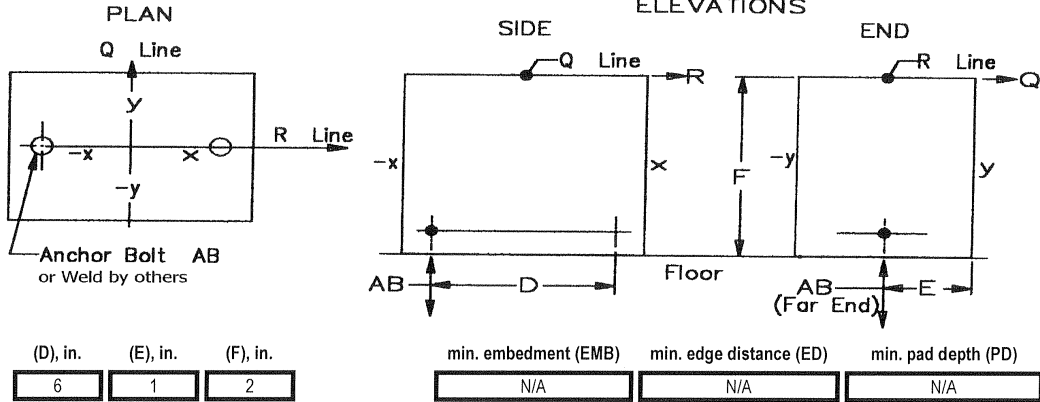

** Safety Factors

Horizontal Shear Load (Cph x W) = (1 x 3085) = 3085 Anchor Qty, (2 x T) = 2 x 14 = 28
 (Load/AnchorQty) = 3085/28 = 110.18 Shear Rating/Shear Load = 1200/110.18 = 10.89

Vertical Pullout at Anchor AB Resulting From X-X Load
 Uplift ((ACpv-0.9) x W) / (2 x T) = (0.33-0.9) x 3085 / (2 x 14) = -62.80
 Pri Overturn (ACph x W x K) / (2 x L x q) = (1 x 3085 x 30) / (2 x 115 x 2) = + 201.20
 Sec Overturn (ACph x W x F) / (1 x D x T) = (1 x 3085 x 2) / (1 x 6 x 14) = + 73.45
 Pullout Load = 211.85
 Pullout Rating / Pullout Load, (1200 / 211.85) = 5.66

Vertical Pullout at Anchor AB Resulting From Y-Y Load
 Uplift ((ACpv-0.9) x W) / (2 x T) = (0.33-0.9) x 3085 / (2 x 14) = -62.80
 Pri Overturn (ACph x W x K) / (2 x M x r) = (1 x 3085 x 30) / (2 x 81 x 7) = + 81.61
 Sec Overturn (ACph x W x F) / (2 x E x T) = (1 x 3085 x 2) / (2 x 1 x 14) = + 220.36
 Pullout Load = 239.00
 Pullout Rating / Pullout Load, (1200 / 239) = 5.02

Sum of Reciprocals of Shear and Pullout Safety Factors = (1/10.89) + (1/5.66) = 0.27
 COMBINED LOADING to be less than 1.00 = (1/10.89) + (1/5.02) = 0.29

Calcs_I.D.:

Order Today From MicroMetl
Indianapolis, IN 1-800-662-4822
Sparks, NV 1-800-884-4662

MicroMetl
0402-622A
Installation Instructions

For York
 DH,DM,BP 180; BCH 180;
 DCG 180; DEE 180; DEG
 180; DCE



Instructions

Please read completely

1. Remove isolation curb from skid.
2. Hoist isolation curb to the roof.
3. Cut roof opening per HVAC unit instructions.
4. Set curb in place over opening. Secure to roof structure.
5. Roof-in bottom curb section up to wood nailer. See detail and follow all local roofing codes.
6. Install starter ducts with flex connection into duct opening on curb. Flex connection will eliminate vibration through duct work. Independently support the duct work.
7. Gasket top perimeter and duct opening on curb.
8. Set HVAC unit in place. Install any accessories (i.e. economizer) at this time.
9. MicroMetl 0402 Isolation Curbs have springs selected specifically for the HVAC unit. Remove spring access doors in each corner. The spring housing should ride at least 1/4" above the base (see detail). If the spring housing is riding less than 1/4" above the base, adjust the transfer nut clockwise (when looking down on spring) until the 1/4" is achieved. Adjust all springs in the same manner. If a spring housing will not come up off the base, it may be necessary to rotate other springs counter-clockwise to transfer weight off the overloaded spring. Adjust the nut for motion stabilizer until it sets 1/8" above the rubber washer (see detail).
10. Replace doors and continue a standard unit installation.

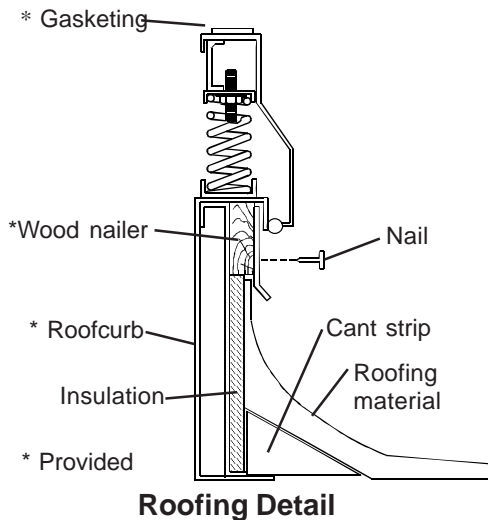
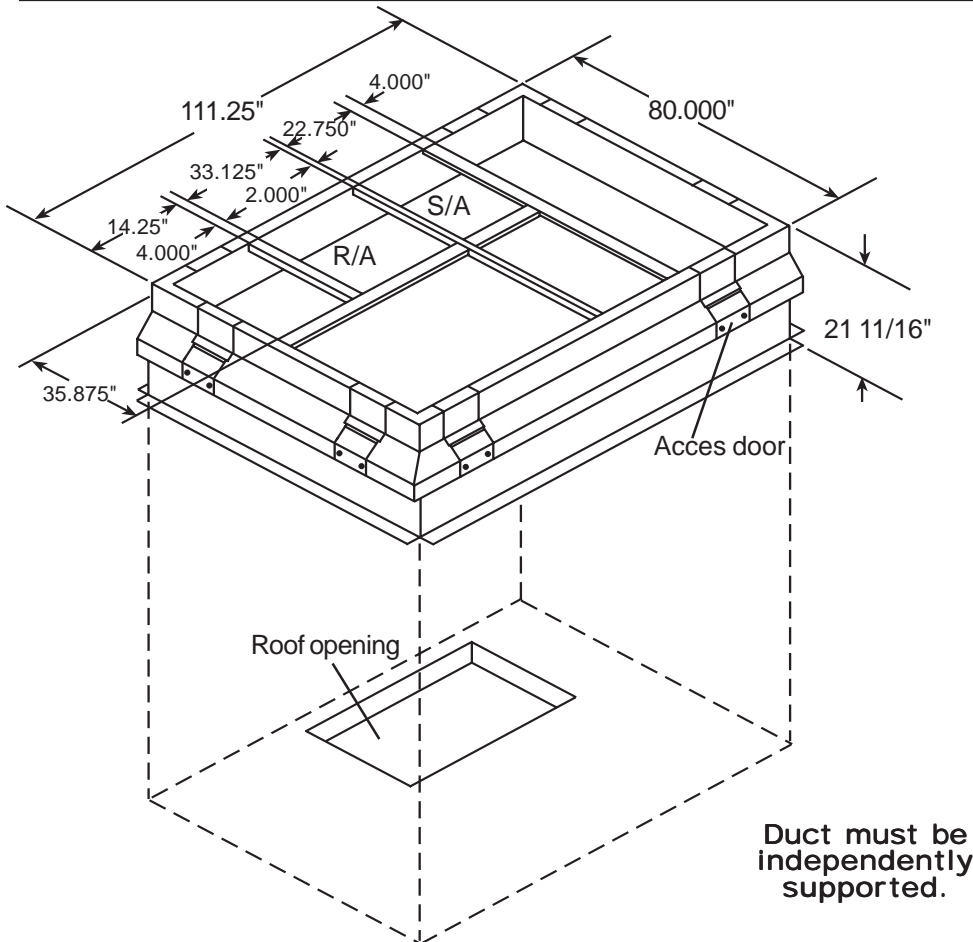

Roofing Detail

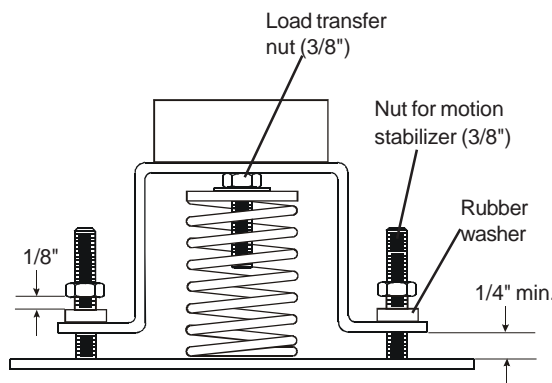

Spring Adjustment Detail

Fax in your order to MicroMetl
Indianapolis, IN 1-317-543-5986
Sparks, NV 1-775-356-9184



MicroMetl Indianapolis

3035 North Shadeland Ave.
Suite 300
Indianapolis, IN 46226
(Toll-free) 1-800-662-4822
(Fax) 1-317-543-5986

MicroMetl West

905 Southern Way
Sparks, NV 89431
(Toll-free) 1-800-884-4662
(Fax) 1-775-356-9184