

 **YORK**<sup>®</sup>

**MAXE**<sup>™</sup>

**Model YST**  
**Steam-Turbine Drive Centrifugal**  
**Liquid Chillers**  
**Design Level F**

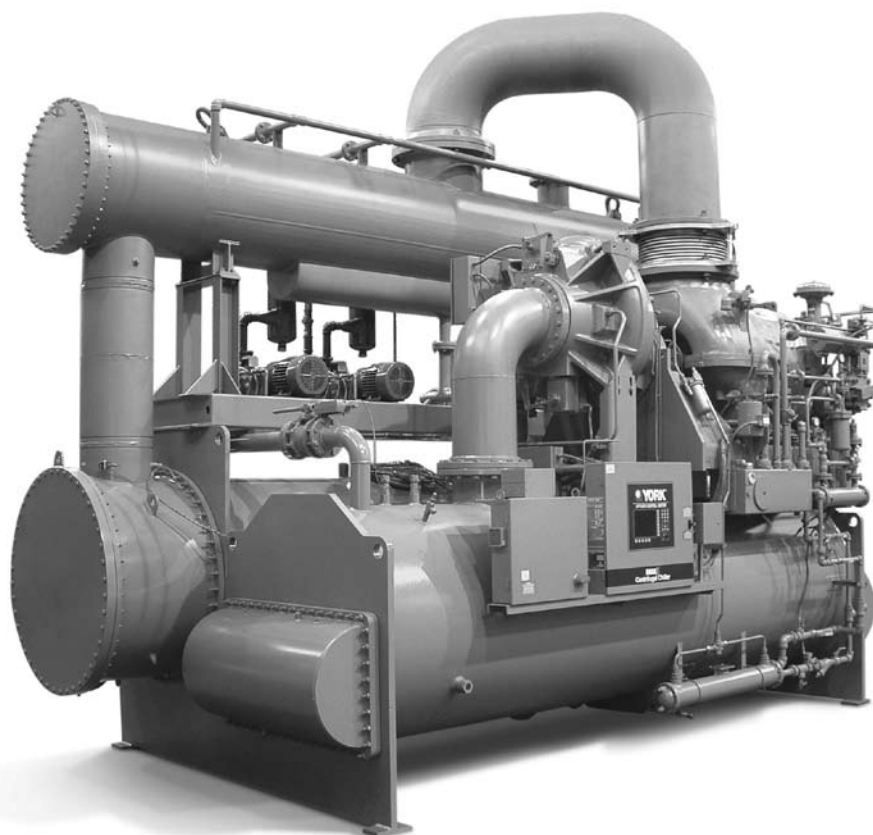

**700 Through 2165 TR**  
**(2500 Through 7400 kW)**  
**Utilizing HFC-134a**



## TABLE OF CONTENTS

Introduction.....	3
Ratings .....	5
OptiView Control Center.....	6
Equipment Specifications.....	7
Accessories and Modifications.....	12
Application Data.....	14
Dimensions (Ft. - In.) – H Compressor Units.....	19
Dimensions (Ft. - In.) – Nozzle Arrangements:	.
Evaporators – Compact Water Boxes – H Compressor Units.....	20
Evaporators – Marine Water Boxes – H Compressor Units.....	21
Refrigerant condensers – Marine Water Boxes – H Compressor Units.....	22
Dimensions (Ft. - In.) – J Compressor Units.....	24
Dimensions (Ft. - In.) – Nozzle Arrangements: .	.
Evaporators – Compact Water Boxes – J Compressor Units.....	26
Evaporators – Marine Water Boxes – J Compressor Units.....	27
Refrigerant condensers – Marine Water Boxes – J Compressor Units.....	28
Steam Condenser.....	30
Approximate Unit Weights (Lbs.).....	31
Marine Water Box Weight Additions (Lbs.).....	32
Dimensions (mm) H Compressor Units.....	33
Dimensions (mm) Nozzle Arrangements:	.
Evaporators – Compact Water Boxes – H Compressor Units.....	34
Evaporators – Marine Water Boxes – H Compressor Units.....	35
Refrigerant condensers – Marine Water Boxes – H Compressor Units.....	36
Dimensions (mm) J Compressor Units.....	38
Dimensions (mm) Nozzle Arrangements:	.
Evaporators – Compact Water Boxes – J Compressor Units.....	40
Evaporators – Marine Water Boxes – J Compressor Units.....	41
Refrigerant condensers – Marine Water Boxes – J Compressor Units.....	42
Approximate Unit Weights (Kg).....	45
Marine Water Box Weight Additions (Kg).....	46
Guide Specifications.....	47
SI Metric Conversions.....	56

## NOMENCLATURE

The model number denotes the following characteristics of the unit:

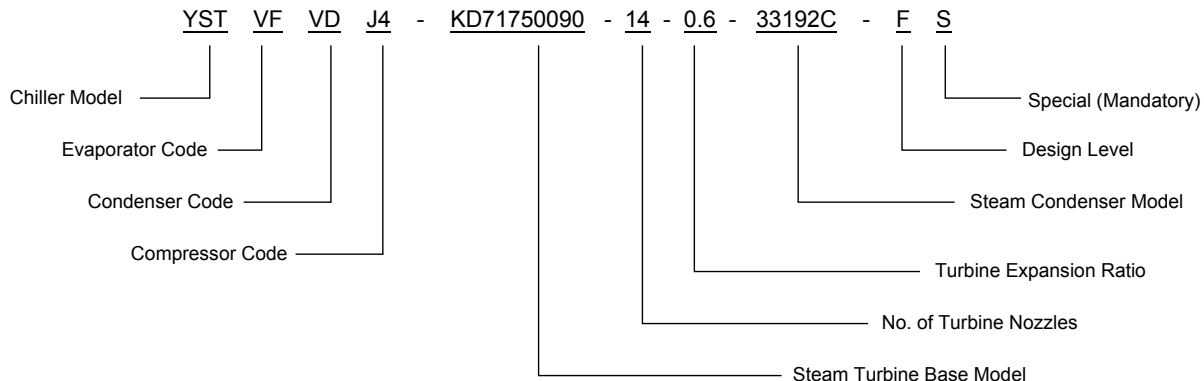

# Introduction

The YORK YST MaxE™ Chillers offer a complete combination of features for total owner satisfaction.

## MATCHED COMPONENTS MAXIMIZE EFFICIENCY

Overall chiller efficiency cannot be determined by analyzing the theoretical efficiency of any one chiller component. It requires a specific combination of heat exchanger, compressor, steam turbine and steam condenser performance to achieve the lowest system steam rate. YORK YST MaxE chiller technology matches chiller system components to provide maximum chiller efficiency under actual - not just theoretical - operating conditions.

## REAL-WORLD ENERGY PERFORMANCE

YORK pioneered the term “Real-World Energy” to illustrate the energy-saving potential of focusing on chiller performance during off-design conditions. Off-design is not only part load, but full load operation as well, with reduced entering refrigerant condenser water temperatures (ECWTs). This is where chillers operate 99% of the time, and where operating costs add up.

The YST MaxE chillers are the only chillers designed to operate on a continuous basis with cold ECWT and full refrigerant condenser flow at all load points, taking full advantage of Real-World conditions. This type of operation benefits the cooling tower as well; reducing cycling of the fan motor and ensuring good coverage of the cooling fill.

YORK YST MaxE chillers offer the most efficient Real-World operation of any chiller, meaning lower operating costs and an excellent return on your chiller investment.

## OPEN DRIVE DESIGN

YORK YST MaxE centrifugal chillers utilize an open drive compressor that enables the use of various drives. Specifically, the YST uses a Steam Turbine to provide the rotational power to drive the chiller. The use of steam as the motive energy provides owners the ability to take advantage of the most effective energy source available either by using steam only or by complementing this with other “hybrid” energy sources such as electric or gas.

## HIGH-EFFICIENCY HEAT EXCHANGERS

YST MaxE chiller heat exchangers offer the latest technology in heat transfer surface design to give maximum efficiency and compact design. Water, refrigerant and steam side design enhancements minimize both energy consumption and tube fouling.

## SINGLE-STAGE COMPRESSOR DESIGN AND EFFICIENCY PROVEN IN THE MOST DEMANDING APPLICATIONS

Designed to be the most reliable chillers we’ve ever made, YORK YST MaxE centrifugal chillers incorporate single-stage compressor design. With fewer moving parts and straightforward, efficient engineering, YORK single-stage compressors have proven durability records in hospitals, chemical plants, gas processing plants, the U.S. Navy, and in other applications where minimal downtime is a crucial concern.

In thousands of installations worldwide, YORK single-stage compressors are working to reduce energy costs. High strength aluminum-alloy compressor impellers feature backward-curved vanes for high efficiency. Airfoil shaped pre-rotation vanes minimize flow disruption for the most efficient part load performance. Precisely positioned and tightly fitted, they allow the compressor to unload smoothly from 100% to minimum load for excellent operation in air conditioning applications.

## MURRAY STEAM TURBINES - PROVEN EXPERIENCE AND HIGH EFFICIENCY

The YORK compressor, driven by a Murray Turbomachinery multistage steam turbine provides the best combination of optimized efficiency and proven track record. Murray multistage turbines are used together with innovative, automated controls to integrate the turbine and compressor seamlessly. The ability of the steam turbine to vary rotational speed provides optimal compressor efficiency at all operating conditions and builds on YORK’s reputation for the best in “Real-World Energy”. Optional automated start and shutdown controls eliminate the traditional manual intervention associated with steam turbine systems.

## FLEXIBILITY OF AN ITT STEAM CONDENSER PACKAGE

Unique to the YST chiller is the packaging of a steam condenser suitable for mounting on the chiller or alongside depending on site requirements. By designing the steam condenser for mounting on the chiller the YST footprint is no larger than that of traditional chillers saving space and simplifying plant layout when the YST chiller is used in combination with other YORK chillers. The same steam condenser package may be installed off the chiller, if required, without modification or eliminated altogether where a steam condensation system already exists on site.

# Introduction (continued)

---

## **PRECISION CONTROL OF COMPRESSOR OIL PRESSURE**

Utilizing our expertise in variable speed drive technology and applications, YORK has moved beyond the fixed head and bypass approach of oil pressure control. The old approach only assures oil pressure at the outlet of the pump rather than at the compressor, and allows no adjustment during chiller operation. The YST **MaxE** chillers feature a variable speed drive oil pump, monitoring and providing the right amount of oil flow to the compressor on a continuous basis. This design also provides sophisticated electronic monitoring and protection of the oil pump electrical supply, ensuring long life and reliable operation of the oil pump motor. Variable speed drive technology reduces oil pump power consumption, running only at the speed required, rather than at full head with a pressure regulating bypass valve.

## **FACTORY PACKAGING REDUCES FIELD LABOR COSTS**

YORK YST **MaxE** centrifugal chillers are designed to keep installation costs low. Where installation access is not a

problem, the chiller can be shipped completely packaged with steam turbine driveline factory installed. The steam condenser is a modular design, packaged to facilitate site installation on top of the refrigerant condenser or floor mounted adjacent to the chiller, either arrangement requiring minimal piping to complete the installation. The entire system requires a single point power connection to minimize on site wiring.

## **TAKE ADVANTAGE OF COLDER COOLING TOWER-WATER TEMPERATURES**

YORK YST **MaxE** centrifugal chillers have been designed to take full advantage of colder cooling tower water temperatures, which are naturally available during most operating hours. Considerable energy savings are available by letting tower water temperature drop, rather than artificially holding it above 75°F (24°C), especially at low load, as some chillers require.

# Ratings

---

## COMPUTERIZED PERFORMANCE RATINGS

Each chiller is custom-matched to meet the individual building load and energy requirements. A large number of standard heat exchangers and pass arrangements are available to provide the best possible match.

It is not practical to provide tabulated performance for each combination, as the energy requirements at both full and part load vary significantly with each heat exchanger and pass arrangement. Computerized ratings are available through each YORK sales office. These ratings can be tailored to specific job requirements.

## OFF-DESIGN PERFORMANCE

Since the vast majority of its operating hours are spent at off-design conditions, a chiller should be chosen not only to meet the full load design, but also for its ability to perform efficiently at lower loads and lower tower water

temperatures. It is not uncommon for chillers with the same full load to have an operating cost difference of over 10% due to part-load operation.

Part load information can be easily and accurately generated by use of the computer. And because it is so important to an owner's operating budget, this information has now been standardized in the form of an Integrated Part Load Value (IPLV), and Non-Standard Part Load Value (NPLV). The IPLV / NPLV formulas, in accordance with ARI Standard 550/590 guidelines, much more closely track actual chiller operations. A more detailed analysis must take into account actual building load profiles, and local weather data. Part load performance data should be obtained for each job using its own design criteria.

# Optiview Control Center

---

## YST OPTIVIEW CONTROL CENTER

The YORK OptiView Control Center, furnished as standard on each chiller, provides the ultimate in efficiency, automation, monitoring, data recording, chiller protection and operating ease. The Control Center is a factory-mounted, wired and tested state-of-the-art microprocessor based control system for R134a centrifugal chillers. The panel is configured with a 10.4" diagonal color Liquid Crystal Display (LCD) surrounded by "soft" keys, which are redefined with one keystroke based on the screen displayed at that time. This revolutionary development makes chiller operation quicker and easier than ever before. Instead of requiring keystroke after keystroke to hunt for information on a small monochrome LCD screen, a single button reveals a wide array of information on a large, full-color illustration of the appropriate component, which makes information easier to interpret.

The LCD display allows graphic animated display of the chiller, chiller sub-systems and system parameters; this allows the presentation of several operating parameters at once. The novel use of on screen animation enables operators to more readily identify component status. In addition, the operator may view a graphical representation of the historical operation of the chiller as well as the present operation. A Status Bar is displayed at all times on all screens. It contains the System - Status Line and Details Line, the Control Source, Access Level, Time and Date. During turbine slow roll, startup, operation and coast-down, the system status will indicate vital information available at any time. The locations of various chiller parameters are clearly marked and instructions for specific operations are provided on many of the screens. Data can be displayed in either English or SI units.

Security access is provided to prevent unauthorized changes of setpoints. This is accomplished with three different levels of access and passwords for each level. There are certain screens, displayed values, programmable setpoints and manual controls not shown that are for servicing the chiller. They are only displayed when logged in at service access level. Included in this is the Advanced Diagnostics and troubleshooting information for the chiller and the panel.

The control center power supply is provided from a fused 2 KVA transformer located in the power panel.

The control center is also fused to provide individual over-current protected power for the remote mounted water pump motor starters (supplied by others) and the controls installed on the chiller. Numbered terminal strips for wiring such as Remote Start / Stop, Chilled Water Pump and Local or Remote Cycling devices are provided. The Panel also provides field interlocks that indicate the chiller

status. These contacts include a Remote Mode Ready-to-Start, a Controlled Shutdown, a Safety Shutdown and a chiller Run contact. System pressures are monitored with transmitters (4-20 mA) and transducers (0-5 VDC). System temperatures are monitored using thermistors and RTD's.

Setpoints can be changed from a remote location via 0-10VDC and 4-20mA, contact closures or through serial communications. The adjustable remote reset range [up to 20°F (11.1°C)] provides flexible, efficient use of remote signal depending on reset needs. Serial data interface to the YORK ISN Building Automation System (BAS) is through the optional Microgateway Card, which can be mounted inside the Control Center. Interfaces using other industry standard protocols such as MODBUS RTU, Johnson NZ, BACnet MS/TP, LONMARK and ASCII are available.

The operating program is stored in non-volatile memory to eliminate chiller failure due to AC power failure/battery discharge. Programmed setpoints are retained in lithium battery-backed RTC memory for 11 years minimum.

Smart Freeze Point Protection will run the chiller at 36°F (2.2°C) leaving chilled water temperature eliminating nuisance trips on Low Water Temperature. The sophisticated program and sensors will monitor the chiller water and evaporator refrigerant liquid temperatures to prevent freeze up. Every programmable point has a pop-up screen with the allowable ranges, so that the chiller can not be programmed to operate outside of its design limits.

The capacity control logic provides stable operation at maximum efficiency at off design conditions by modulating the turbine speed, compressor pre-rotation vanes and hot gas by-pass valve.

When the power is applied to the chiller, the HOME screen is displayed. This screen displays a visual representation of the chiller and a collection of data detailing important operations and parameters. The primary values that need to be monitored and controlled are shown on this screen. The owner can be confident that YORK's OptiView control system for the YST is unequalled in its design, control features and protection systems. See "Equipment Specifications" for a more detailed description of OptiView features.

# Equipment Specifications

## GENERAL

The YORK YST **MaxE** Centrifugal Liquid Chillers are completely factory-packaged including the evaporator, refrigerant condenser, compressor, steam turbine, lubrication systems, power panel, control center, and all inter-connecting unit piping and wiring. The steam condenser package is shipped separately suitable for direct mounting onto the chiller or mounting along-side.

The initial charge of refrigerant and oil is supplied for each chiller. When the optional refrigerant condenser isolation valves are ordered, the unit may ship fully charged with refrigerant and oil. Actual shipping procedures will depend on a number of project-specific details.

The services of a YORK factory-trained, field service representative are incurred to supervise or perform the final leak testing, charging, the initial start-up, and concurrent operator instructions.

## COMPRESSOR

The compressor is a single-stage centrifugal type powered by a steam turbine. The casing is fully accessible with vertical circular joints and fabricated of close-grain cast iron. The complete operating assembly is removable from the compressor and scroll housing.

The rotor assembly consists of a heat-treated alloy steel drive shaft and impeller shaft with a high strength, cast aluminum alloy, fully shrouded impeller. The impeller is designed for balanced thrust and is dynamically balanced and overspeed tested for smooth, vibration free operation.

The insert-type journal and thrust bearings are fabricated of aluminum alloy and are precision bored and axially grooved. The specially engineered, single helical gears with crowned teeth are designed so that more than one tooth is in contact at all times to provide even distribution of compressor load and quiet operation. Gears are integrally assembled in the compressor rotor support and are film lubricated. Each gear is individually mounted in its own journal and thrust bearings to isolate it from impeller and turbine forces.

## CAPACITY CONTROL

During part load operation at off design conditions, the chiller capacity is reduced to maintain a constant leaving chilled liquid temperature by first decreasing the speed, then closing the compressor pre-rotation vanes (PRV). This provides capacity reduction from 100% to 15% of design for normal air conditioning applications. The speed is controlled by a pneumatically actuated governor valve which throttles the inlet steam flow to the turbine to

maintain the speed dictated by the capacity control logic. If the tower water temperatures must be held above 75°F for other chillers, the capacity control logic automatically limits the amount of speed reduction and PRV closure to maintain stable operation. The hot gas by-pass valve is then modulated to maintain a constant leaving chilled liquid temperature with loads down to 10% of design.

The vanes are actuated by an external, electric PRV actuator. Rugged, airfoil shaped, cast manganese bronze vanes are precisely positioned by solid vane linkages connected to the electric actuator.

## COMPRESSOR LUBRICATION SYSTEM

Lubrication oil is force-fed to all bearings, gears and rotating surfaces by a variable speed drive pump which operates prior to startup, continuously during operation and during coastdown. A gravity-fed oil reservoir is built into the top of the compressor to provide lubrication during coastdown in the event of a power failure.

An oil reservoir, separate from the compressor, contains the submersible oil pump, 2 HP pump motor and 3000 watt immersion-type oil heater. The oil heater is thermostatically controlled to remove refrigerant from the oil.

Oil is filtered by an externally mounted 1/2 micron replaceable cartridge oil filter equipped with service valves. Oil is cooled via a shell and tube, water cooled oil cooler sized to use refrigerant condenser water as the cooling medium. The oil side of the oil cooler is provided with service valves. Oil piping is completely factory-installed. The water side of the oil cooler is provided with service valves, inlet strainer and solenoid valve for automatic start/stop of cooling water flow. Water piping is factory installed with customer connections conveniently brought to the edge of the chiller package and clearly tagged for installation. An automatic oil return system recovers any oil that may have migrated to the evaporator. Oil temperature control is by an Amot, three way temperature control valve.

## STEAM TURBINE

The steam turbine is a high efficiency multistage design operating at a nominal 4500 rpm design maximum speed.

The turbine is packaged on a driveline base, completely factory piped. The driveline base has a mating flange on shaft end of the package that will bolt directly to the compressor D-flange face providing a rigid interface between turbine package and compressor. Complete turbine/compressor driveline is factory aligned prior to shipment. Turbine drive shaft is directly connected to the compressor shaft with a flexible disc coupling. Coupling is of an all metal construction with no wearing parts as-

# Equipment Specifications (continued)

---

suring long life and no lubrication requirements providing low maintenance.

The turbine casing is horizontally split designed to allow longitudinal thermal expansion without the affecting alignment or efficiency of the turbine. The shaft and wheels are alloy steel with the wheels shrunk and keyed to the shaft. The turbine blades are 403 grade stainless steel and the shaft is ground throughout with stainless steel sprayed in the carbon ring end gland contact area. Stainless steel nozzles are furnished throughout the turbine. Carbon ring end gland and diaphragm seals are furnished. Turbine end gland carbon ring seals (minimum five seals per end gland) are separated by partitions of stainless steel.

A stainless steel, inlet steam strainer with adequate size and mesh to minimize the pressure drop is supplied. Strainer is removable without breaking the steam piping connections.

Blanket insulation is furnished on the steam chest and barrel of the turbine for operator protection.

The turbine speed is controlled by a governor valve which is integrated with the chiller controls. The valve is of stainless steel with stainless steel seats and designed to control flow throughout the entire operating range of the turbine. The system employs an overspeed governor designed to close an independent high performance butterfly trip valve with a pneumatic actuator when the turbine speed exceeds 110 percent of the maximum continuous operating speed of the turbine. Activation of the independent trip valve causes the governor valve to also close. A micro switch is furnished on the trip linkage for the customer's use.

## TURBINE LUBRICATION SYSTEMS

Ring Oil Lubricated Turbines - Drive powers less than 1700Hp (1268 kW) only:

The bearings are steel backed, babbitt lined, split sleeve type. The design is such that the bottom half is removable with the shaft in place. The bearing housing has provisions for air purging of the housing shaft seals. The thrust bearing is an antifriction ball bearing, accessible and removable without lifting the top half of the turbine casing. Oil cooling is by water cooled bearing housings.

External, Pressurized Lube System Turbines:

The bearings are steel backed, babbitt lined, split sleeve type. The design is such that the bottom half is removable with the shaft in place. The bear-

ing housing has provisions for air purging of the housing shaft seals. The thrust bearing is a double acting, Kingsbury type. The lubrication system is integral to the turbine driveline base and completely factory piped. The lubrication system consists of a shaft driven main oil pump, motor driven auxiliary oil pump, water cooled shell and tube oil cooler, 25 micron full flow oil filter and separate oil reservoir with level gauge. Oil temperature control is by an Amot, three way temperature control valve.

## STEAM CONDENSER PACKAGE

A steam condenser is provided to condense exhaust steam at vacuum pressures to maintain efficient turbine operation. The steam condenser water circuit is piped in series with the refrigerant condenser, eliminating a separate cooling water circuit and is designed to minimize pressure drop for energy savings.

The steam condenser is furnished fully packaged. The package includes a single hotwell pump, a single liquid ring vacuum pump for air removal, atmospheric relief valve and level control system. The package is factory piped, wired and mounted on a common structural steel frame suitable for installation on the refrigerant condenser or floor mounting adjacent to the chiller system.

Condensate level is controlled by a level control system with two (2) pneumatic control valves - one for re-circulation and the other for removal of condensate. The liquid ring vacuum pump is capable of drawing the condenser down to operating pressure in approximately 10 minutes. Hotwell pump is single-stage, end suction suitable for hotwell service. Steam side is designed for 15 psig (100 kPa) and 30" Hg Vac (760 mmHg).

Atmospheric relief valve is a water seal type with external handwheel, sized in accordance with the Heat Exchange Institute Standards (HEI) for protection of the steam turbine exhaust, steam trunk and steam condenser.

All key control and monitoring parameters are integrated with the chiller control panel. In addition, auxiliary pressure gauges are located at the condenser steam inlet and condensate pump discharge piping, and temperature gauges are located at the steam inlet, cooling water inlet and outlet, and the hotwell.

To facilitate rigging, condenser is separable from the skid by unbolting. Piping is outfitted with unions at suitable break-points. Both condenser and skid are outfitted with lifting lugs for both vertical and horizontal lifting.



## HEAT EXCHANGERS

### Shells

Evaporator, refrigerant condenser and steam condenser shells are fabricated from rolled carbon steel plates with fusion welded seams. Carbon steel tube sheets, drilled and reamed to accommodate the tubes, are welded to the end of each shell. Intermediate tube supports are fabricated from carbon steel plates, drilled and reamed to eliminate sharp edges. The refrigerant side of each shell is designed, tested, and stamped in accordance with ASME Boiler and Pressure Vessel Code, Section VIII - Division I, or other pressure vessel code as appropriate. The steam side of the steam condenser is designed in accordance with the Heat Exchange Institute (HEI), an industry standard for steam condenser technology.

### Tubes

Refrigerant heat exchanger tubes are state-of-the-art, high-efficiency, externally and internally enhanced type to provide optimum performance. Tubes in both the evaporator and refrigerant condenser are 3/4" O.D. (19 mm) copper alloy and utilize the "skip-fin" design, providing a smooth internal and external surface at each intermediate tube support. This provides extra wall thickness (up to twice as thick) and non-work hardened copper at the support location, extending the life of the heat exchangers. Each tube is roller expanded into the tube sheets providing a leak-proof seal, and is individually replaceable. Steam condenser tubes are copper, providing economical and efficient heat transfer.

### Evaporator

The evaporator is a shell and tube, flooded type heat exchanger. A distributor trough provides uniform distribution of refrigerant over the entire shell length to yield optimum heat transfer. A suction baffle or aluminum mesh eliminators are located above the tube bundle to prevent liquid refrigerant carryover into the compressor. A 1-1/2" (38 mm) liquid level sight glass is conveniently located on the side of the shell to aid in determining proper refrigerant charge. The evaporator shell contains a dual refrigerant relief valve arrangement set at 180 psig (1241 kPa); or single-relief valve arrangement, if the chiller is supplied with the optional refrigerant isolation valves. A 3/4" (19 mm) flare male charging connection is provided.

### Refrigerant Condenser

The refrigerant condenser is a shell and tube type, with a discharge gas baffle to prevent direct high velocity impingement on the tubes. The baffle is also used to distribute the refrigerant gas flow properly for most efficient heat transfer. An integral sub-cooler is located at the bottom of the refrigerant condenser shell providing highly effective liquid refrigerant subcooling to provide the highest cycle

efficiency. The refrigerant condenser contains dual refrigerant relief valves set at 235 psig (1620 kPa).

### Steam Condenser

Steam condenser construction is of the shell and tube type of welded steel construction with 3/4" OD (19 mm) prime surface copper tubes, roller-expanded into tube sheets. An impingement plate located below the centrally located steam inlet redirects steam flow to protect the tubes from high velocity steam. Subcooling sections in the condenser cool non-condensibles sufficiently below the condensing temperature thereby reducing the vacuum pump capacity required. Water side is suitable for a maximum working pressure of 150 psig (1030 kPa). An atmospheric relief valve, sized per HEI to protect the condenser, is included. This relief valve is set to open at 1-2 psig (7-14 kPa) and will prevent pressure in the condenser shell from exceeding 10 psig (69 kPa). Seal water is required to maintain a liquid seal in the valve. An inlet and overflow connection is provided on the valve for this purpose.

### Water Boxes

The water boxes are fabricated from steel and are marine style (compact or marine available on evaporator). The standard design working pressure is 150 psig (1030 kPa) and the chiller boxes are tested at 225 psig (1550 kPa). Steam condenser boxes are tested at 215 psig (1480kPa). Integral steel water baffles are located and welded within the water box to provide the required pass arrangements. Stub-out water nozzle connections with Victaulic grooves are welded to the water boxes. These nozzle connections are suitable for Victaulic couplings, welding or flanges, and are capped for shipment. Plugged 3/4" NPTI (19 mm) drain and vent connections are provided in each water box.

## REFRIGERANT FLOW CONTROL

Refrigerant flow to the evaporator is controlled by the YORK variable orifice control system. Liquid refrigerant level is continuously monitored to provide optimum subcooler, refrigerant condenser and evaporator performance. The variable orifice electronically adjusts to all Real-World operating conditions, providing the most efficient and reliable operation of refrigerant flow control.

## POWER PANEL

All motor contactors and circuit protectors, the compressor oil pump variable speed drive and the control power transformer are contained in an enclosure installed adjacent to the OptiView control center. A main power disconnect switch is supplied which provides the termination points for customer's single point power supply wiring.

# Equipment Specifications (continued)

---

## OPTIVIEW CONTROL CENTER

### General

The chiller is controlled by a stand-alone microprocessor based control center. The chiller control panel provides control of entire system, including turbine and steam condenser operation and monitoring.

The control panel includes a 10.4" diagonal color liquid crystal display (LCD) surrounded by "soft" keys which are redefined based on the screen displayed at that time, mounted in the middle of a keypad interface and installed in a locked enclosure. The screen details all operations and parameters, using a graphical representation of the chiller and its major components. Panel text is in English only. Data can be displayed in either English or Metric units. Additional features are:

- Smart Freeze Point Protection capable of running the chiller at 36°F (2.2°C) leaving chilled water temperature eliminating nuisance trips on low water temperature. The sophisticated program and sensors monitor the chiller water and evaporator refrigerant liquid temperatures to prevent freeze-up.
- The panel displays countdown timer messages so the operator knows when functions are starting and stopping. Every programmable point has a pop-up screen with the allowable ranges, so that the chiller can not be programmed to operate outside of its design limits.
- Security access is built in to prevent unauthorized change of setpoints, to allow local or remote control of the chiller, and to allow manual operation of the pre-rotation vanes and oil pump. Access is through ID and password recognition, which is defined by three different levels of user competence: view, operator, and service.
- Trending data is available with the ability to customize points from once every second to once every hour. The panel will trend up to 6 different parameters from a list of over 140, without the need of an external monitoring system.
- The operating program is stored in non-volatile memory to eliminate reprogramming the chiller due to AC power failure or battery discharge. Programmed setpoints are retained in lithium battery-backed RTC memory for a minimum of 11 years with power removed from the system.
- Includes an RS-232 port to output all system operating data, shutdown/cycling message, and a record of the last 10 cycling or safety shutdowns to a field-supplied printer. Data logs to a printer at a set programmable interval. This data can be preprogrammed to print from 1 minute to 1 day.
- The text displayed within the system status and system details field is displayed as a color-coded mes-

sage to indicate severity: red for safety fault, orange for cycling faults, yellow for warnings, and green for normal messages.

The chiller control panel provides a multitude of diagnostic and operating data too numerous to cover completely in this guide. However, a general description of some of the data available and examples of the various screens provided follows:

Some highlights (not all inclusive) of the data available on the panel are as follows:

### System Operating Information

#### Evaporator

- Leaving and return chilled water temperature
- Refrigerant liquid temperature - evaporator
- Evaporator pressure
- Hot gas control status
- Chilled water flow

#### Refrigerant Condenser

- Entering and leaving refrigerant condenser water temperature
- Refrigerant liquid temperature - refrigerant condenser
- Refrigerant condenser pressure
- Subcooler refrigerant liquid level
- Subcooler refrigerant liquid level control status
- Refrigerant condenser water flow

#### Compressor

- Compressor discharge temperature
- Compressor oil temperature
- Compressor supply oil pressure
- Compressor thrust bearing proximity probe gap (J compressors only)
- Pre-rotation vanes (PRV) position

#### Steam Turbine

- Turbine shaft end bearing temperature
- Turbine governor end bearing temperature
- Turbine inlet steam temperature
- Turbine inlet steam pressure
- Turbine first stage steam pressure
- Turbine exhaust pressure
- Turbine speed
- Turbine governor control status

#### Steam Condenser

- Hotwell condensate level
- Hotwell level control status

**Safety shutdowns****(will prevent unit from starting or operating)**

- Evaporator - low pressure
- Evaporator - low temperature (Smart Freeze Point Protection)
- Evaporator - transducer or leaving liquid probe failure
- Evaporator - transducer or temperature sensor failure
- Refrigerant condenser - high pressure contacts open
- Refrigerant condenser - high pressure
- Refrigerant condenser - pressure transducer out-of-range
- Compressor discharge - high temperature
- Compressor discharge - low temperature
- Compressor oil -high temperature
- Compressor oil - low differential temperature
- Compressor oil - high differential pressure
- Compressor oil - sump pressure transducer out-of-range
- Compressor oil - differential pressure calibration
- Compressor oil - variable speed pump - pressure setpoint not achieved
- Compressor thrust bearing - proximity probe uncalibrated (J compressors only)
- Compressor thrust bearing - proximity probe clearance (J compressors only)
- Compressor thrust bearing - proximity probe out-of-range (J compressors only)
- Control panel - power failure
- Turbine governor end bearing high temperature
- Turbine shaft end bearing high temperature
- Turbine oil - low pressure
- Turbine oil - high temperature
- Turbine underspeed
- Turbine exhaust high pressure
- Standby hotwell pump fault (warning on failure of primary pump)
- Standby vacuum pump - no sealing water flow (warning on failure of primary system)
- Standby vacuum pump fault (warning on failure of primary pump)
- Hotwell condensate high level
- Hotwell condensate low level

**CODES AND STANDARDS**

- ASME Boiler and Pressure Vessel Code - Section VIII Division 1.
- Heat Exchange Institute (HEI), Industry Standard for Steam Condensers

- NEMA (SM23) Steam Turbines for Mechanical Drive Services
- Expansion Joint Manufacturers Assoc., Inc. (EJMA)
- ARI Standard 550/590
- ASHRAE 15 - Safety Code for Mechanical Refrigeration
- ASHRAE Guideline 3 - Reducing Emission of Halogenated Refrigerants in Refrigeration and Air-Conditioning Equipment and Systems
- N.E.C. - National Electrical Code
- OSHA - Occupational Safety and Health Act

**ISOLATION MOUNTING**

The unit is provided with four vibration isolation mounts consisting of 1" (25.4 mm) thick neoprene isolation pads for field mounting under the steel mounting plates located on the tube sheets.

**REFRIGERANT CONTAINMENT**

The refrigerant circuit has been designed as a factory-packaged system. As such, it has minimum joints from which refrigerant can leak. The entire assembly has been thoroughly leak tested at the factory prior to shipment. The YORK chiller includes service valves conveniently located to facilitate transfer of refrigerant to a remote refrigerant storage/recycling system. Optional refrigerant condenser isolation valves allow storage of the charge in the refrigerant condenser.

**PAINT**

Exterior surfaces are protected with one coat of Caribbean blue, durable alkyd-modified, vinyl enamel, machinery paint.

**SHIPMENT**

Protective covering is furnished on the control center. Water nozzles are capped with fitted plastic enclosures. Entire unit is protected with industrial-grade, reinforced shrink-wrapped covering.

# Accessories and Modifications

---

## FLOOR MOUNTED STEAM CONDENSER

As an alternative to the standard packaged location, the steam condenser package can be ordered for floor mounting adjacent to the chiller package. Prefabricated piping kits for the steam trunk, water piping and wiring between chiller package and steam condenser are not included with a floor mounted arrangement. These interconnecting components must be designed, supplied and installed by customer.

Note: Interconnecting components may be ordered through the factory via a special quote upon request (site arrangement details will be required at time of request for quote).

## AUTO-START CONTROL FEATURES

When this option is ordered, the chiller is provided with all components and programming for the OptiView micropanel to automatically control the start-up and shutdown of the system. All solenoids and automated components necessary for full automation are provided. Some parts will ship loose for installation at job site. An automatic pressure powered pump is also provided for draining condensate from the steam turbine casing during operation.

## DUAL PUMPS FOR STEAM CONDENSER

### PACKAGE

Factory installed secondary (100% standby duty) condensate and vacuum pumps, including all interconnecting piping is available. Automatic switchover to a standby pump in the event of a primary pump failure is included in this option.

## STEAM TURBINE CASING DRAIN OPTIONS

The steam turbine casing must be provided with a means of draining during operation (while under vacuum). Factory options available for this function are:

- Automatic pressure powered pump
- Manual condensate drain tank (by special quote)
- Automatic condensate drain tank (by special quote)

Casing drain equipment is shipped loose for installation at job site.

## FACTORY INSULATION

Factory-applied thermal insulation of the flexible, closed-cell plastic type, 3/4" (19 mm) thick is attached with vapor-proof cement to the evaporator shell, flow chamber, tube sheets, suction connection, and (as necessary) to the auxiliary tubing. Not included is the insulation of compact water boxes and nozzles. This insulation will

normally prevent condensation in environments with relative humidities up to 75% and dry bulb temperatures ranging from 50° to 90°F (10° to 32°C). 1-1/2" (38 mm) thick insulation is also available for relative humidities up to 90% and dry bulb temperatures ranging from 50° to 90°F (10° to 32°C).

The turbine steam chest is insulated with a custom fitted, fiberglass insulating blanket for protection of personnel.

## WATER FLANGES

150 psig (1030 kPa) ANSI raised-face flanges for refrigerant condenser, evaporator and steam condenser water connections, are factory-welded to water nozzles. Companion flanges, bolts, nuts and gaskets are not included.

## MARINE WATER BOXES

Marine water boxes allow service access for cleaning of the heat exchanger tubes without the need to break the water piping. Bolted-on covers are arranged for convenient access. Victaulic nozzle connections are standard; flanges are optional. Marine water boxes are available for the evaporator (limited arrangements only).

*Note: Marine water boxes are standard scope of supply on the refrigerant and steam condensers.*

## KNOCK-DOWN SHIPMENT

The chiller can be shipped knocked down into major sub-assemblies (evaporator, refrigerant condenser, driveline, etc.) as required to rig into tight spaces. This is particularly convenient for existing buildings where equipment room access does not allow rigging a factory-packaged chiller.

*NOTE: Vertical rigging of components not allowed unless special design is ordered by special quote (SQ).*

## REFRIGERANT ISOLATION VALVES

Optional factory-installed isolation valves in the compressor discharge line and refrigerant liquid line are available. This allows isolation and storage of the refrigerant charge in the chiller refrigerant condenser during servicing, eliminating time-consuming transfers to remote storage vessels. Both valves are positive shut-off, assuring integrity of the storage system.

## 300 PSIG WATERSIDE DESIGN PRESSURE

Applications with greater than 150 psig (1030 kPa) water pressure can be accommodated by special quote upon

---

request. Special design required for all heat exchanger water boxes and turbine/compressor cooling water circuits.

### **BAS NETWORK INTERFACE**

A communication interface permitting complete exchange of chiller data with any BAS System is available with optional ISN MicroGateway. The Micro-Gateway also allows a BAS System to issue commands to the chiller to control its operation. All control data points are accessible to the BAS System. For full list of points, contact a York Representative.

### **REFRIGERANT STORAGE / RECYCLING SYSTEM**

A refrigerant storage/recycling system is a self-contained package consisting of a refrigerant compressor with oil separator, storage receiver, water-cooled condenser, filter drier and necessary valves and hoses to remove, replace and distill refrigerant. All necessary controls and safety devices are a permanent part of the system. Typically not required if unit isolation valves are provided.

# Application Data

---

The following discussion is a user's guide in the application and installation of YST **MaxE** chillers to ensure the reliable, trouble-free life for which this equipment was designed. While this guide is directed towards normal, water-chilling applications, the YORK sales representative can provide complete recommendations on other types of applications.

## LOCATION

YST **MaxE** chillers are virtually vibration free and may generally be located at any level in a building where the construction will support the total system operating weight.

The unit site must be a floor, mounting pad or foundation which is level within 1/4" (6 mm) and capable of supporting the operating weight of the unit.

Sufficient clearance to permit normal service and maintenance work should be provided all around and above the unit. Additional space should be provided at one end of the unit to permit cleaning of evaporator, refrigerant condenser and steam condenser tubes, as required. A doorway or other properly located opening may be used.

The chiller is designed to be installed in an indoor location where temperatures range from 40°F to 104°F (4.4°C to 40°C).

## WATER piping

**Flow Rate** - For normal water chilling duty, evaporator and refrigerant condenser flow rates are permitted at water velocity levels in the heat exchangers tubes of between 3 ft/sec and 12 ft/sec (0.9 m/s and 3.7 m/s). Variable flow applications are possible, however, chiller selections must be made using a water velocity within the range noted above. Variable flow in the refrigerant condenser is not recommended, as it generally raises the energy consumption of the system by keeping the refrigerant condenser pressure high in the chiller. Additionally, the rate of fouling in the refrigerant condenser will increase at lower water velocities associated with variable flow, raising system maintenance costs. Cooling towers typically have narrow ranges of operation with respect to flow rates and will be more effective with full design flow. Ref. Table 1 for flow limits.

**Temperature Ranges** - For normal water chilling duty, leaving chilled water temperatures may be selected between 38°F (3.3°C) [36°F (2.2°C) with Smart Freeze enabled] and 70°F (21°C) for water temperature ranges between 3°F and 30°F (1.7°C and 16.7°C).

**Water Quality** – The practical and economical application of liquid chillers requires that the quality of the water

supply for the condensers and evaporator be analyzed by a water treatment specialist. Water quality may affect the performance of any chiller through corrosion, deposition of heat-resistant scale, sedimentation or organic growth. These will degrade chiller performance and increase operating and maintenance costs. Normally, performance may be maintained by corrective water treatment and periodic cleaning of tubes. If water conditions exist which cannot be corrected by proper water treatment, it may be necessary to provide a larger allowance for fouling, and/or to specify special materials of construction.

**General Piping** – All chilled water and condenser water piping should be designed and installed in accordance with accepted piping practice. Chilled water and condenser water pumps should be located to discharge through the chiller to assure positive pressure and flow through the unit. Piping should include offsets to provide flexibility and should be arranged to prevent drainage of water from the evaporator and condenser when the pumps are shut off. Piping should be adequately supported and braced independently of the chiller to avoid the imposition of strain on chiller components. Hangers must allow for alignment of the pipe. Isolators in the piping and in the hangers are highly desirable in achieving sound and vibration control.

**Convenience Considerations** – To facilitate the performance of routine maintenance work, some or all of the following steps may be taken by the purchaser: Heat exchanger water boxes are equipped with plugged vent and drain connections. If desired, vent and drain valves may be installed with or without piping to an open drain. Pressure gauges with stop cocks and stop valves may be installed in the inlets and outlets of the condensers and chilled water line as close as possible to the chiller. An overhead monorail or beam may be used to facilitate servicing.

**Connections** – The standard chiller is designed for 150 psig (1030 kPa) design working pressure in both the chilled water and condenser water circuits. The connections (water nozzles) to these circuits are furnished with grooves for Victaulic couplings. Piping should be arranged for ease of disassembly at the unit for tube cleaning. All water piping should be thoroughly cleaned of all dirt and debris before final connections are made to the chiller.

**Chilled Water** – A water strainer of maximum 1/8" (3 mm) perforated holes must be field-installed in the chilled water inlet line as close as possible to the chiller. If located close enough to the chiller, the chilled water pump may be protected by the same strainer. The loss or severe reduction of water flow due to tube blockage could seriously impair the chiller performance or even result in tube freeze-up.

**Condenser Water** – The chiller is engineered for maximum efficiency at both design and part load operation by taking advantage of the colder cooling tower water temperatures which naturally occur during the winter months. Appreciable power savings are realized from these reduced heads.

The minimum entering condenser water temperature is provided by the following equation:

$$\text{In } ^\circ\text{F: minCondWT} = \text{LChilledWT} - \text{CondRange} \times (\text{PCT-Load}/100) + 5 + 12 \times (\text{PctLoad}/100)$$

$$\text{In } ^\circ\text{C: minCondWT} = \text{LChilledWT} - \text{CondRange} \times (\text{PCT-Load}/100) + (5 + 12 \times (\text{PctLoad}/100))/1.8$$

where:

minCondWT = entering condenser water temperature

LChilledWT = leaving chilled water temperature

CondRange = condenser water temperature range at design.

PCTLoad = chiller load as % design

At initial startup, entering condensing water temperature may be as much as 25°F (14°C) colder than the standby chilled water temperature as long as it is above the minimum entering condenser water temperature allowed.

A water strainer of maximum 1/8" (3 mm) perforated holes is recommended to be field-installed in the refrigerant condenser water inlet line as close as possible to the chiller. If located close enough to the chiller, the condenser water pump may be protected by the same strainer. The loss or severe reduction of water flow due to tube blockage could seriously impair the chiller performance.

## STEAM AND CONDENSATE PIPING

Turbine supply steam and condensate piping connections to the chiller are to be supplied and installed by the site piping contractor. In addition, the turbine exhaust to the steam condenser shall be installed by the piping contractor, however, the design and supply of components may be supplied by YORK depending on the options chosen. Piping should be adequately supported and braced independently of the chillers. Hangers must allow for piping alignment at the operation temperature. Piping contractor is responsible for the fit and form of the turbine steam piping. The piping must be installed with the flanges and bolt holes properly aligned. The bolts should be able to be inserted without any difficulty and no force should be applied to allow the bolts to be inserted or flanges aligned. When the flange bolts are tightened, they must not impose

any force or moment on the turbine flanges. Contact your local YORK office for any additional information.

## RELIEF PIPING

### Refrigerant Relief

Each chiller is equipped with dual pressure relief valves on the refrigerant condenser and two dual relief valves on the evaporator, or two single relief valves on the evaporator if the optional refrigerant isolation valves are ordered. The dual relief valves on the refrigerant condenser are redundant and allow changing of either valve while the unit is fully charged. The purpose of the relief valves is to quickly relieve excess pressure of the refrigerant charge to the atmosphere, as a safety precaution in the event of an emergency such as fire. They are set to relieve at an internal pressure as noted on the pressure vessel data plate, and are provided in accordance with ASHRAE 15 safety code and ASME or applicable pressure vessel code.

Sized to the requirements of applicable codes, a vent line must run from the relief device to the outside of the building. This refrigerant relief piping must include a cleanable, vertical-leg dirt trap to catch vent-stack condensation. Vent piping must be arranged to avoid imposing a strain on the relief connection and should include one flexible connection.

### Steam Relief

Each steam condenser is equipped with an atmospheric relief valve, sized to relieve all the steam which can be admitted to a turbine under maximum possible full throttle conditions. The atmospheric relief valve is designed/selected per HEI standards for steam condensers and provides protection for the steam turbine exhaust and exhaust trunk, as well as the steam condenser shell. The discharge of the atmospheric relief valve should be piped to direct a large volumetric flow of hot steam to a safe area, away from all personnel.

## SOUND AND VIBRATION CONSIDERATIONS

A YST **MaxE** chiller is not a source of objectionable sound and vibration in normal air conditioning applications. Neoprene isolation mounts are furnished as standard with each unit.

YST **MaxE** chiller sound pressure level ratings will be furnished on request.

Control of sound and vibration transmission must be taken into account in the equipment room construction as well as in the selection and installation of the equipment.

# Application Data (continued)

## THERMAL INSULATION

No appreciable operating economy can be achieved by thermally insulating the chiller. However, the chiller's cold surfaces should be insulated with a vapor barrier insulation sufficient to prevent condensation. A chiller can be factory-insulated with 3/4" (19 mm) or 1-1/2" (38 mm) thick insulation, as an option. This insulation will normally prevent condensation in environments with dry bulb temperatures of 50°F to 90°F (10°C to 32°C) and relative humidities up to 75% [3/4" (19 mm) thickness] or 90% [1-1/2" (38 mm) thickness]. The insulation is painted and the surface is flexible and reasonably resistant to wear. It is intended for a chiller installed indoors and, therefore, no protective covering of the insulation is usually required. If insulation is applied to the water boxes at the job site, it must be removable to permit access to the tubes for routine maintenance. The turbine steam chest is factory insulated with a custom fitted, fiberglass insulating blanket for protection of personnel. The blanket is removable for maintenance access to the turbine.

## VENTILATION

The ASHRAE Standard 15 Safety Code for Mechanical Refrigeration requires that all machinery rooms be vented to the outdoors utilizing mechanical ventilation by one or more power-driven fans. This standard, plus National Fire Protection Association Standard 90A, state, local and any other related codes should be reviewed for specific requirements. Since the YST **MaxE** chiller uses steam, ventilation should allow for the removal of heat radiated from the steam turbine.

In addition, the ASHRAE Standard 15 requires a refrigerant vapor detector to be employed for all refrigerants. It is to be located in an area where refrigerant from a leak would be likely to concentrate. An alarm is to be activated and the mechanical ventilation started at a value no greater than the TLV (Threshold Limit Value) of the refrigerant.

## CUSTOMER CONNECTIONS/INTERFACES (see product drawings for connection sizes)

### Water/Drains

- Refrigerant condenser inlet/outlet\*\*
- Evaporator inlet/outlet
- Turbine/Compressor cooling water manifold inlet/outlet
- Steam condenser inlet\*\*/outlet
- Steam condenser vacuum pump seal water: 3.5 gpm (0.2 L/s) @ approx. 60°F (15.6 °C)
- Steam condenser vacuum pump discharge separator vent and drain
- Steam condenser relief valve seal water: trickle flow
- Steam condenser relief valve seal water drain

- Steam turbine casing drain
- Steam turbine gland leak off drain
- Steam turbine steam ring drain
- Steam condenser condensate overboard valve: [note: approx. 20 psig (138 kPa) discharge pressure available at outlet of overboard valve. If downstream pressure requirements exceed this, a custom condensate pump selection is required.]
- Steam condenser hotwell level system drain
- Water box vents and drains - evaporator, refrigerant condenser and steam condenser

*\*\*York provided pre-fabricated piping for these connections*

### Steam/Vents

- Steam turbine steam inlet
- Steam turbine steam exhaust\*\*
- Steam condenser steam inlet\*\*
- Steam condenser relief valve vent
- Steam turbine gland sealing steam: 150 psig (1030 kPa) max. steam supply
- Steam turbine gland seal relief valve

*\*\*York provided pre-fabricated piping for these connections*

### Refrigerant Connections

- Refrigerant drain/charging connection
- Refrigerant transfer/service connections
- Refrigerant condenser relief valves(s)
- Evaporator relief valve(s)

### Air (Instrument Quality Air Source - ISA S7.3)

- Steam turbine governor air supply and bearing seal air purge: 80-150 psig (552 - 1030 kPa), approx. 13 SCFM (22 sm<sup>3</sup>/h).
- Steam condenser level control system: 20-150 psig (138 - 1030 kPa), approx. 0.5 SCFM (0.9 sm<sup>3</sup>/h).

### Power

- 460V single point power connection, approximately 28.6 KVA (KD turbine) or 24.2 KVA (KG turbine).

### Required Auxiliary Components (customer supplied)

- Steam inlet strainer: Full flow strainer with fine [3/64" (1.2 mm) perforations], stainless steel mesh, suitable for steam service.
- Steam inlet moisture separator: Steam supply to turbine must be dry & saturated for optimum efficiency.
- Steam inlet throttling valve: Manual globe valve for inlet steam isolation and throttling (during start up). Note: This valve is York supplied when the system auto-start option is ordered.



**TABLE 1 – WATER FLOW RATE LIMITS (GPM) — BASED UPON STANDARD TUBES @ DESIGN FULL LOAD CONDITIONS**

Model	Evaporator						Model	Condenser					
	1 Pass		2 Pass		3 Pass			1 Pass		2 Pass		3 Pass	
	Min	Max	Min	Max	Min	Max		Min	Max	Min	Max	Min	Max
HF	1981	7921	991	3336	660	2224	GB	2826	10179	1413	4277	–	–
HH	2330	9318	1165	3863	777	2590	GD	3313	11935	1657	4936	–	–
JF	2738	10949	1369	4552	913	3069	HB	3851	13873	1926	5823	–	–
JG	2961	11841	1481	4885	987	3305	HD	4176	15044	2088	6264	–	–
JH	3182	12721	1591	5198	1061	3529	JB	4782	17226	2391	7059	–	–
TF	2738	10949	1369	4552	913	2880	JD	5313	19140	2657	7722	–	–
TG	2961	11841	1481	4591	987	3101	TB	4782	17226	2391	8614	–	–
TH	3182	12721	1591	4896	1061	3318	TD	5313	19140	2657	7267	–	–
VF	3507	14023	1754	5480	1169	3634	VB	6075	21883	3037	8417	–	–
VH	3836	15338	1918	5947	1279	3947	VD	6792	24467	3396	9280	–	–
–	–	–	–	–	–	–	–	–	–	–	–	–	–
WF	4382	17520	2191	6851	1461	4524	–	–	–	–	–	–	–
WH	5113	20442	2556	7886	1704	5214	–	–	–	–	–	–	–

**TABLE 1A – WATER FLOW RATE LIMITS (L/S) — BASED UPON STANDARD TUBES @ DESIGN FULL LOAD CONDITIONS**

Model	Evaporator						Model	Condenser					
	1 Pass		2 Pass		3 Pass			1 Pass		2 Pass		3 Pass	
	Min	Max	Min	Max	Min	Max		Min	Max	Min	Max	Min	Max
HF	125	500	62	210	42	140	GB	178	642	89	270	–	–
HH	147	588	74	244	49	163	GD	209	753	105	311	–	–
JF	173	691	86	287	58	194	HB	243	875	121	367	–	–
JG	187	747	93	308	62	209	HD	263	949	132	395	–	–
JH	201	803	100	328	67	223	JB	302	1087	151	445	–	–
TF	173	691	86	270	58	182	JD	335	1208	168	487	–	–
TG	187	747	93	290	62	196	TB	302	1087	151	543	–	–
TH	201	803	100	309	67	249	TD	335	1208	168	458	–	–
VF	221	885	111	346	74	229	VB	383	1381	192	531	–	–
VH	242	988	121	375	81	249	VD	429	1544	214	585	–	–
							–	–	–	–	–	–	–
WF	276	1105	138	432	92	285	–	–	–	–	–	–	–
WF	323	1290	161	498	108	329	–	–	–	–	–	–	–



# Application Data (continued)

**TABLE 2 – AVAILABLE COMPRESSOR/SHELL/TURBINE/STEAM CONDENSER MODELS**

COMPRESSOR CODE	EVAPORATOR CODE	CONDENSER CODE	TURBINE MODEL	STEAM CONDENSER MODEL
J1	HF, HH	GB, GD	K2G51000090	29168A
			K2G51000125	29168B
			K2G71000090	29168C
			K2G71000125	29168D
J2	HF, HH	GB, GD HB, HD	KG81250090	31168B
			K2G71250125	31168C
				31168D
J3	JF, JG, JH	JB, JD	KG81620090	35168B
			K2G71620125	35168C
			KD71620090	35168D
			KD71620125	
J4	TF, TG, TH	TB, TD	KD71620090 KD71620125 KD71750090 KD71750125	33192B
	VF, VH	VB, VD		33192C
	WF, WH	VB, VD		33192D

# Dimensions (Ft. - In.) – Top Mtd. Unit

## J COMPRESSOR UNITS

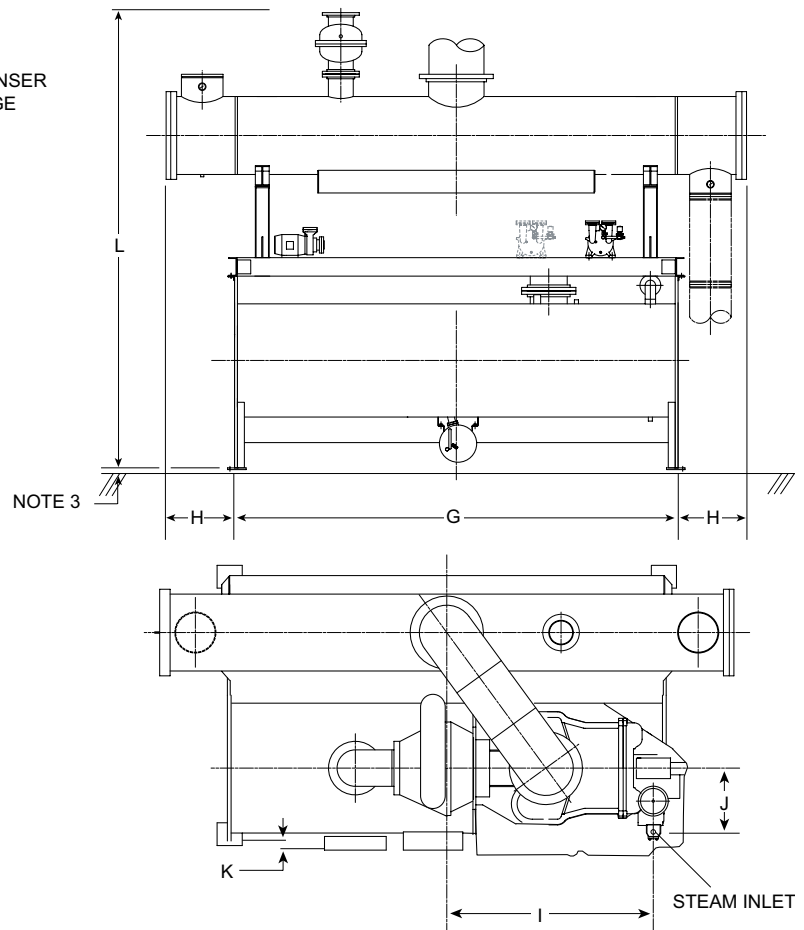
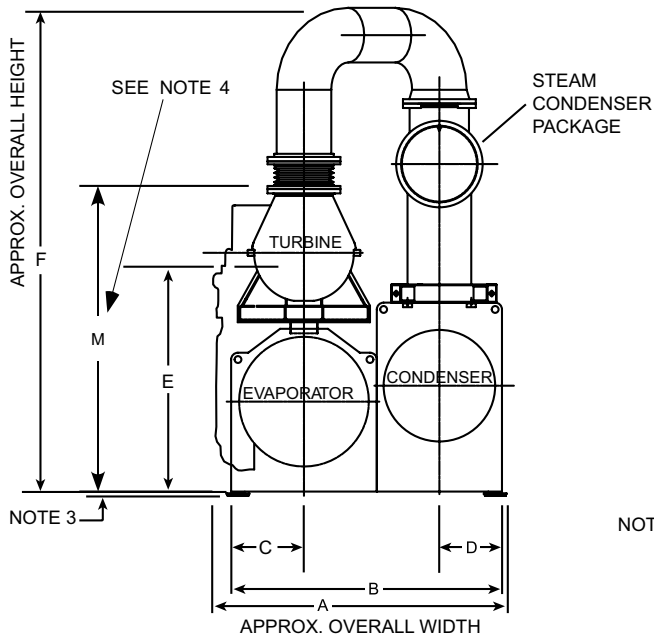

J1 COMPRESSOR (H-G SHELLS) KG STEAM TURBINE / 29168 STEAM CONDENSER	
DIMENSION CODE	FT-INCHES
A	8'-11 1/4"
B	7'-10 1/2"
C	2'-2 1/4"
D	1'-9"
E W/4" STEAM INLET	6'-11 3/4"
E W/6" STEAM INLET	6'-10 1/2"
F	15'-9"
G	14'-0"
I	6'-8 1/4"
J W/4" STEAM INLET	1'-9 3/16"
J W/6" STEAM INLET	2'-2 3/16"
K	0'-3 3/4"
L	14'-7"
M	10"-0"

J2 COMPRESSOR KG STEAM TURBINE / 31168 STEAM CONDENSER		
SHELL CODE	H-G	H-H
DIMENSION CODE	FT-INCHES	FT-INCHES
A	8'-11 1/4"	9'-2"
B	7'-10 1/2"	8'-2 1/2"
C	2'-2 1/4"	2'-2 1/4"
D	1'-9"	1'-11"
E W/4" STEAM INLET	6'-11 3/4"	6'-14 3/4"
E W/6" STEAM INLET	6'-10 1/2"	6'-13 1/2"
F	15'-11"	16'-3"
G	14'-0"	14'-0"
I	6'-8 1/4"	6'-8 3/8"
J W/4" STEAM INLET	1'-9 3/16"	1'-9 3/16"
J W/6" STEAM INLET	2'-2 3/16"	2'-2 3/16"
K	0'-3 3/4"	0'-3 3/4"
L	14'-8 15/16"	15'-0 15/16"
M	10'-0"	10'-3"

**NOTES:**

1. All dimensions are approximate. Certified dimensions are available on request.
2. Water nozzles can be located on either end of unit. Add 1/2" to nozzle length for flanges connections.
3. Add 1-3/4" for neoprene pads or 3/4" if neoprene pads are not supplied.
4. Approx. overall shipping height to top of compressor Casing. Steam condenser ships separately to job site.

# Dimensions (Ft. - In.) – Top Mtd. Unit - Cont.

## TOP MOUNTED CHILLER FOOTPRINT

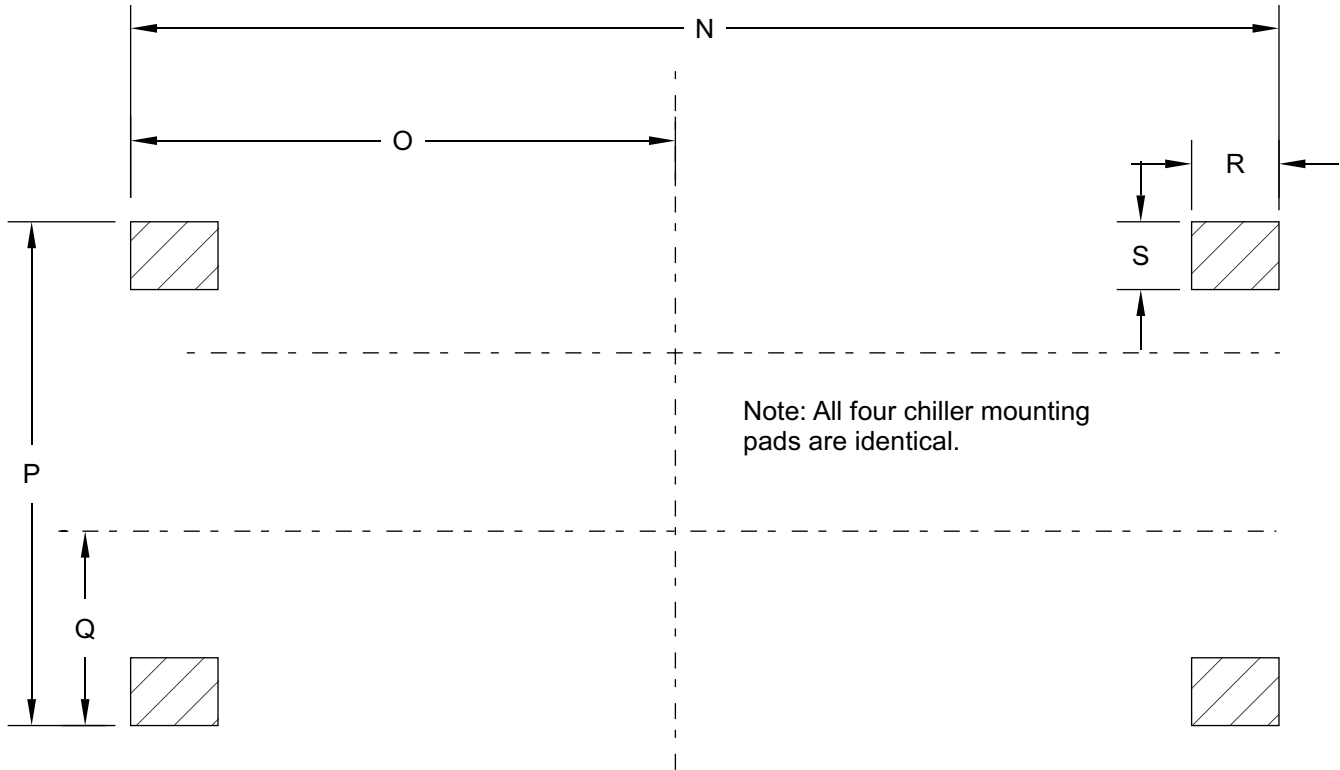

MODEL	N	O	P	Q	R	S
H-G-J1	14'-8"	7'-4"	8'-1-1/2"	2'-3-3/4"	10"	9"
H-G-J2	14'-8"	7'-4"	8'-1-1/2"	2'-3-3/4"	10"	9"
H-H-J2	14'-8"	7'-4"	8'-5-1/2"	2'-3-3/4"	10"	9"
J-J-J3	14'-8"	7'-4"	9'-4"	2'-7"	10"	9"
T-T-J4	16'-8"	8'-4"	9'-4"	2'-7"	10"	9"
V-V-J4	16'-8"	8'-4"	9'-9"	2'-7"	10"	9"
W-V-J4	16'-9"	8'-4-1/2"	10'-3"	2'-10"	10"	9"

**J3 COMPRESSOR (J-J SHELLS)****35168 STEAM CONDENSER**

DIMENSION CODE	KG STEAM TURBINE	KD STEAM TURBINE
	FT-INCHES	FT-INCHES
A	10'-0"	10'-2"
B	9'-1"	9'-1"
C	2'-5-1/2"	2'-5-1/2"
D	2'-1"	2'-1"
E W/4" STEAM INLET	7'-8-3/4"	7'-7-1/2"
E W/6" STEAM INLET	7'-7-1/2"	7'-7-1/2"
F	17'-7"	17'-7"
G	14'-0"	14'-0"
I	6'-7-1/2"	TBD
J W/4" STEAM INLET	1'-9-3/16"	2'-5-1/4"
J W/6" STEAM INLET	2'-2-3/16"	2'-5-7/16"
K	0'-4-1/2"	0'-4-1/2"
L	15'-10"	15'-10"
M	11'-0"	11'-0"

**J4 COMPRESSOR****KD STEAM TURBINE / 33192 STEAM CONDENSER**

SHELL CODE	T-T	V-V	W-V
DIMENSION CODE	FT-INCHES	FT-INCHES	FT-INCHES
A	10'-2"	10'-5"	10'-9"
B	9'-1"	9'-6"	9'-11"
C	2'-5-1/2"	2'-5-1/2"	2'-8"
D	2'-1"	2'-3-1/2"	2'-3-1/2"
E W/4" STEAM INLET	7'-9-1/2"	7'-11-1/2"	8'-2"
E W/6" STEAM INLET	7'-9-1/2"	7'-11-1/2"	8'-2"
F	17'-4"	17'-9"	17'-9"
G	16'-0"	16'-0"	16'-0"
I	TBD	TBD	TBD
J W/4" STEAM INLET	2'-5-1/4"	2'-5-1/4"	2'-5-1/4"
J W/6" STEAM INLET	2'-5-7/16"	2'-5-7/16"	2'-5-7/16"
K	0'-4-1/2"	0'-4-1/2"	0'-4"
L	16'-0-1/8"	16'-5-1/8"	16'-5-1/8"
M	11'-2"	11'-4"	11'-6"

**DIMENSION "H" FOR ALL J COMPRESSOR MODELS****STEAM CONDENSER MODEL 29168**

SHELL CODE	1 PASS REFRIG. COND. FT-IN.	2 PASS REFRIG. COND. FT-IN.
H-G	26-15/16"	25-5/16"

**STEAM CONDENSER MODEL 31168**

SHELL CODE	1 PASS REFRIG. COND. FT-IN.	2 PASS REFRIG. COND. FT-IN.
H-G	27-5/16"	25-11/16"
H-H	31-11/16"	27-13/16"

**STEAM CONDENSER MODEL 35168**

SHELL CODE	1 PASS REFRIG. COND. FT-IN.	2 PASS REFRIG. COND. FT-IN.
J-J	32-3/16"	28-5/16"

**STEAM CONDENSER MODEL 33192**

SHELL CODE	1 PASS REFRIG. COND. FT-IN.	2 PASS REFRIG. COND. FT-IN.
T-T	31-15/16"	28-1/16"
V-V	31-15/16"	29-5/8"
W-V	31-15/16"	29-5/8"

# Dimensions (Eng.) – Evap. Compact Water Boxes

## EVAPORATORS – COMPACT WATER BOXES – J COMPRESSOR UNITS

1-PASS

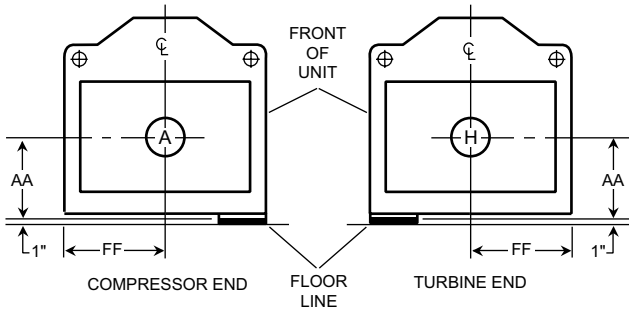

NOZZLE ARRANGEMENTS		
NO. OF PASSES	EVAPORATOR	
	IN	OUT
1	A	H
	H	A

2-PASS

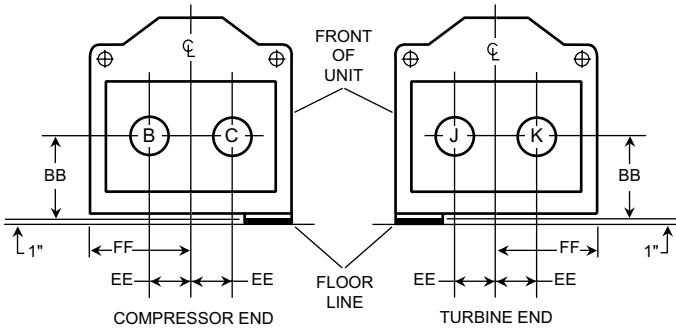

NOZZLE ARRANGEMENTS		
NO. OF PASSES	EVAPORATOR	
	IN	OUT
2	B	C
	C	B
	J	K
	K	J

3-PASS

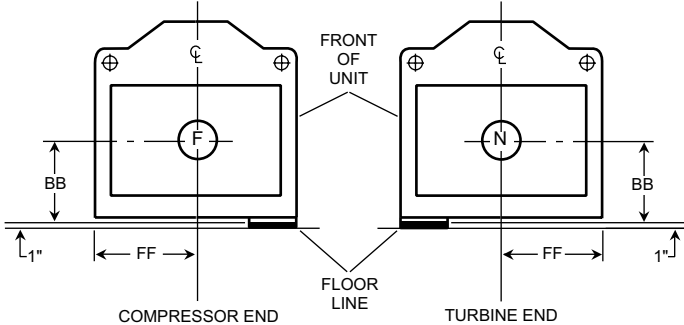

NOZZLE ARRANGEMENTS		
NO. OF PASSES	EVAPORATOR	
	IN	OUT
3	F	N
	N	F

EVAP. SHELL CODE	NOZZLE PIPE SIZE			EVAPORATOR NOZZLE DIMENSIONS							
	NO. OF PASSES			1-PASS		2-PASS			3-PASS		
	1	2	3	AA <sup>2</sup>	FF	BB <sup>2</sup>	EE	FF	BB <sup>2</sup>	FF	
HF	16"	12"	10"	2'-0-3/4"	2'-2-1/4"	2'-0-3/4"	11"	2'-2-1/4"	2'-0-3/4"	2'-2-1/4"	
HH	16"	12"	10"	2'-1-1/2"	2'-2-1/4"	2'-1-1/2"	11"	2'-2-1/4"	2'-1-1/2"	2'-2-1/4"	
J	18"	14"	12"	2'-1-3/4"	2'-5-1/2"	2'-1-3/4"	11"	2'-5-1/2"	2'-1-3/4"	2'-5-1/2"	
T	18"	14"	12"	2'-1-3/4"	2'-5-1/2"	2'-1-3/4"	11"	2'-5-1/2"	2'-1-3/4"	2'-5-1/2"	
V	20"	16"	12"	2'-5-1/4"	2'-5-1/2"	2'-5-1/4"	1'-1"	2'-5-1/2"	2'-5-1/4"	2'-5-1/2"	
W	20"	18"	14"	2'-7-1/4"	2'-8"	2'-7-1/4"	1'-3"	2'-8"	2'-7-1/4"	2'-8"	

### NOTES:

- Standard water nozzles are furnished as welding stub-outs with Victaulic grooves, allowing the option of welding, flanges, or use of Victaulic couplings. Factory-installed, class 150 (ANSI B16.5, round slip-on, forged carbon steel with 1/16" raised face), water flanged nozzles are optional (add 1/2" to nozzle length). Companion flanges, nuts, bolts, and gaskets are not furnished.
- Add 1" if neoprene pads are supplied.
- One-, two- and three-pass nozzle arrangements are available only in pairs shown and for all shell codes. Any pair of evaporator nozzles may be used in combination with any pair of condenser nozzles.
- Connected piping should allow for removal of compact water boxes for tube access and cleaning.



# Dimensions (Eng.) – Evap. Marine Water Boxes

## EVAPORATORS – MARINE WATER BOXES – J COMPRESSOR UNITS

COMPR. CODE	EVAP-COND SHELL CODE	G	H
J1, J2	H-G	1'-2 3/4"	1'-11 3/4"
	H-H	1'-2 3/4"	1'-11 3/4"
	J-J	1'-2 3/4"	1'-11 3/4"
J3, J4	T-T	1'-2 3/4"	1'-11 3/4"
	V-V	1'-2 3/4"	1'-11 3/4"
	W-V	1'-4 1/2"	2'-0 3/4"

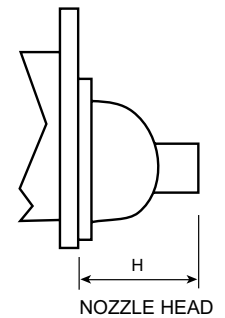
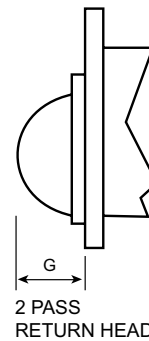

LD08639

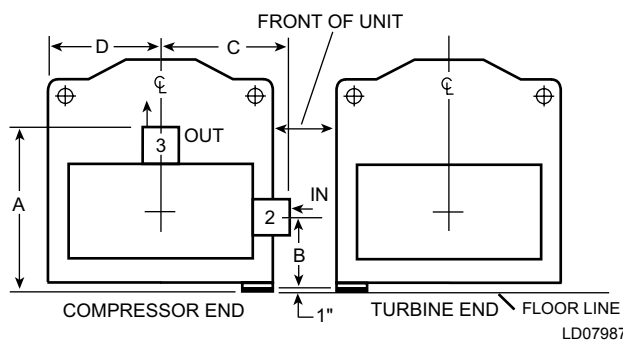

**2-PASS**

EVAP. SHELL CODE	EVAPORATOR NOZZLE DIMENSIONS			
	2-PASS			
	A <sup>5</sup>	B <sup>5</sup>	C	D
HF	4'-5-1/4"	2'-2-3/4"	2'-7-1/4"	2'-2-1/4"
HH	4'-6"	1'-8-1/4"	2'-7-1/4"	2'-2-1/4"
J	3'-11-3/4"	1'-9-3/4"	2'-10-1/4"	2'-5-1/2"
T	3'-11-3/4"	1'-9-3/4"	2'-10-1/4"	2'-5-1/2"
V	4'-3-1/4"	2'-1-1/2"	2'-10-1/4"	2'-5-1/2"
W	4'-6-1/2"	2'-3-1/2"	3'-2"	2'-6"

EVAPORATOR 2-PASS	
IN	OUT
2	3

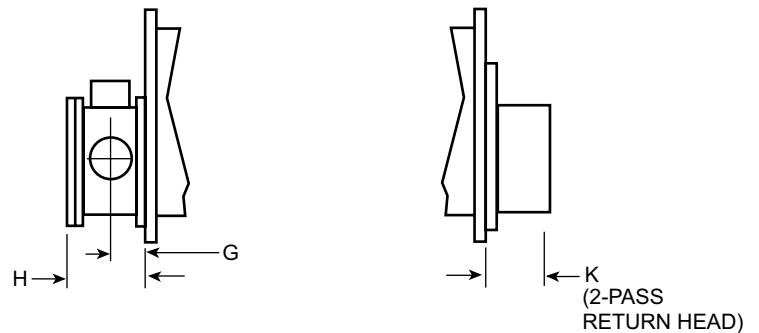

EVAPORATOR SHELL CODE	NOZZLE PIPE SIZE NO. OF PASSES
	2
H	12"
J	14"
T	14"
V	16"
W	18"

EVAPORATOR SHELL CODE	EVAPORATOR NOZZLE DIMENSIONS (2-PASS)		
	G	H	K
H	11-3/8"	2'-0-3/4"	1'-2-3/4"
J	1'-0-3/8"	2'-2-3/4"	1'-2-3/4"
T	1'-0-3/8"	2'-2-3/4"	1'-2-3/4"
V	1'-2"	2'-6"	1'-2-3/4"
W	1'-3"	2'-6"	1'-4-1/2"

**NOTES:**

- All dimensions are approximate. Certified dimensions are available upon request.
- Standard water nozzles are Schedule 40 pipe size, furnished as welding stub-outs with Victaulic grooves, allowing the option of welding, flanges, or use of Victaulic couplings. Factory-installed, class 150 (ANSI B16.5, round slip-on, forged carbon steel with 1/16" raised face), water flanged nozzles are optional (add 1/2" to nozzle length). Companion flanges, nuts, bolts, and gaskets are not furnished.
- Compact water boxes on one heat exchanger may be used with Marine Water Boxes on the other heat exchanger.
- Water must enter the water box through the bottom connection to achieve rated performance.
- Add 1" if neoprene pads are supplied.

# Dimensions (Eng.) – Cond. Marine Water Boxes

## CONDENSERS – MARINE WATER BOXES – J COMPRESSOR UNITS

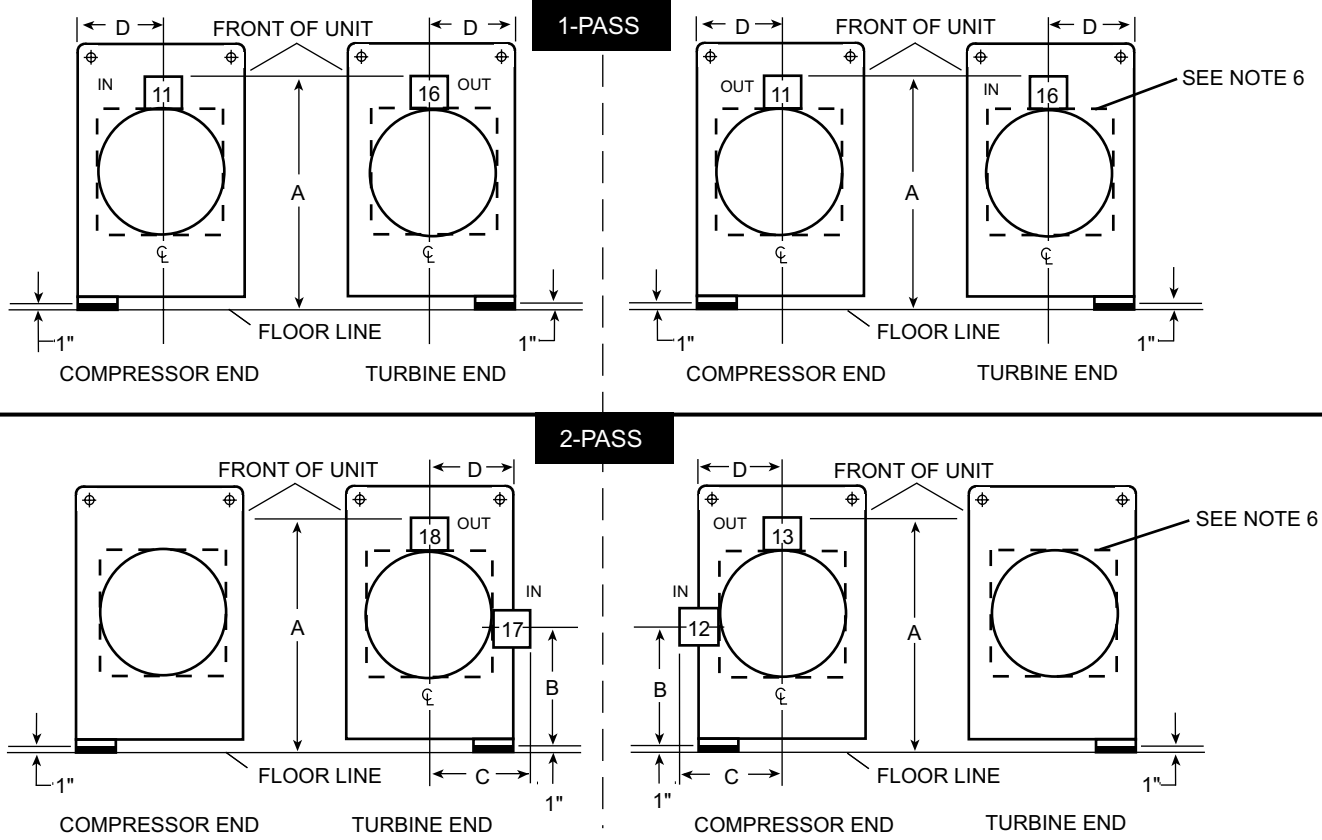

LD07991

COND. SHELL CODE	CONDENSER NOZZLE DIMENSIONS					
	1-PASS		2-PASS			
	A <sup>5</sup>	D	A <sup>5</sup>	B <sup>5</sup>	C	D
G	5'-9-3/4"	1'-9"	5'-9-3/4"	2'-8-3/4"	2'-5"	1'-9"
H	5'-11"	1'-11"	5'-10-1/4"	2'-0-3/4"	2'-1"	1'-11"
J	6'-3-3/8"	2'-1"	6'-2-3/8"	2'-1-1/2"	2'-1-1/8"	2'-1"
T	6'-3-3/8"	2'-1"	6'-2-3/8"	2'-1-1/2"	2'-1-1/8"	2'-1"
V	6'-8-3/4"	2'-3-1/2"	6'-8-1/8"	2'-1-3/4"	2'-5-3/8"	2'-3-1/2"

See Notes on page 28.

# Dimensions (Eng.) – Nozzle Arrangements

CONDENSER	
1-PASS	
IN	OUT
11	16
16	11

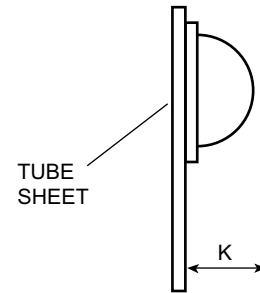
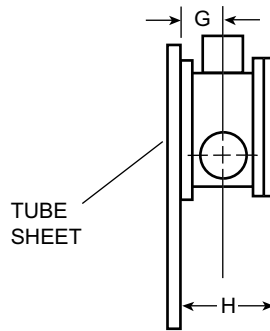

(2-PASS RETURN HEAD)

CONDENSER	
2-PASS	
IN	OUT
12	13
17	18

CONDENSER SHELL CODE	COND. NOZZLE DIMENSIONS (1-PASS)	
	G	H
	G	1'-1 1/4"
H	1'-3 1/2"	2'-8 3/4"
J	1'-3 1/2"	2'-8 7/8"
T	1'-3 1/2"	2'-8 7/8"
V	1'-3 1/2"	2'-9 3/8"

COND. SHELL CODE	NOZZLE PIPE SIZE NO. OF PASSES	
	1	2
G	16"	14"
H	20"	16"
J	20"	16"
T	20"	16"
V	20"	18"

CONDENSER SHELL CODE	COND. NOZZLE DIMENSIONS (2-PASS)		
	G	H	K
	G	1'-0 1/4"	2'-2 3/8"
H	1'-1 5/8"	2'-5"	0'-11 5/8"
J	1'-1 5/8"	2'-5 1/8"	1'-0 1/2"
T	1'-1 5/8"	2'-5 1/8"	1'-0 1/2"
V	1'-2 1/4"	2'-6 3/4"	1'-1 5/8"

**NOTES (see table on page 27):**

- All dimensions are approximate. Certified dimensions are available upon request.
- Standard water nozzles are Schedule 40 pipe size, furnished as welding stub-outs with Victaulic grooves, allowing the option of welding, flanges, or use of Victaulic couplings. Factory-installed, class 150 (ANSI B16.5, round slip-on, forged carbon steel with 1/16" raised face), water flanged nozzles are optional (add 1/2" to nozzle length). Companion flanges, nuts, bolts, and gaskets are not furnished.
- One- and two-pass nozzle arrangements are available only in pairs shown and for all shell codes. Any pair of evaporator nozzles may be used in combination with any pair of condenser nozzles. Compact water boxes on one heat exchanger may be used with Marine Water Boxes on the other heat exchanger.
- Condenser water must enter the water box through the bottom connection for proper operation of the sub-cooler to achieve rated performance.
- Add 1" if neoprene pads are supplied.
- "G" Condenser Water Boxes are square; other codes are round as shown.

# Dimensions (Ft. - In.) – Floor Mtd. Unit

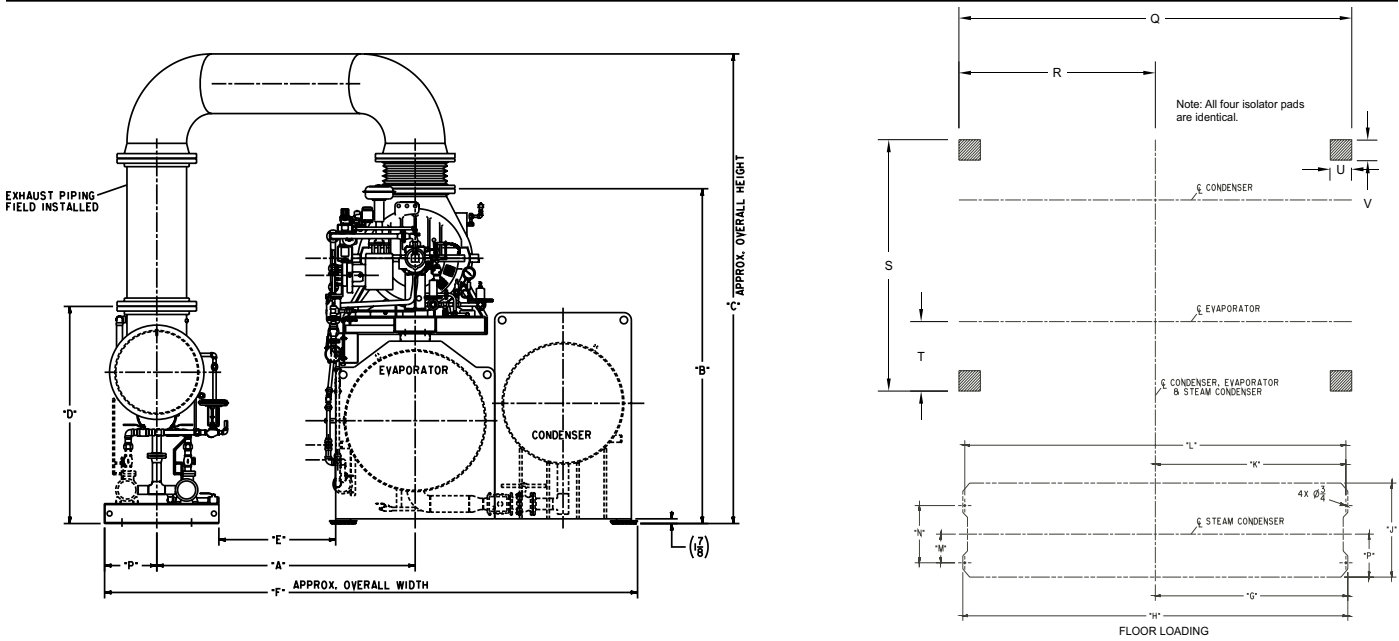

FLOOR MOUNTED UNIT DIMENSIONS

DIMENSION FT-IN	H-G-J1/J2-KG	H-H-J2-KG	J-J-J3-KG	J-J-J3-KD	T-T-J4-KD	V-V-J4-KD	W-V-J4-KD
	29168 STEAM COND 20" X 20" EXHAUST	31168 STEAM COND 24" X 20" EXHAUST	35168 STEAM COND 24" X 24" EXHAUST	35168 STEAM COND 24" X 24" EXHAUST	33192 STEAM COND 24" X 24" EXHAUST	33192 STEAM COND 24" X 24" EXHAUST	33192 STEAM COND 24" X 24" EXHAUST
A	8'	8'	8'-6"	8'-6"	8'-6"	8'-6"	8'-8"
B	9'-6-3/4"	9'-6-3/4"	10'-4-1/4"	10'-8-1/4"	10'-10-1/4"	11'-1/4"	11'-2-3/4"
C	13'-6"	14'-6"	15'	15'-4"	15'-6"	15'-8"	15'-10"
D	6'-11-3/8"	7'-1-3/8"	7'-5-3/8"	7'-5-3/8"	7'-3-3/8"	7'-3-3/8"	7'-3-3/8"
E	4'-3/4"	4'-3/4"	3'-11-1/2"	3'-11-1/2"	3'-11-1/2"	3'-11-1/2"	3'-11"
F	15'-4"	15'-8"	17'-1"	17'-1"	17'-1"	17'-6"	17'-10"
G	7'-2-1/2"	7'-2-1/2"	7'-2-1/2"	7'-2-1/2"	8'-2-1/2"	8'-2-1/2"	8'-2-1/2"
H	14'-5"	14'-5"	14'-5"	14'-5"	16'-5"	16'-5"	16'-5"
J	3'-4"	3'-4"	3'-10"	3'-10"	3'-10"	3'-10"	3'-10"
K	7'-1-1/2"	7'-1-1/2"	7'-1-1/2"	7'-1-1/2"	8'-1-1/2"	8'-1-1/2"	8'-1-1/2"
L	14'-3"	14'-3"	14'-3"	14'-3"	16'-3-1/2"	16'-3-1/2"	16'-3-1/2"
M	1'	1'	1'-2"	1'-2"	1'-2"	1'-2"	1'-2"
N	2'	2'	2'-4"	2'-4"	2'-4"	2'-4"	2'-4"
P	1'-7"	1'-7"	1'-9"	1'-9"	1'-9"	1'-9"	1'-9"
Q	14'-6"	14'-6"	14'-8"	14'-8"	16'-8"	16'-8"	16'-8-1/2"
R	7'-3"	7'-3"	7'-4"	7'-4"	8'-4"	8'-4"	8'-4-1/2"
S	7'-10-1/2"	8'-2-1/2"	9'-4"	9'-4"	9'-4"	9'-9"	10'-2"
T	2'-2-1/4"	2'-2-1/4"	2'-7"	2'-7"	2'-7"	2'-7"	2'-9-1/2"
U	8"	8"	10"	10"	10"	10"	10"
V	6"	6"	9"	9"	9"	9"	9"

# Form 3 Shipment Dimensions

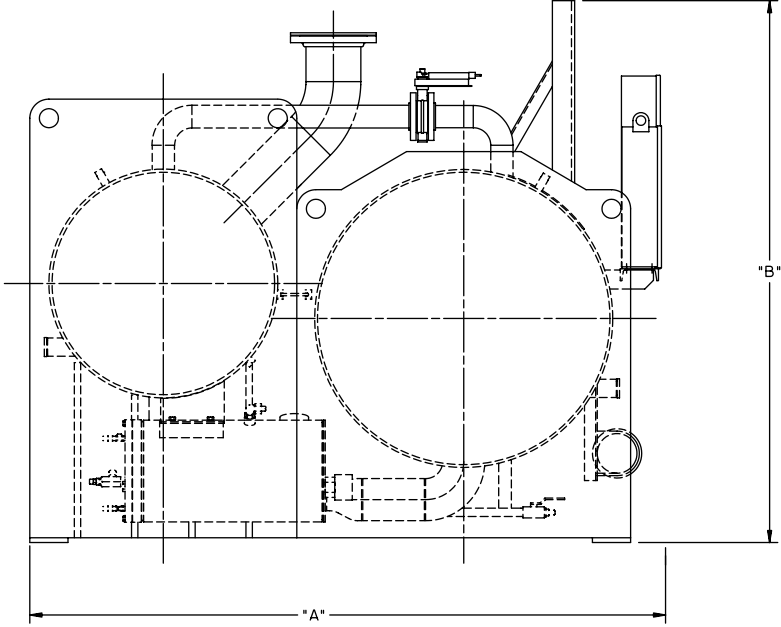

SHELLS/PANELS

UNIT	TURBINE	"A"	"B"	"C"	"D"	"E"	* LENGTH
W*V*J4	KD	126"	99"	133"	76"	72"	16'-0"
V*V*J4	KD	123"	97"	133"	76"	72"	16'-0"
T*T*J4	KD	118"	95"	133"	76"	72"	16'-0"
J*J*J3	KD	118"	93"	133"	76"	72"	14'-0"
J*J*J3	KG	115"	93"	136"	58"	62"	14'-0"
H*H*J2	KG	104"	89"	128"	53"	57"	14'-0"
H*G*JI	KG	100"	87"	128"	53"	57"	14'-0"

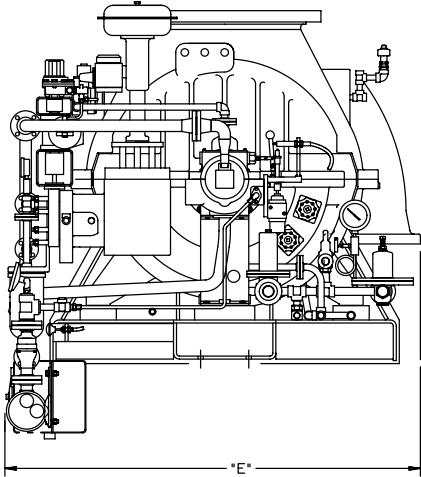
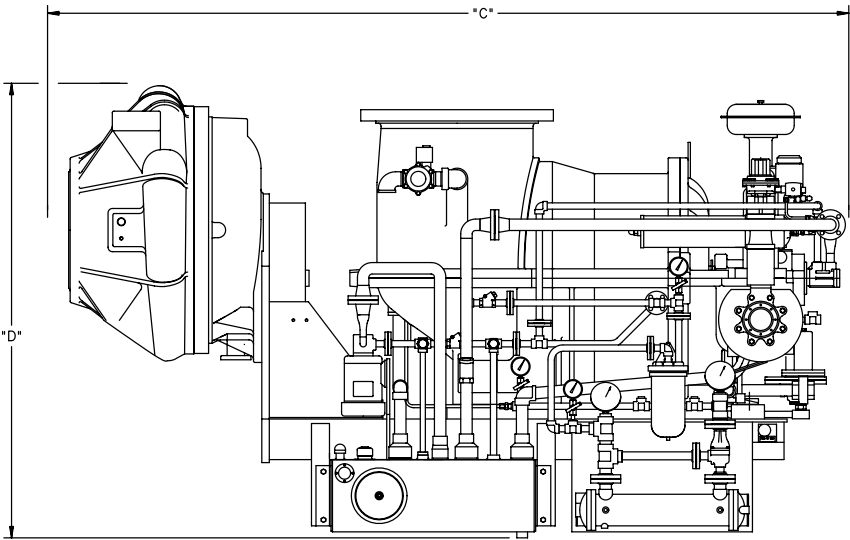

TURBINE/COMPRESSOR

# Form 7 Shipment Dimensions

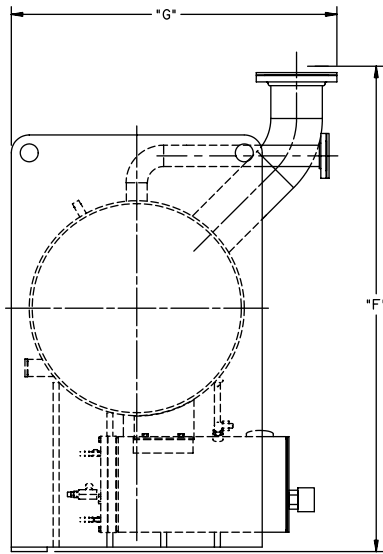

CONDENSER/OIL PUMP HOUSING

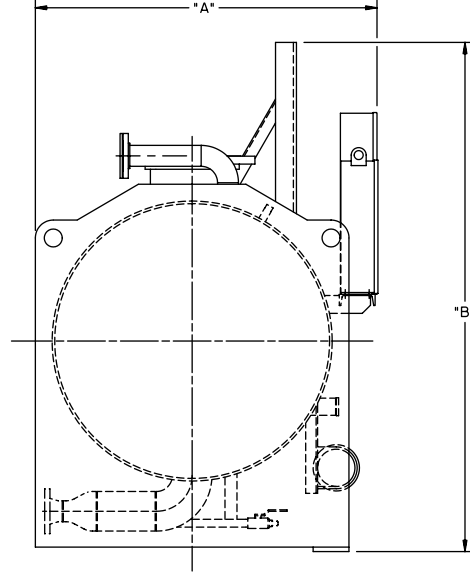

EVAPORATOR/COMPRESSOR OIL COOLER/PANELS

UNIT	TURBINE	"A"	"B"	"C"	"D"	"E"	"F"	"G"	* LENGTH
W#V#J4	KD	70"	99"	133"	76"	72"	97"	71"	16'-0"
V#V#J4	KD	65"	97"	133"	76"	72"	95"	69"	16'-0"
T#T#J4	KD	65"	95"	133"	76"	72"	92"	64"	16'-0"
J#J#J3	KD	65"	93"	133"	76"	72"	91"	64"	14'-0"
J#J#J3	KG	65"	93"	136"	58"	62"	91"	64"	14'-0"
H#H#J2	KG	58"	89"	128"	53"	57"	85"	59"	14'-0"
H#G#J1	KG	58"	87"	128"	53"	57"	82"	55"	14'-0"

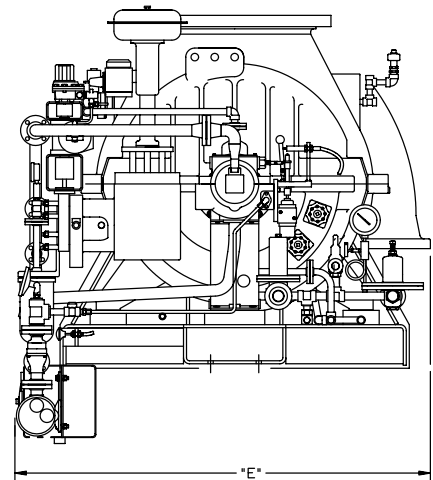
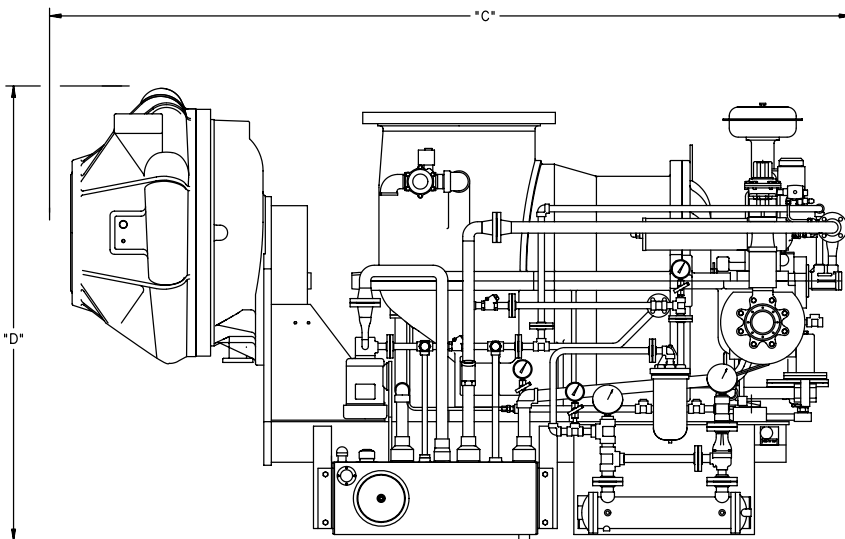

TURBINE/COMPRESSOR

J3 COMPRESSOR (J-J SHELLS)		
35168 STEAM CONDENSER		
DIMENSION CODE	KG STEAM TUR-	KD STEAM TUR-
	BINE	BINE
	FT-INCHES	FT-INCHES
A	10'-0"	10'-2"
B	9'-1"	9'-1"
C	2'-5-1/2"	2'-5-1/2"
D	2'-1"	2'-1"
E W/4" STEAM INLET	7'-8-3/4"	7'-7-1/2"
E W/6" STEAM INLET	7'-7-1/2"	7'-7-1/2"
F	17'-7"	17'-7"
G	14'-0"	14'-0"
I	6'-7-1/2"	TBD
J W/4" STEAM INLET	1'-9-3/16"	2'-5-1/4"

J4 COMPRESSOR			
KD STEAM TURBINE / 33192 STEAM CONDENSER			
SHELL CODE	T-T	V-V	W-V
DIMENSION CODE	FT-INCHES	FT-INCHES	FT-INCHES
A	10'-2"	10'-5"	10'-9"
B	9'-1"	9'-6"	9'-11"
C	2'-5-1/2"	2'-5-1/2"	2'-8"
D	2'-1"	2'-3-1/2"	2'-3-1/2"
E W/4" STEAM INLET	7'-9-1/2"	7'-11-1/2"	8'-2"
E W/6" STEAM INLET	7'-9-1/2"	7'-11-1/2"	8'-2"
F	17'-4"	17'-9"	17'-9"
G	16'-0"	16'-0"	16'-0"
I	TBD	TBD	TBD
J W/4" STEAM INLET	2'-5-1/4"	2'-5-1/4"	2'-5-1/4"
J W/6" STEAM INLET	2'-5-7/16"	2'-5-7/16"	2'-5-7/16"
K	0'-4-1/2"	0'-4-1/2"	0'-4"
L	16'-0-1/8"	16'-5-1/8"	16'-5-1/8"
M	11'-2"	11'-4"	11'-6"

DIMENSION "H" FOR ALL J COMPRESSOR MODELS		
STEAM CONDENSER MODEL 29168		
	1 PASS REFRIG. COND.	2 PASS REFRIG. COND.
SHELL CODE	FT-INCHES	FT-INCHES
H-G	26-15/16"	25-5/16"
STEAM CONDENSER MODEL 31168		
	1 PASS REFRIG. COND.	2 PASS REFRIG. COND.
SHELL CODE	FT-INCHES	FT-INCHES
H-G	27-5/16"	25-11/16"
H-H	31-11/16"	27-13/16"
STEAM CONDENSER MODEL 35168		
	1 PASS REFRIG. COND.	2 PASS REFRIG. COND.
SHELL CODE	FT-INCHES	FT-INCHES
J-J	32-3/16"	28-5/16"
STEAM CONDENSER MODEL 33192		
	1 PASS REFRIG. COND.	2 PASS REFRIG. COND.
SHELL CODE	FT-INCHES	FT-INCHES
T-T	31-15/16"	28-1/16"
V-V	31-15/16"	29-5/8"
W-V	31-15/16"	29-5/8"

# Steam Condenser (Eng.)

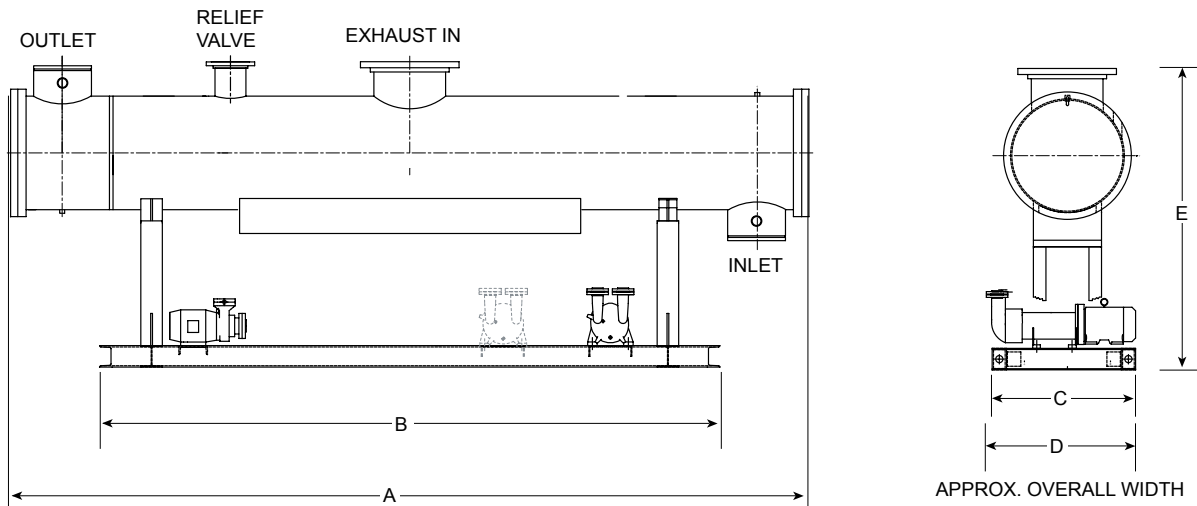

LD08001

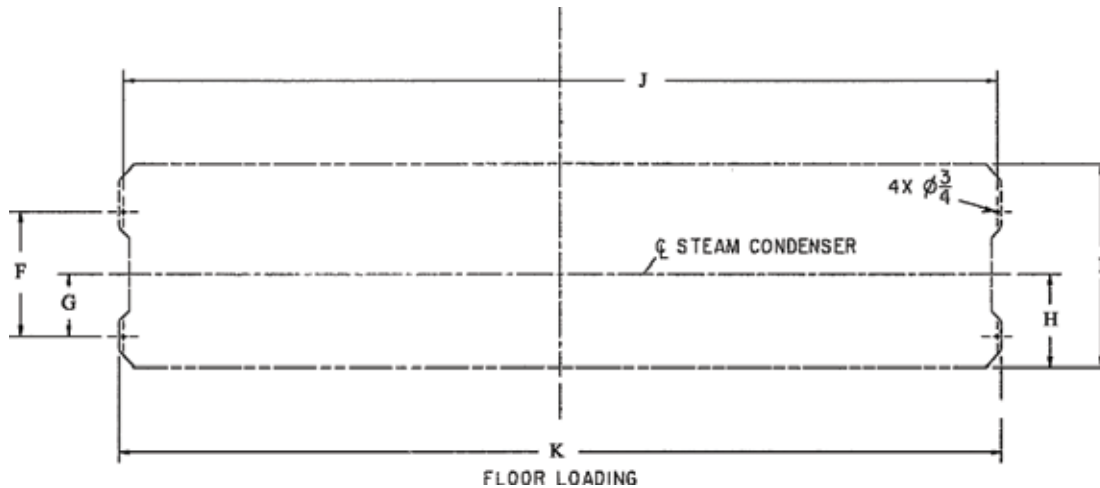

STEAM CONDENSER MODEL

DIMENSION CODE	29168 FT-INCHES	31168 FT-INCHES	35168 FT-INCHES	33192 FT-INCHES
B	14'-5"	14'-5"	14'-5"	16'-5"
C	3'-4"	3'-4"	3'-10"	3'-10"
D	4'-0"	4'-0"	4'-4"	4'-3"
E	6'-11-3/8"	7'-1-3/8"	7'-5-3/8"	7'-3-3/8"
F	2'-0"	2'-0"	2'-4"	2'-4"
G	1'-0"	1'-0"	1'-2"	1'-2"
H	1'-7"	1'-7"	1'-9"	1'-9"
I	3'-4"	3'-4"	3'-10"	3'-10"
J	14'-3"	14'-3"	14'-3"	16'-3"
K	14'-5"	14'-5"	14'-5"	16'-5"

DIMENSION "A" FOR ALL MODELS

Model	1 Pass Refrig. Cond.	2 Pass Refrig. Cond.
	ft-inches	ft-inches
29168	18'-5-7/8"	18'-2-5/8"
31168 w/H-G shells	18'-6-5/8"	18'-3-3/8"
31168 w/H-H shells	19'-3-3/8"	18'-7-5/8"
35168	19'-4-3/8"	18'-8-5/8"
33192 w/T-T shells	21'-3-7/8"	20'-8-1/8"
33192 w/V-V shells	21'-3-7/8"	20'-11-1/4"
33192 w/W-V shells	21'-3-7/8"	20'-11-1/4"



# Dimensions (mm) – Unit

## J COMPRESSOR UNITS

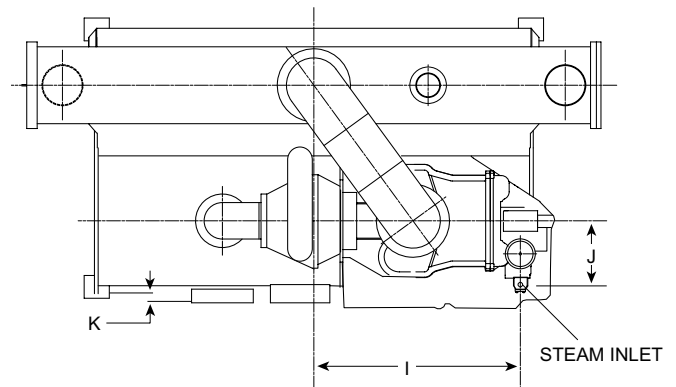
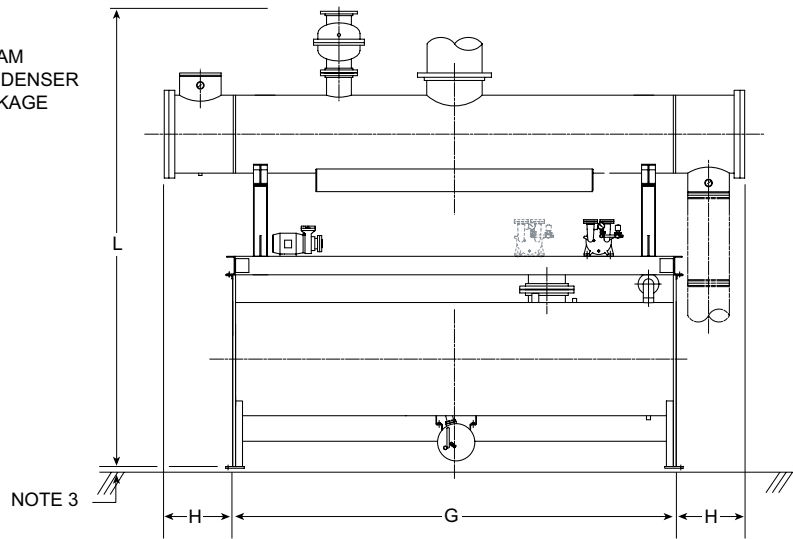
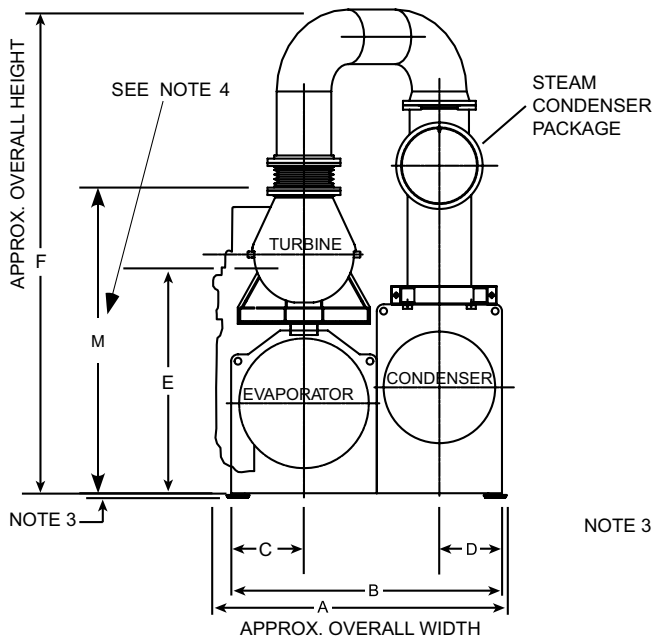

LD08000

J1 COMPRESSOR (H-G SHELLS)	
KG STEAM TURBINE / 29168 STEAM CONDENSER	
DIMENSION CODE	MM
A	2725
B	2401
C	667
D	534
E W/4 STEAM INLET "	2128
E W/6 STEAM INLET "	2096
F	4801
G	4268
I	2039
J W/4 STEAM INLET "	539
J W/6 STEAM INLET "	6
K	96
L	4445
M	3048

J2 COMPRESSOR		
KG STEAM TURBINE / 31168 STEAM CONDENSER		
SHELL CODE	H-G	H-H
DIMENSION CODE	MM	MM
A	2725	2794
B	2401	2502
C	667	667
D	534	585
E W/4 STEAM INLET "	2128	2204
E W/6 STEAM INLET "	2096	2172
F	4852	4953
G	4268	4268
I	2039	2042
J W/4 STEAM INLET "	539	539
J W/6 STEAM INLET "	6	6
K	96	96
L	4495	4596
M	3048	3124

**NOTES:**

1. All dimensions are approximate. Certified dimensions are available on request.
2. Water nozzles can be located on either end of unit. Add 13mm to nozzle length for flanges connections.
3. Add 44mm for neoprene pads or 19mm if neoprene pads are not supplied.

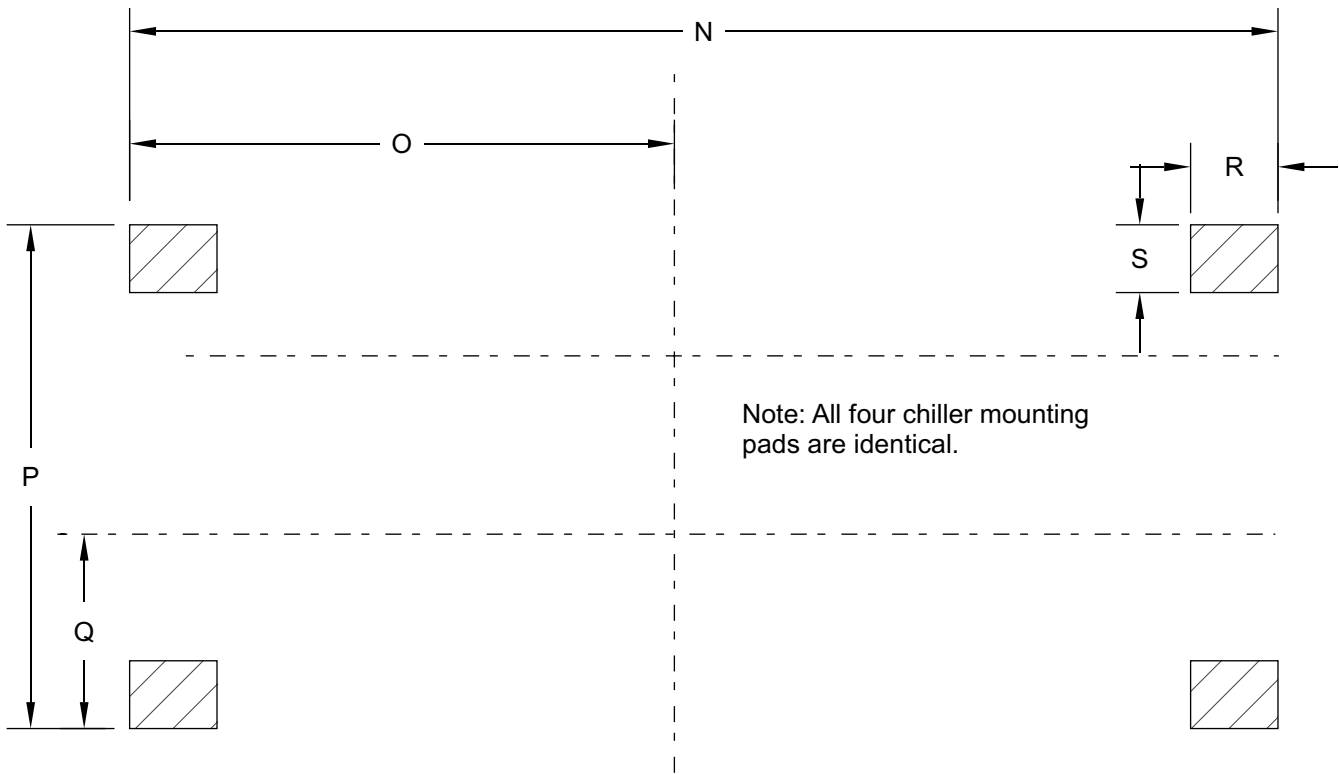

MODEL	N	O	P	Q	R	S
H-G-J1	4470	2235	2477	705	254	229
H-G-J2	4470	2235	2477	705	254	229
H-H-J2	4470	2235	2578	705	254	229
J-J-J3	4470	2235	2845	785	254	229
T-T-J4	5080	2540	2845	785	254	229
V-V-J4	5080	2540	2972	785	254	229
W-V-J4	5105	2553	3124	864	279	254

# Dimensions (mm) – Unit

J3 COMPRESSOR (J-J SHELLS)		
35168 STEAM CONDENSER		
	KG STEAM TURBINE	KD STEAM TURBINE
DIMENSION CODE	MM	MM
A	3048	3099
B	2769	2769
C	750	750
D	635	635
E W/4 STEAM INLET "	2356	2325
E W/6 STEAM INLET "	2325	2325
F	5360	5360
G	4268	4268
I	2020	TBD
J W/4 STEAM INLET "	539	743
J W/6 STEAM INLET "	6	748
K	115	115
L	4826	4826
M	3353	3353

J4 COMPRESSOR			
KD STEAM TURBINE / 33192 STEAM CONDENSER			
SHELL CODE	T-T	V-V	W-V
DIMENSION CODE	MM	MM	MM
A	3099	3175	3277
B	2769	2896	3023
C	750	750	813
D	635	699	699
E W/4 STEAM INLET "	2375	2426	2490
E W/6 STEAM INLET "	2375	2426	2490
F	5284	5411	5411
G	4877	4877	4877
I	TBD	TBD	TBD
J W/4 STEAM INLET "	743	743	743
J W/6 STEAM INLET "	748	748	748
K	115	115	102
L	4880	5007	5007
M	3404	3454	3505

DIMENSION H" FOR ALL J COMPRESSOR MODELS "		
STEAM CONDENSER MODEL 29168		
	1 PASS REFRIG. COND.	2 PASS REFRIG. COND.
SHELL CODE	MM	MM
H-G	685	643
STEAM CONDENSER MODEL 31168		
	1 PASS REFRIG. COND.	2 PASS REFRIG. COND.
SHELL CODE	MM	MM
H-G	694	653
H-H	805	707
STEAM CONDENSER MODEL 35168		
	1 PASS REFRIG. COND.	2 PASS REFRIG. COND.
SHELL CODE	MM	MM
J-J	818	720
STEAM CONDENSER MODEL 33192		
	1 PASS REFRIG. COND.	2 PASS REFRIG. COND.
SHELL CODE	MM	MM
T-T	812	713
V-V	812	753
W-V	812	753

# Dimensions (mm) – Nozzle Arrangements

## EVAPORATORS – COMPACT WATER BOXES – J COMPRESSOR UNITS

1-PASS

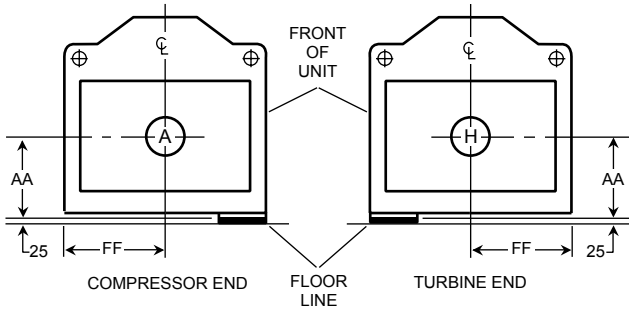

NOZZLE ARRANGEMENTS		
NO. OF PASSES	EVAPORATOR	
	IN	OUT
1	A	H
	H	A

2-PASS

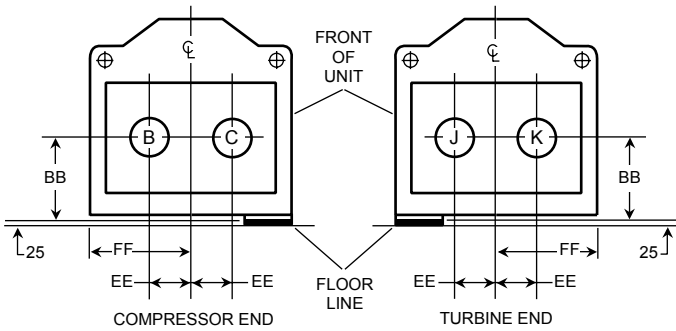

NOZZLE ARRANGEMENTS		
NO. OF PASSES	EVAPORATOR	
	IN	OUT
2	B	C
	C	B
	J	K
	K	J

3-PASS

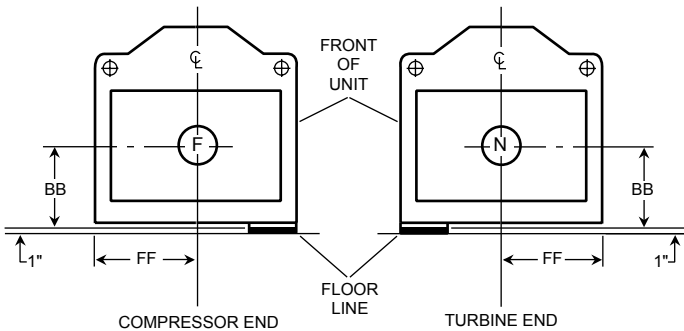

NOZZLE ARRANGEMENTS		
NO. OF PASSES	EVAPORATOR	
	IN	OUT
3	F	N
	N	F

LD07990A

EVAP. SHELL CODE	NOZZLE PIPE SIZE			EVAPORATOR NOZZLE DIMENSIONS (mm)						
	NO. OF PASSES			1-PASS		2-PASS			3-PASS	
	1	2	3	AA <sup>2</sup>	FF	BB <sup>2</sup>	EE	FF	BB <sup>2</sup>	FF
H F	16"	12"	10"	629	667	629	279	667	629	667
HH	16"	12"	10"	648	667	648	279	667	648	667
J	18"	14"	12"	654	749	654	279	749	654	749
T	18"	14"	12"	654	749	654	279	749	654	749
V	20"	16"	12"	743	749	743	330	749	743	749
W	20"	18"	14"	794	813	794	381	813	794	813

### NOTES:

- Standard water nozzles are furnished as welding stub-outs with Victaulic grooves, allowing the option of welding, flanges, or use of Victaulic couplings. Factory-installed, class 150 (ANSI B16.5, round slip-on, forged carbon steel with 1.6 mm raised face), water flanged nozzles are optional (add 13 mm to nozzle length). Companion flanges, nuts, bolts, and gaskets are not furnished.
- Add 25 mm if neoprene pads are supplied.
- One-, two- and three-pass nozzle arrangements are available only in pairs shown and for all shell codes. Any pair of evaporator nozzles may be used in combination with any pair of condenser nozzles.
- Connected piping should allow for removal of compact water boxes for tube access and cleaning.

**EVAPORATORS – MARINE WATER BOXES – J COMPRESSOR UNITS**

COMPR. CODE	EVAP-COND SHELL CODE	G	H
J1, J2	H-G	375	603
	H-H	375	603
	J-J	375	603
J3, J4	T-T	375	603
	V-V	375	603
	W-V	419	629

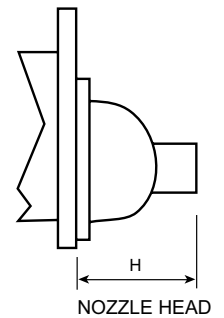
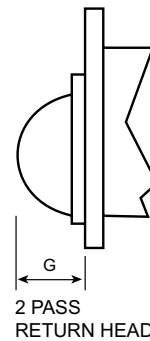

LD08639

**2-PASS**

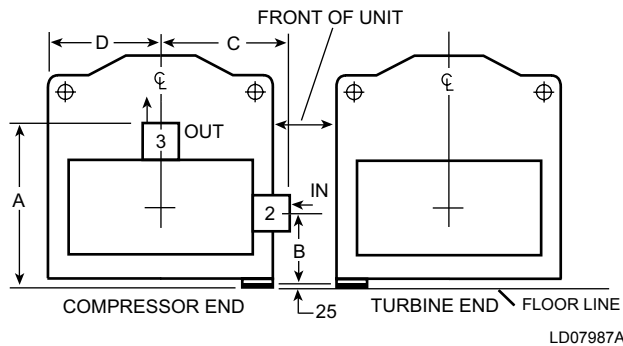

EVAP. SHELL CODE	EVAPORATOR NOZZLE DIMENSIONS (mm)			
	2-PASS			
	A <sup>5</sup>	B <sup>5</sup>	C	D
H F	1,353	679	794	667
H H	1,372	514	794	667
J	1,213	552	870	749
T	1,213	552	870	749
V	1,302	648	870	749
W	1,384	698	965	762

EVAPORATOR	
2-PASS	
IN	OUT
2	3

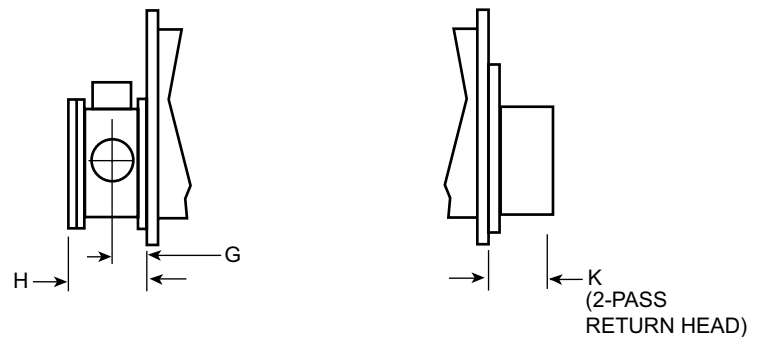

LD07999

EVAPORATOR SHELL CODE	NOZZLE PIPE SIZE
	NO. OF PASSES
	2
H	12"
J	14"
T	14"
V	16"
W	18"

EVAPORATOR SHELL CODE	EVAPORATOR NOZZLE DIMENSIONS (2-PASS)		
	G	H	K
H	289	629	375
J	314	679	375
T	314	679	375
V	356	762	375
W	381	762	419

**NOTES:**

- All dimensions are approximate. Certified dimensions are available upon request.
- Standard water nozzles are Schedule 40 pipe size, furnished as welding stub-outs with Victaulic grooves, allowing the option of welding, flanges, or use of Victaulic couplings. Factory-installed, class 150 (ANSI B16.5, round slip-on, forged carbon steel with 1.6 mm raised face), water flanged nozzles are optional (add 13 mm to nozzle length). Companion flanges, nuts, bolts, and gaskets are not furnished.
- Any pair of evaporator nozzles may be used in combination with any pair of condenser nozzles. Compact water boxes on one heat exchanger may be used with Marine Water Boxes on the other heat exchanger.
- Water must enter the water box through the bottom connection to achieve rated performance.
- Add 25 mm if neoprene pads are supplied.

# Dimensions (mm) – Nozzle Arrangements

## CONDENSERS – MARINE WATER BOXES – J COMPRESSOR UNITS

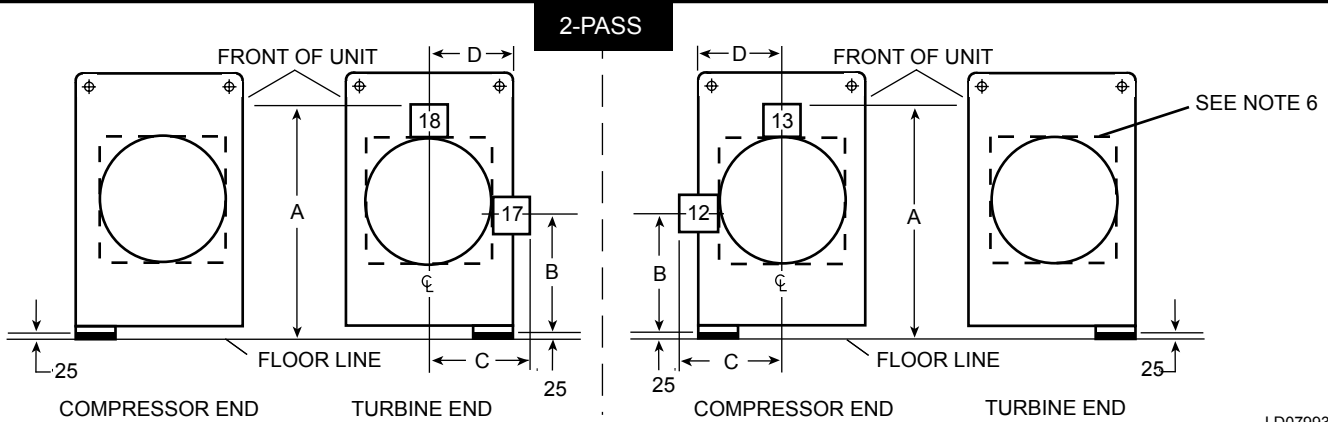
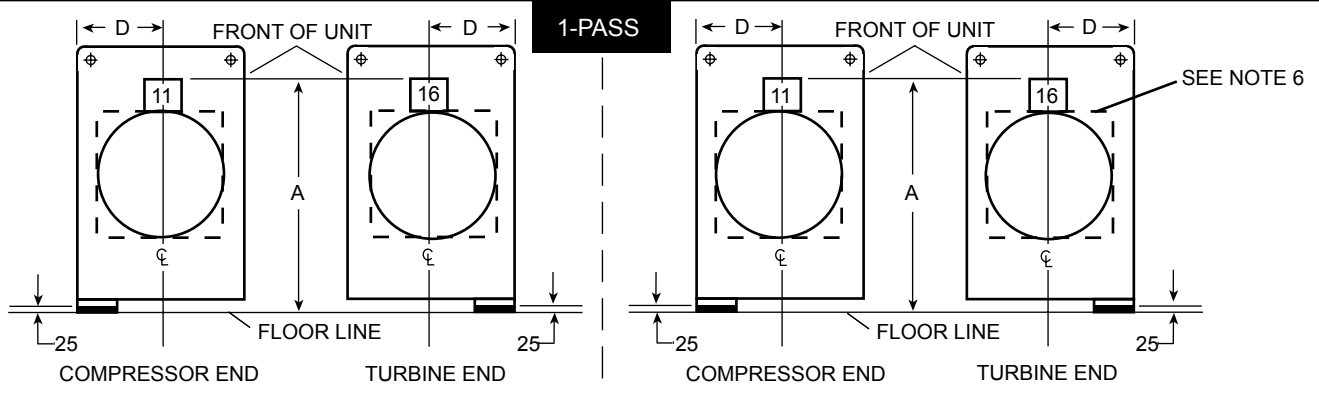

LD07993

COND. SHELL CODE	CONDENSER NOZZLE DIMENSIONS					
	1-PASS		2-PASS			
	A <sup>5</sup>	D	A <sup>5</sup>	B <sup>5</sup>	C	D
G	1,772	533	1,772	832	737	533
H	1,803	584	1,784	629	635	584
J	1,915	635	1,889	648	638	635
T	1,915	635	1,889	648	638	635
V	2,051	699	2,035	654	746	699

See Notes on page 40.

CONDENSER	
1-PASS	
IN	OUT
11	16
16	11

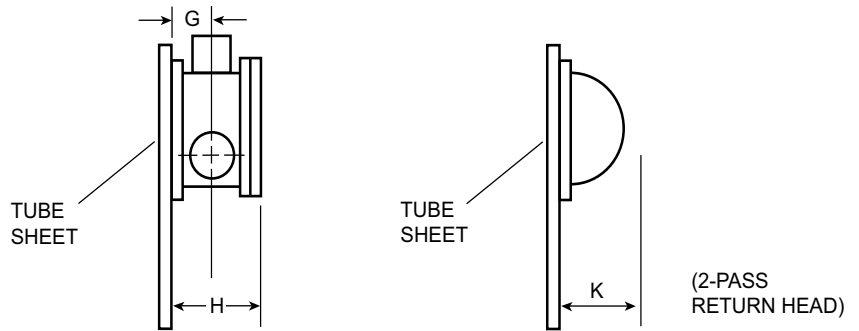

LD07183

CONDENSER	
2-PASS	
IN	OUT
12	13
17	18

CONDENSER SHELL CODE	COND. NOZZLE DIMENSIONS (1-PASS)	
	G	H
G	337	721
H	394	832
J	394	835
T	394	835
V	394	848

COND. SHELL CODE	NOZZLE PIPE SIZE	NO. OF PASSES	
		1	2
G 16"	14"		
H 20"	16"		
J 20"	16"		
T 20"	16"		
V 20"	18"		

CONDENSER SHELL CODE	COND. NOZZLE DIMENSIONS (2-PASS)		
	G	H	K
G	311	670	149
H	346	737	295
J	346	740	318
T	346	740	318
V	362	781	346

**NOTES (see Table on page 39):**

1. All dimensions are approximate. Certified dimensions are available upon request.
2. Standard water nozzles are Schedule 40 pipe size, furnished as welding stub-outs with Victaulic grooves, allowing the option of welding, flanges, or use of Victaulic couplings. Factory-installed, class 150 (ANSI B16.5, round slip-on, forged carbon steel with 1.6 mm raised face), water flanged nozzles are optional (add 13 mm to nozzle length). Companion flanges, nuts, bolts, and gaskets are not furnished.
3. One- and two-pass nozzle arrangements are available only in pairs shown and for all shell codes. Any pair of evaporator nozzles may be used in combination with any pair of condenser nozzles. Compact water boxes on one heat exchanger may be used with Marine Water Boxes on the other heat exchanger.
4. Condenser water must enter the water box through the bottom connection for proper operation of the sub-cooler to achieve rated performance.
5. Add 25 mm if neoprene pads are supplied.

# Dimensions (mm) – Floor Mtd. Unit

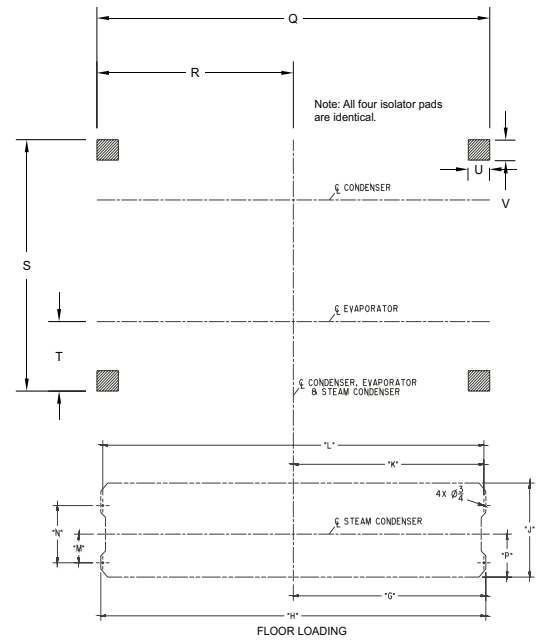
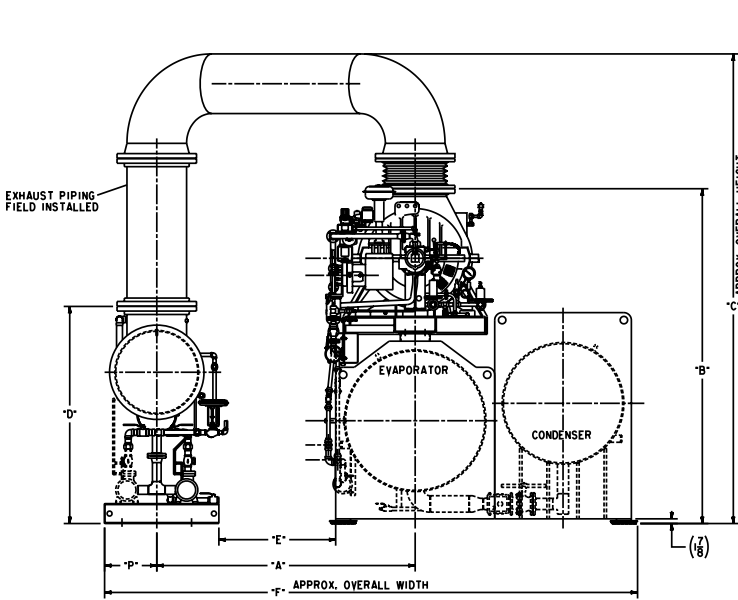

FLOOR MOUNTED UNIT DIMENSIONS

DIMENSION MM	H-G-J1/J2-KG	H-H-J2-KG	J-J-J3-KG	J-J-J3-KD	T-T-J4-KD	V-V-J4-KD	W-V-J4-KD
	29168 STEAM COND 20 X 20" EXHAUST "	31168 STEAM COND 24 X 20" EXHAUST "	35168 STEAM COND 24 X 24" EXHAUST "	35168 STEAM COND 24 X 24" EXHAUST "	33192 STEAM COND 24 X 24" EXHAUST "	33192 STEAM COND 24 X 24" EXHAUST "	33192 STEAM COND 24 X 24" EX- HAUST "
A	2438	2438	2591	2591	2591	2591	2642
B	2915	3042	3156	3258	3308	3359	3423
C	4115	4420	4572	4674	4724	4775	4826
D	2118	2169	2270	2270	2219	2219	2219
E	1238	1238	1207	1207	1207	1207	1194
F	4674	4775	5207	5207	5207	5334	5436
G	2197	2197	2197	2197	2502	2502	2502
H	4394	4394	4394	4394	5004	5004	5004
J	1016	1016	1168	1168	1168	1168	1168
K	2172	2172	2172	2172	2477	2477	2477
L	4343	4343	4343	4343	4953	4953	4953
M	305	305	356	356	356	356	356
N	610	610	711	711	711	711	711
P	483	483	533	533	533	533	533
Q	4470	4470	4470	4470	5080	5080	5105
R	2235	2235	2235	2235	2540	2540	2553
S	2477	2477	2578	2845	2845	2972	3124
T	705	705	705	787	787	787	864
U	3048	3048	3048	3048	3048	3048	3353
V	2743	2743	2743	2743	2743	2743	3048



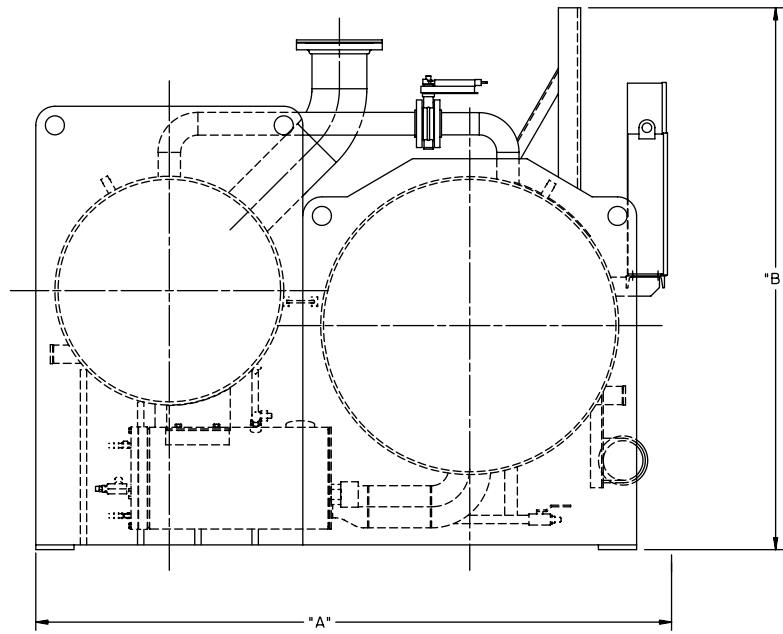

SHELLS/PANELS

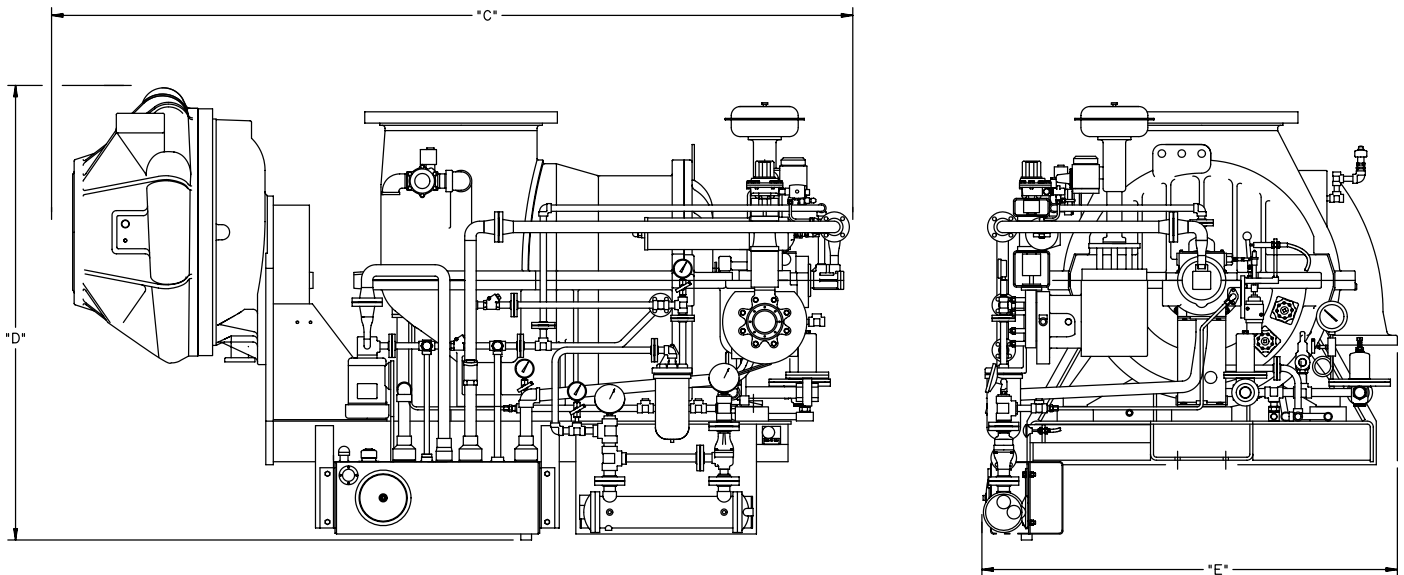

TURBINE/COMPRESSOR

# Dimensions (Mm) – Floor Td. Unit - Continued

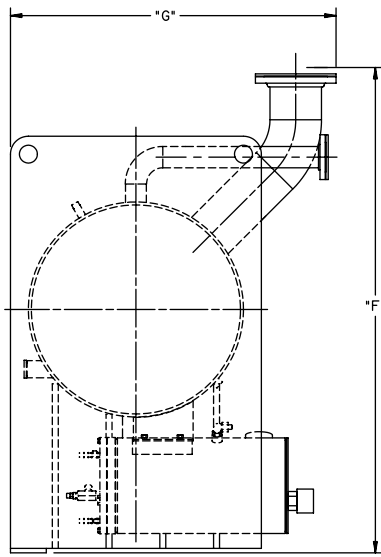

CONDENSER/OIL PUMP HOUSING

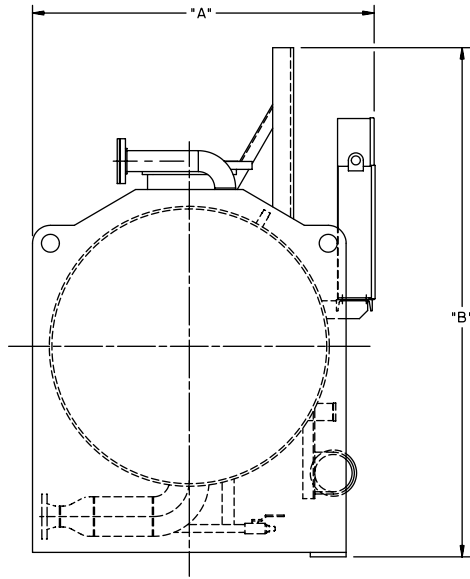

EVAPORATOR/COMPRESSOR OIL  
COOLER/PANELS

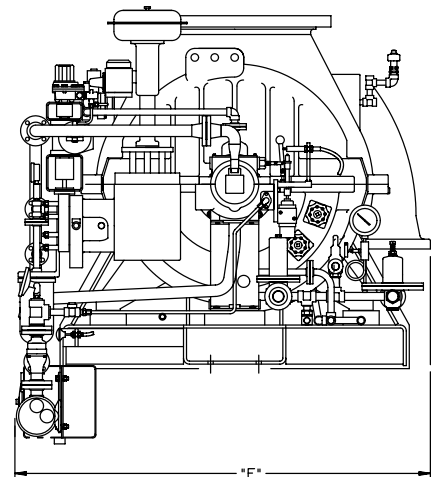
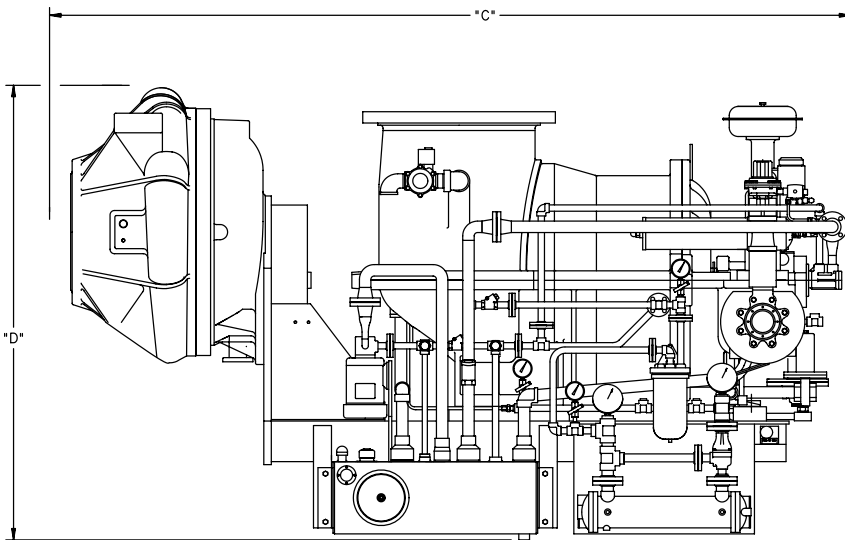

TURBINE/COMPRESSOR



# Steam Condenser (mm)

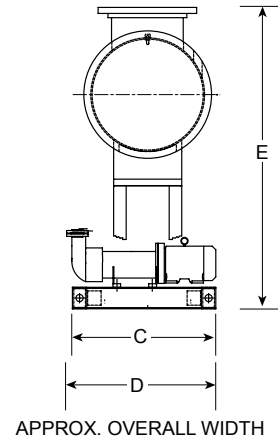
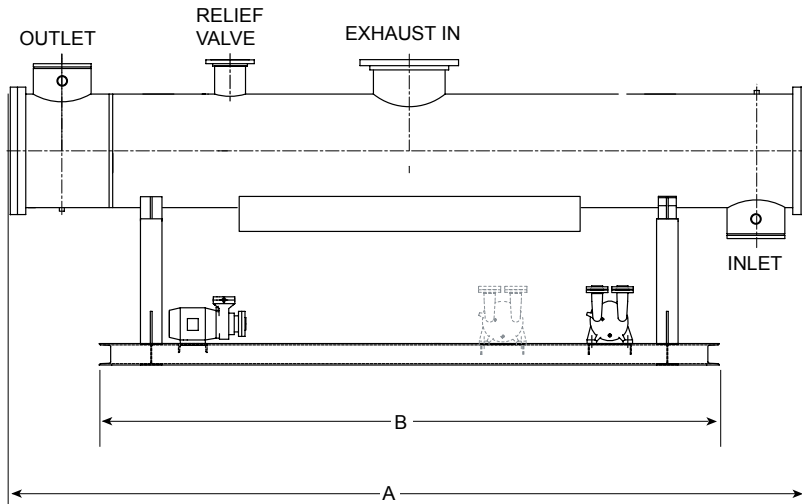

LD08001

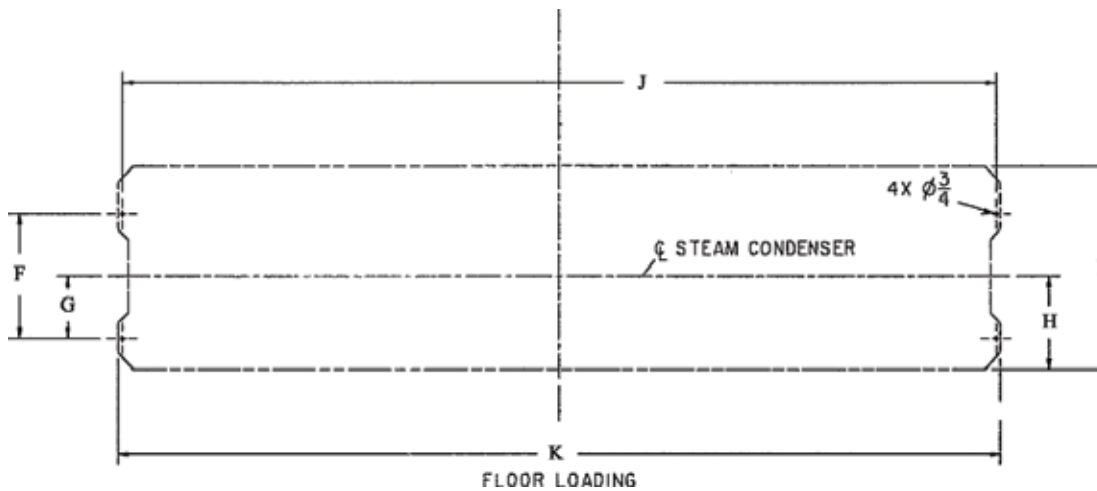

STEAM CONDENSER MODEL				
	29168	31168	35168	33192
DIMENSION CODE	MM	MM	MM	MM
B	4395	4395	4395	5004
C	1016	1016	1169	1169
D	1220	1220	1321	1296
E	2118	2169	2271	2220
F	610	610	711	711
G	305	305	356	356
H	483	483	533	533
I	1016	1016	1168	1168
J	4343	4343	4343	4953
K	4394	4394	4394	5004

MODEL	1 PASS REFRIG. COND.	2 PASS REFRIG. COND.
	MM	MM
29168	5636	5554
31168 W/H-G SHELLS	5655	5573
31168 W/H-H SHELLS	5877	5681
35168	5903	5706
33192 W/T-T SHELLS	6500	6303
33192 W/V SHELLS	6500	6382
33192 W/W-V SHELLS	6500	6382

EVAPORATOR WEIGHTS - SHIPPING			
SHELL CODE	COMPRESSOR CODE	TOTAL SHELL WEIGHT	TOTAL SHELL WEIGHT
		LBS	KG
HF	J1/J2	10,317	4,679
HH	J1/J2	10,831	4,912
JF	J3	13,168	5,972
JG	J3	13,489	6,117
JH	J3	13,808	6,262
TF	J4	14,575	6,610
TG	J4	14,945	6,778
TH	J4	15,317	6,946
VF	J4	15,722	7,130
VH	J4	16,268	7,378
WF	J4	18,796	8,524
WH	J4	20,023	9,081

Note: Based on standard evaporator tubes, MTI #272.

SUCTION ELBOW WEIGHT**		
COMPRESSOR CODE	ELBOW WEIGHT - LBS	ELBOW
J1/J2	600	272
J3/J4	700	317

\*\*SUCTION ELBOW SHIPS LOOSE FOR FORM 3 OR 7 BREAKDOWN SHIPMENTS.

REFRIGERANT CONDENSER WEIGHTS - SHIPPING			
SHELL CODE	COMPRESSOR CODE	TOTAL CONDENSER	TOTAL CONDENSER
		SHIPPING WEIGHT	SHIPPING WEIGHT
		LBS	KG
GB	J1/J2	9,228	4,185
GD	J1/J2	9,888	4,484
HB	J2	11,635	5,277
HD	J2	12,068	5,473
JB	J3	13,619	6,176
JD	J3	14,330	6,499
TB	J4	15,187	6,888
TD	J4	16,009	7,260
VB	J4	18,168	8,239
VD	J4	19,276	8,742

BASED ON STANDARD CONDENSER TUBES, MTI #261. INCLUDES OIL RESERVOIR DRY WEIGHT.

# Weights

150 LB DWP EVAPORATOR WATERBOX WEIGHTS									
SHELL CODE	COMPRESSOR CODE	SHIPPING WEIGHT							
		COMPACT STYLE WATERBOXES						MARINE STYLE WATERBOXES	
		1 PASS		2 PASS		3 PASS		2 PASS	
		(LBS)	(KG)	(LBS)	(KG)	(LBS)	(KG)	(LBS)	(KG)
H	J1/J2	980	444	1,035	469	1,060	530	2,615	1,186
J/T	J3/J4	1,075	488	1,115	506	1,165	528	2,900	1,315
V	J4	1,100	499	1,130	512	1,170	531	3,015	1,367
W	J4	1,300	590	1,390	630	1,400	635	3,740	1,696

**Notes:**

Weights shown for 2 pass waterboxes includes weight of return head.

Weights are for victaulic groove only (mechanical fittings not included). Flange weight, if applicable, must be added separately.

Weights shown for 1 or 3 pass waterboxes is the total of both boxes.

150 LB DWP REFRIGERANT CONDENSER WATERBOX WEIGHTS					
SHELL CODE	COMPRESSOR CODE	SHIPPING WEIGHT			
		MARINE STYLE WATERBOXES			
		1 PASS		2 PASS	
		(LBS)	(KG)	(LBS)	(KG)
G	J1/J2	4,090	1,855	2,785	1,263
H	J2	3,785	1,717	2,270	1,029
J/T	J3/J4	4,580	2,077	2,745	1,245
V	J4	5,375	2,438	3,280	1,488

**Notes:**

Weights are for victaulic groove only (mechanical fittings not included). Flange weight, if applicable, must be added separately.

Weights shown for 2 pass waterboxes includes weight of return head.

Weights shown for 1 pass waterboxes is the total of both boxes.

STEAM CONDENSER PACKAGE WEIGHTS		
STEAM COND MODEL	SHIPPING WEIGHT (LBS)	SHIPPING WEIGHT (KG)
29168A	12,615.00	5,721
29168B	12,873.00	5,838
29168C	13,135.00	5,957
29168D	13,397.00	6,076
31168B (16)	14,125.00	6,406
31168B (20)	14,265.00	6,469
31168C (16)	14,454.00	6,555
31168C (20)	14,594.00	6,619
31168D (16)	14,784.00	6,705
31168D (20)	14,924.00	6,768
33192B	16,293.00	7,389
33192C	16,687.00	7,568
33192D	17,115.00	7,762
35168B	16,655.00	7,553
35168C	17,051.00	7,733
35168D	17,452.00	7,915

NOTE: Steam Condenser package weight for model 31168 varies depending on 16" or 20" nozzle size.

STEAM COND DUAL PUMP OPTION WEIGHT ADDER:	592 LBS	269 KG
ADDITIONAL CONDENSATE PUMP ONLY:	112 LBS	51 KG
ADDITIONAL VACUUM PUMP ONLY:	480 LBS	218 KG

STEAM TURBINE PACKAGE WEIGHTS		
TURBINE BASE MODEL	SHIPPING WEIGHT (LBS)	SHIPPING WEIGHT (KG)
K2G5	8,175	3,708
K2G7/KG8	8,675	3,935
KD7	12,180	5,434

STEAM TURBINE PACKAGE - BREAKDOWN SHIPPING WEIGHTS				
TURBINE BASE MODEL	STEAM TURBINE (LBS)	DRIVELINE BASE (LBS)	STEAM TURBINE (KG)	DRIVELINE BASE (KG)
K2G5	6,500	1,675	2,949	760
K2G7/KG8	7,000	1,675	3,175	760
KD7	10,200	1,980	4,536	898

COMPRESSOR WEIGHTS		
COMPRESSOR CODE	WEIGHT - LBS	WEIGHT - KG
J1	4,000	1,814
J2	4,000	1,814
J3	5,000	2,268
J4	5,000	2,268

MISCELLANEOUS PIPING WEIGHT (STEAM TRUNK AND WATER PIPING TO STEAM CONDENSER) - LBS								
STEAM TRUNK SIZE	REFRIGERANT CONDENSER OUTLET / STEAM CONDENSER INLET NOZZLE SIZE							
	14 "		16 "		18 "		20 "	
	VICT. GROOVE	FLANGES	VICT. GROOVE	FLANGES	VICT. GROOVE	FLANGES	VICT. GROOVE	FLANGES
24 X 24" "	2,015	2,200	2,060	2,260	2,085	2,350	2,110	2,450
24 X 20" "	1,705	1,890	1,750	1,950	1,775	2,040	1,800	2,140
20 X 20" "	1,565	1,750	1,610	1,810	1,635	1,900	1,660	2,000

MISCELLANEOUS PIPING WEIGHT (STEAM TRUNK AND WATER PIPING TO STEAM CONDENSER) - KG								
STEAM TRUNK SIZE	REFRIGERANT CONDENSER OUTLET / STEAM CONDENSER INLET NOZZLE SIZE							
	14 "		16 "		18 "		20 "	
	VICT. GROOVE	FLANGES	VICT. GROOVE	FLANGES	VICT. GROOVE	FLANGES	VICT. GROOVE	FLANGES
24 X 24" "	914	998	934	1,025	946	1,066	957	1,111
24 X 20" "	773	857	794	885	805	925	816	971
20 X 20" "	710	794	730	821	742	862	753	907

Weight of expansion joint is included.

Mechanical fittings for victaulic connections are NOT included in York scope of supply. All fittings are provided by field.

FLANGE WEIGHT ADDERS		
SIZE	WEIGHT (PAIR)	
	LBS	KG
12	114	52
14	162	73
16	220	100
18	250	113
20	330	150

MISCELLANEOUS PIPING AND WIRING WEIGHT	LBS	KG
	1,000	454

THERMAL INSULATION OPTION	LBS	KG
	125	57
SHIPPING SKIDS	LBS	KG
	400	181

SHELL PACKAGE OPERATING WEIGHT (ADDITIONAL WATER, REFRIGERANT AND OIL WEIGHT ONLY)								
COMPR.	SHELLS		WATER WEIGHT		REFRIGERANT WEIGHT		OIL WEIGHT	
	(LBS)	(KG)	(LBS)	(KG)	(LBS)	(KG)		
J1/J2	H-G	HFGB	2,835	1,286	2625	1190	200	91
HFGD	3,095	1,404						
HHGB	3,065	1,390						
HHGD	3,325	1,508						
J2	H-H	HFHB	3,380	1,533	2825	1281		
HFHD	3,555	1,612						
HHHB	3,615	1,639						
HHHD	3,785	1,717						
J3	J-J	JFJB	4,385	1,989	3495	1585		
JFJD	4,665	2,116						
JGJB	4,530	2,054						
JGJD	4,815	2,184						
JHJB	4,680	2,122						
JHJD	4,960	2,249	5,010	2,272	3995	1812		
J4	T-T	TFTB						
TFTD	5,330	2,417						
TGTB	5,180	2,349						
TGTD	5,500	2,494						
THTB	5,345	2,424						
THTD	5,670	2,571	6,385	2,896	4150	1882		
J4	V-V	VFVB						
VFVD	6,820	3,093						
VHVB	6,635	3,009						
VHVD	7,070	3,206						
J4	W-V	WFVB	7,050	3,197	4460	2023		
WFVD	7,490	3,397						
WHVB	7,610	3,451						
WHVD	8,045	3,649						

Water weights based on standard evaporator tube MTI #272 and standard condenser tube MTI #261.

150 LB DWP EVAPORATOR WATERBOX WEIGHTS					
SHELL CODE	COMPRESSOR CODE	OPERATING WEIGHT (ADDITIONAL WATER WEIGHT ONLY)			
		COMPACT STYLE WATERBOXES 1, 2 OR 3 PASS		MARINE STYLE WATERBOXES 2 PASS	
		(LBS)	(KG)	(LBS)	(KG)
H	J1/J2	750	304	1,240	562
J/T	J3/J4	905	410	1,540	698
V	J4	1,020	463	1,800	816



150 LB DWP REFRIGERANT CONDENSER WATERBOX WEIGHTS					
SHELL CODE	COMPRESSOR CODE	OPERATING WEIGHT (ADDITIONAL WATER WEIGHT ONLY)			
		1 PASS		2 PASS	
		MARINE STYLE WATERBOXES			
		(LBS)	(KG)	(LBS)	(KG)
G	J1/J2	2,925	1,327	1,610	730
H	J2	2,970	1,347	1,880	853
J/T	J3/J4	3,550	1,610	2,215	1,005

STEAM COND. FLOODED WEIGHT (ADDITIONAL WATER WEIGHT ONLY)		
STEAM COND MODEL	LBS	KG
29168A	5,644	2,560
29168B	5,644	2,560
29168C	5,644	2,560
29168D	5,644	2,560
31168B (16)	6,426	2,914
31168B (20)	6,426	2,914
31168C (16)	6,426	2,914
31168C (20)	6,426	2,914
31168D (16)	6,426	2,914
31168D (20)	6,426	2,914
33192B	7,907	3,586
33192C	7,907	3,586
33192D	7,907	3,586
35168B	8,444	3,829
35168C	8,444	3,829
35168D	8,444	3,829

# Guide Specifications

## GENERAL

Furnish and install where indicated on the drawings \_\_\_\_ YORK YST **MaxE** Centrifugal Liquid Chilling Unit(s). Each unit shall produce a capacity \_\_\_\_ of tonR, cooling \_\_\_\_ GPM of \_\_\_\_ from \_\_\_\_ °F to \_\_\_\_ °F when supplied with \_\_\_\_ GPM of condenser water at \_\_\_\_ °F. Steam consumption shall not exceed \_\_\_\_ lbs/hr with an IPLV (APLV) of \_\_\_\_\_. The evaporator shall be selected for \_\_\_\_ hrft<sup>2</sup>/BTU fouling factor and a maximum liquid pressure drop of \_\_\_\_ ft. Water side shall be designed for \_\_\_\_ psig working pressure. The refrigerant condenser shall be selected for \_\_\_\_ hrft<sup>2</sup>/BTU fouling factor and the steam condenser shall have a cleanliness factor of \_\_\_\_\_. The maximum refrigerant and steam condenser pressure drop shall be \_\_\_\_ ft. Waterside shall be designed for \_\_\_\_ psig working pressure. Steam shall be supplied to the turbine at \_\_\_\_ psig and \_\_\_\_ °F.

(or)

Furnish and install where indicated on the drawings \_\_\_\_ YORK YST **MaxE** Centrifugal Liquid Chilling Unit(s). Each unit shall produce a capacity of \_\_\_\_ kW, cooling \_\_\_\_ l/s of \_\_\_\_ from \_\_\_\_ °C to \_\_\_\_ °C when supplied with \_\_\_\_ l/s of condenser water at \_\_\_\_ °C. Steam consumption shall not exceed \_\_\_\_ kg/hr with an IPLV (APLV) of \_\_\_\_\_. The evaporator shall be selected for \_\_\_\_ m<sup>2</sup>K/kW fouling factor and maximum liquid pressure drop of \_\_\_\_ kPa. Waterside shall be designed for \_\_\_\_ barg working pressure. The refrigerant condenser shall be selected for \_\_\_\_ m<sup>2</sup>K/kW fouling factor and the steam condenser shall have a cleanliness factor of \_\_\_\_\_. The maximum refrigerant and steam condenser pressure drop shall be \_\_\_\_ kPa. Waterside shall be designed for \_\_\_\_ barg working pressure. Steam shall be supplied to the turbine at \_\_\_\_ barg and \_\_\_\_ °C.

Each unit shall be factory-packaged including evaporator, refrigerant condenser, sub-cooler, compressor, steam turbine, lubrication system, Power Panel, Programmable Control Center and all inter-connecting unit piping and wiring. A steam condenser shall be shipped separately and will be suitable for mounting on the refrigerant condenser. When specified, the steam condenser may be placed on the floor adjacent to the chiller (Customer to confirm which arrangement before the order is placed). The chiller shall be painted prior to shipment.

The initial charge of oil and refrigerant shall be supplied, shipped in containers and cylinders for field installation or factory charged in the chiller.

## POWER PANEL

All motor contactors and circuit protectors, the compressor oil pump variable speed drive and the control power

transformer shall be contained in an enclosure installed adjacent to the OptiView control center. A main power disconnect switch shall be supplied which provides the termination points for the customer's single point power supply wiring.

## PROGRAMMABLE CONTROL CENTER

The Programmable Control Center shall be factory-mounted, wired and tested microprocessor based control system for R134a centrifugal chillers. The panel shall be configured with a 10.4" diagonal color Liquid Crystal Display (LCD) surrounded by "soft" keys, which are redefined with one keystroke based on the screen displayed at that time.

The LCD display shall provide a graphical and animated display of the chiller, chiller sub-systems and system parameters, allowing the presentation of several operating parameters at once. A Status Bar shall be displayed at all times on all screens containing the System - Status Line and Details Line, the Control Source, Access Level, Time and Date.

During turbine slow roll, startup, operation and coast-down, the system status shall indicate vital information available at any time. Data shall be displayed in either English or SI units.

Security access shall be provided to prevent unauthorized changes of setpoints. There must be different levels of access including a servicing level which shall provide diagnostics and troubleshooting information for the chiller and panel. Password protection shall be provided for all access levels.

The control center power supply is provided from a fused 2KVA transformer located in the power panel.

The control center is also fused to provide individual over-current protected power for the remote mounted water pump motor starters (supplied by others) and the controls installed on the chiller. Numbered terminal strips for wiring such as Remote Start / Stop, Chilled Water Pump and Local or Remote Cycling devices shall be provided. The Panel must also provide field interlocks that indicate the chiller status. These contacts shall include a Remote Mode Ready-to-Start, a Controlled Shutdown, a Safety Shutdown and a chiller Run contact. System pressures shall be monitored with transmitters (4-20 mA) and transducers (0-5 VDC). System temperatures shall be monitored using thermistors and RTD's.

Setpoints can be changeable from a remote location via 0-10VDC and 4-20mA, contact closures or through serial communications. Serial data interface to the Building Automation System (BAS) shall be through an optional

Microgateway Card that can be mounted inside the Control Center.

The operating program shall be stored in non-volatile memory to eliminate chiller failure due to AC power failure/battery discharge. Programmed setpoints shall be retained in lithium battery-backed RTC memory for 11 years minimum.

Control system shall allow the chiller to operate at 36°F (2.2°C) leaving chilled water temperature without nuisance trips on low water temperature by monitoring the chiller water and evaporator refrigerant liquid temperatures to prevent freeze up.

Every programmable point shall have a pop-up screen with the allowable ranges, so that the chiller can not be programmed to operate outside of its design limits.

The capacity control logic shall provide stable operation at maximum efficiency at off design conditions by modulating the turbine speed, compressor pre-rotation vanes and hot gas by-pass valve.

When the power is applied to the chiller, the HOME screen shall be displayed. The HOME screen shall display a visual representation of the chiller and a collection of data detailing important operations and parameters. The primary values that need to be monitored and controlled shall be shown on this screen.

### **CAPACITY CONTROL**

The chiller shall be designed to operate with capacities from 100% to 10% of design capacity.

### **HOT GAS BY-PASS**

The chiller shall be equipped with an external, hot gas by-pass valve providing operational capability for part loads down to 10% of design. Hot gas by-pass valve shall have an electric actuator and shall be automatically controlled by the chiller micropanel to open only when stable chiller operation cannot be maintained through speed reduction and PRV closure alone.

### **COMPRESSOR**

The compressor shall be a single-stage centrifugal type driven by a condensing steam turbine. The housing shall be fully accessible with vertical circular joints, with the complete operating assembly removable from the compressor and scroll housing. Compressor castings shall be designed for a minimum 200 psig (1379 kPa) working pressure and hydrostatically pressure tested at a minimum of 300 psig (2070 kPa). The rotor assembly shall consist of a heat-treated alloy steel drive shaft and

impeller shaft with a cast aluminum, fully shrouded impeller. The impeller shall be designed for balanced thrust, dynamically balanced and overspeed tested for smooth, vibration-free operation. Insert-type journal and thrust bearings shall be fabricated of aluminum alloy, precision bored and axially grooved.

Internal single helical gears with crowned teeth shall be designed so that more than one tooth is in contact at all times to provide even load distribution and quiet operation. Each gear shall be individually mounted in its own journal and thrust bearings to isolate it from impeller and turbine forces. Shaft seal shall be provided in double bellows, double-seal, cartridge type. Capacity control shall be achieved by use of pre-rotation vanes and speed control to provide fully modulating control from full load to minimum load for maximum energy efficiency. Control shall automatically compensate for adverse operating conditions, such as fouled tubes, and adjust to prior operation after correction of these conditions.

The unit shall be capable of continuous, reliable operation with low ECWT at all load conditions as outlined on the equipment schedule. An external, electric actuator shall automatically control pre-rotation vane position.

### **COMPRESSOR LUBRICATION SYSTEM**

Lubrication oil shall be force-fed to all compressor bearings, gears, and rotating surfaces by an external variable speed oil pump. The oil pump shall vary oil flow to the compressor based on operating and stand-by conditions, ensuring adequate lubrication at all times. The oil pump shall operate prior to start-up, during compressor operation and during coastdown. Compressor shall have an internal, auxiliary reservoir at the top of the compressor housing to provide gravity fed lubrication during coastdown in the event of a power failure.

An oil reservoir, separate from the compressor, shall contain the submersible 2 HP oil pump and a 3000 watt oil heater, thermostatically controlled to remove refrigerant from the oil.

Oil shall be filtered by an externally mounted 1/2 micron replaceable cartridge oil filter equipped with service valves. Oil shall be cooled via a shell and tube, water cooled oil cooler sized to use refrigerant entering condenser water. The oil side of the oil cooler shall be provided with service valves and an Amot three way temperature control valve. Oil piping shall be completely factory-installed. The water side of the oil cooler shall be provided with service valves, inlet strainer and solenoid valve for automatic start/stop of cooling water flow. Water piping shall be factory installed with connections brought to the edge of the chiller package and clearly tagged for installation. An automatic oil return system shall be provided to recover any oil that may have

migrated to the evaporator.

## STEAM TURBINE DRIVELINE

### Steam Turbine Package

The steam turbine shall be of a high efficiency multistage design operating at a nominal 4500 rpm design maximum speed.

The turbine shall be packaged on a driveline base, completely factory piped. The driveline base shall have a mating flange on shaft end of the package that will bolt directly to the compressor D-flange face providing a rigid interface between turbine package and compressor. Complete turbine/compressor driveline shall be factory aligned prior to shipment. Turbine drive shaft shall be directly connected to the compressor shaft with a flexible disc coupling. Coupling shall have all metal construction with no wearing parts to assure long life, and no lubrication requirements to provide low maintenance.

The turbine casing shall be horizontally split designed to allow longitudinal thermal expansion without affecting alignment or efficiency of the turbine. The shaft and wheels shall be alloy steel with the wheels shrunk and keyed to the shaft. The turbine blades shall be of 403 grade stainless steel and the shaft shall be ground throughout with stainless steel sprayed in the carbon ring end gland contact area. Stainless steel nozzles shall be furnished throughout the turbine. Carbon ring end gland and diaphragm seals shall be furnished. Turbine end gland carbon ring seals (minimum five seals per end gland) shall be separated by partitions of stainless steel. The end gland seals are to be arranged for the admission of sealing steam. Pressure reducing valves shall be provided to regulate the steam pressure from steam inlet pressure to the 1-3 psig (7 - 21 kPa) needed for the gland seal.

A stainless steel, inlet steam strainer with adequate size and mesh to minimize the pressure drop shall be supplied. Strainer shall be removable without breaking the steam piping connections.

A fiberglass insulating blanket shall be provided on the steam chest and barrel of the turbine for operator protection.

The turbine speed control shall be achieved by a governor valve that is integrated with the chiller controls. The valve shall be of stainless steel with stainless steel seats and designed to control flow throughout the entire operating range of the turbine. The system shall employ an overspeed governor designed to close an independent high performance butterfly trip valve with a pneumatic actuator when the turbine speed exceeds 110 percent of the maximum continuous operating speed of the turbine. Activation of the independent trip valve shall cause the

governor valve to also close. A micro switch shall be furnished on the trip linkage for the customer's use.

## TURBINE LUBRICATION SYSTEMS

### Ring Oil Lubricated Turbines - Drive powers less than 1700Hp (1268 kW) only

The bearings shall be steel backed, babbitt lined, split sleeve type. The design shall be such that the bottom half is removable with the shaft in place. The bearing housing shall have provisions for air purging of the housing shaft seals. The thrust bearing shall be an antifriction ball bearing, accessible and removable without lifting the top half of the turbine casing. Oil cooling with water cooled bearing housings shall be provided.

### External, Pressurized Lube System Turbines

The bearings shall be steel backed, babbitt lined, split sleeve type. The design shall be such that the bottom half is removable with the shaft in place. The bearing housing shall have provisions for air purging of the housing shaft seals. The thrust bearing shall be a double acting, Kingsbury type. The lubrication system shall be integral to the turbine driveline base and completely factory piped. The lubrication system shall consist of a turbine shaft driven main oil pump, motor driven auxiliary oil pump, water cooled shell and tube oil cooler, 25 micron full flow oil filter and separate oil reservoir with level gauge. Oil temperature control shall be by Amot three way temperature control valve.

## STEAM CONDENSER PACKAGE

A steam condenser shall be provided to condense exhaust steam at vacuum pressures to maintain efficient turbine operation. The steam condenser water circuit shall be piped in series with the refrigerant condenser, eliminating a separate cooling water circuit and shall be designed to minimize pressure drop for energy savings.

The steam condenser shall be furnished fully packaged. The package shall include a single 5 HP hotwell pump, a single 7.5 HP liquid ring vacuum pump for air removal, atmospheric relief valve and level control system. The package shall be factory piped, wired and mounted on a common structural steel frame suitable for installation on the refrigerant condenser or floor mounting adjacent to the chiller system.

Steam condenser construction shall be of the shell and tube type of welded steel construction with 3/4" OD (19 mm) prime surface copper tubes, roller-expanded into tube sheets. Water side shall be suitable for a maximum working pressure of 150 psig (1030 kPa). Steam side shall be designed for 15 psig (100 kPa) and 30" Hg vac (760 mmHg). Water boxes shall be welded steel with removable covers. Condensate level shall be controlled

by a level control system with two (2) pneumatic control valves - one for re-circulation and the other for removal of condensate. The liquid ring vacuum pump shall be capable of drawing the condenser down to operating pressure in approximately 10 minutes. Hotwell pump shall be single-stage, end suction suitable for hotwell service.

Atmospheric relief valve shall be a water seal type with external handwheel, sized in accordance with the Heat Exchange Institute Standards (HEI) for protection of the steam turbine exhaust, steam trunk and steam condenser.

All key control and monitoring parameters shall be integral to the chiller control panel. In addition, auxiliary pressure gauges shall be located at the condenser steam inlet and condensate pump discharge piping, and temperature gauges shall be located at the steam inlet, cooling water inlet and outlet, and the hotwell.

To facilitate rigging, condenser shall be separable from the skid by unbolting. Insofar as practical, piping shall be outfitted with unions at reasonable break-points. Both condenser and skid shall be outfitted with lifting lugs for both vertical and horizontal lifting.

## EVAPORATOR

Evaporator shall be of the shell-and-tube, flooded type designed for a minimum of 180 psig (1241 kPa); working pressure on the refrigerant side. Shell shall be fabricated from rolled carbon steel plates with fusion welded seams, carbon steel tube sheets, drilled and reamed to accommodate the tubes, and intermediate tube supports spaced no more than four feet apart. The refrigerant side of each shell is designed, tested and stamped in accordance with ASME Boiler and Pressure Vessel Code, Section VIII - Division I, or other pressure vessel code as appropriate.

Heat exchanger tubes shall be high-efficiency, externally and internally enhanced type. Tubes shall utilize the "skip-fin" design, providing a smooth internal and external surface at each intermediate tube support. This provides extra wall thickness and non-work hardened copper at the support location, extending the life of the heat exchangers. If skip-fin tubes are not used, minimum tube wall thickness shall be 0.035" (0.889 mm). Each tube shall be roller expanded into the tube sheets providing a leak-proof seal, and be individually replaceable. Water velocity through the tubes shall not exceed 12 ft./sec. (3.7 m/s). A liquid level sight glass shall be provided on the side of the shell to aid in determining proper refrigerant charge and to check condition of the refrigerant charge. A suction baffle or aluminum mesh eliminators shall be located above the tube bundle to prevent liquid refrigerant carryover to the

compressor. The evaporator shall have a refrigerant relief device sized to meet the requirements of the ASHRAE 15 Safety Code for Mechanical Refrigeration.

Water boxes shall be removable to permit tube cleaning and replacement. Stub-out water connections having Victaulic grooves shall be provided.

Water boxes shall be designed for 150 psig (1030 kPa) design working pressure and be tested at 225 psig (1550 kPa). Vent and drain connections with plugs shall be provided on each water box.

(Option) The water boxes shall be suitable for 300 psig (2070 kPa) and be tested at 450 psig (3103 kPa). Vent and drain connections with plugs shall be provided on each water box.

## REFRIGERANT CONDENSER

Refrigerant condenser shall be of the shell-and-tube type, designed for a minimum of 235 psig (1620 kPa) working pressure on the refrigerant side. Shell shall be fabricated from rolled carbon steel plates with fusion welded seams. Carbon steel tube sheets, drilled and reamed to accommodate the tubes, are welded to the end of each shell. Intermediate tube supports are drilled and reamed to eliminate sharp edges, fabricated from carbon steel plates. The refrigerant side of each shell is designed, tested and stamped in accordance with ASME Boiler and Pressure Vessel Code, Section VIII - Division I, or other pressure vessel code as appropriate.

Heat exchanger tubes shall be high efficiency, externally and internally enhanced type. Tubes shall utilize the "skip-fin" design, providing a smooth internal and external surface at each intermediate tube support. This provides extra wall thickness and non-work hardened copper at the support location, extending the life of the heat exchangers. If skip-fin tubes are not used, minimum tube wall thickness shall be 0.035" (0.889 mm). Each tube shall be roller expanded into the tube sheets providing a leak-proof seal, and be individually replaceable. Water velocity through the tubes shall not exceed 12 ft/sec (3.7 m/s). A liquid level sight glass shall be provided on the side of the shell to aid in determining proper refrigerant charge and to check condition of the refrigerant charge. The refrigerant condenser shall have dual refrigerant relief devices; each sized to meet the requirements of the ASHRAE 15 Safety Code for Mechanical Refrigeration. Arrangement shall allow either valve to be isolated and replaced without removing the unit refrigerant charge.

(Option) The refrigerant condenser shall be provided with positive shutoff valves in the compressor discharge line and in the liquid line leaving the condenser. This will allow

---

pump down and storage of the refrigerant charge in the refrigerant condenser.

Water boxes shall be removable to permit tube cleaning and replacement. Stubout water connections having Victaulic grooves shall be provided. Water boxes shall be designed for 150 psig (1030 kPa) design working pressure and be tested at 225 psig (1550 kPa). Vent and drain connections with plugs shall be provided on each water box.

### **REFRIGERANT FLOW CONTROL**

A variable orifice valve shall control refrigerant flow to the evaporator. This valve control shall automatically adjust to maintain proper refrigerant level in the refrigerant condenser and shall be controlled by monitoring refrigerant liquid level, assuring optimal subcooler performance.

### **PORTABLE REFRIGERANT STORAGE RECYCLING SYSTEM**

A portable, self-contained refrigerant storage / recycling system shall be provided consisting of a refrigerant compressor with oil separator, storage receiver, water-cooled condenser, filter drier and necessary valves and hoses to remove, replace and distill refrigerant. All necessary controls and safety devices shall be a permanent part of the system.

### **START-UP AND OPERATOR TRAINING**

The chiller manufacturer shall include the services of a factory-trained, field service representative to supervise the final leak testing, charging and the initial startup and concurrent operator instruction.



# SI Metric Conversion

Values provided in this manual are in the English inch-pound (I-P) system.  
The following factors can be used to convert from English to the most common SI Metric values.

MEASUREMENT	MULTIPLY THIS ENGLISH VALUE	BY	TO OBTAIN THIS METRIC VALUE
CAPACITY	TONS REFRIGERANT EFFECT (ton)	3.516	KILOWATTS (kW)
POWER	KILOWATTS (kW)	NO CHANGE	KILOWATTS (kW)
	HORSEPOWER (hp)	0.7457	KILOWATTS (kW)
FLOW RATE	GALLONS / MINUTE (gpm)	0.0631	LITERS / SECOND (L/s)
LENGTH	FEET (ft)	304.8	MILLIMETERS (mm)
	INCHES (in)	25.4	MILLIMETERS (mm)
WEIGHT	POUNDS (lb)	0.4536	KILOGRAMS (kg)
VELOCITY	FEET / SECOND (fps)	0.3048	METERS / SECOND (m/s)
PRESSURE DROP	FEET OF WATER (ft)	2.989	KILOPASCALS (k Pa)
	POUNDS / SQ. INCH (psi)	6.895	KILOPASCALS (k Pa)

## TEMPERATURE

To convert degrees Fahrenheit (°F) to degrees Celsius (°C), subtract 32° and multiply by 5/9 or 0.5556.

To convert a temperature range (i.e., 10°F or 12°F chilled water range) from Fahrenheit to Celsius, multiply by 5/9 or 0.5556.

## EFFICIENCY

In the English I-P system, chiller efficiency is measured in kW / ton:

$$\text{kW / ton} = \frac{\text{kW input}}{\text{tons refrigerant effect}}$$

In the SI Metric system, chiller efficiency is measured in Coefficient of Performance (COP).

$$\text{COP} = \frac{\text{kW refrigeration effect}}{\text{kW input}}$$

kW / ton and COP are related as follows:

$$\text{kW/ton} = \frac{3.516}{\text{COP}}$$

$$\text{COP} = \frac{3.516}{\text{kW/ton}}$$

## FOULING FACTOR

ENGLISH I-P (ft <sup>2</sup> °F hr/Btu)	EQUIVALENT SI METRIC (m <sup>2</sup> k/kW)
0.0001	.018
0.00025	.044
0.0005	.088
0.00075	.132

For Steam systems (I-P system):

$$\text{COP} = \frac{\text{Refrigeration effect (Btu/hr)}}{\text{Steam flow (lb/hr) x (Steam supply (Btu/lb) - condensate return (Btu/lb))}}$$

For Steam systems (SI system):

$$\text{COP} = \frac{\text{Refrigeration effect (kW)}}{\text{Steam flow (kg/s) x (Steam supply (kJ/kg) - condensate return (kJ/kg))}}$$

