

DIMENSIONS: MSZ-A09NA & MUZ-A09NA

MSZ-A09NA

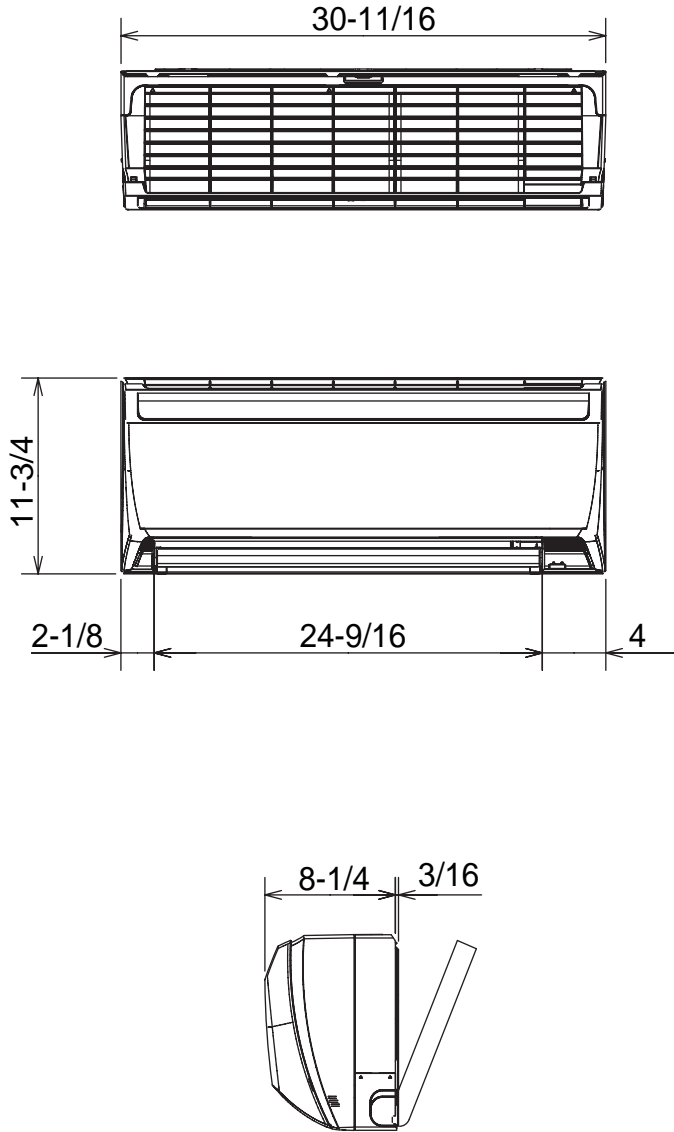

MUZ-A09NA

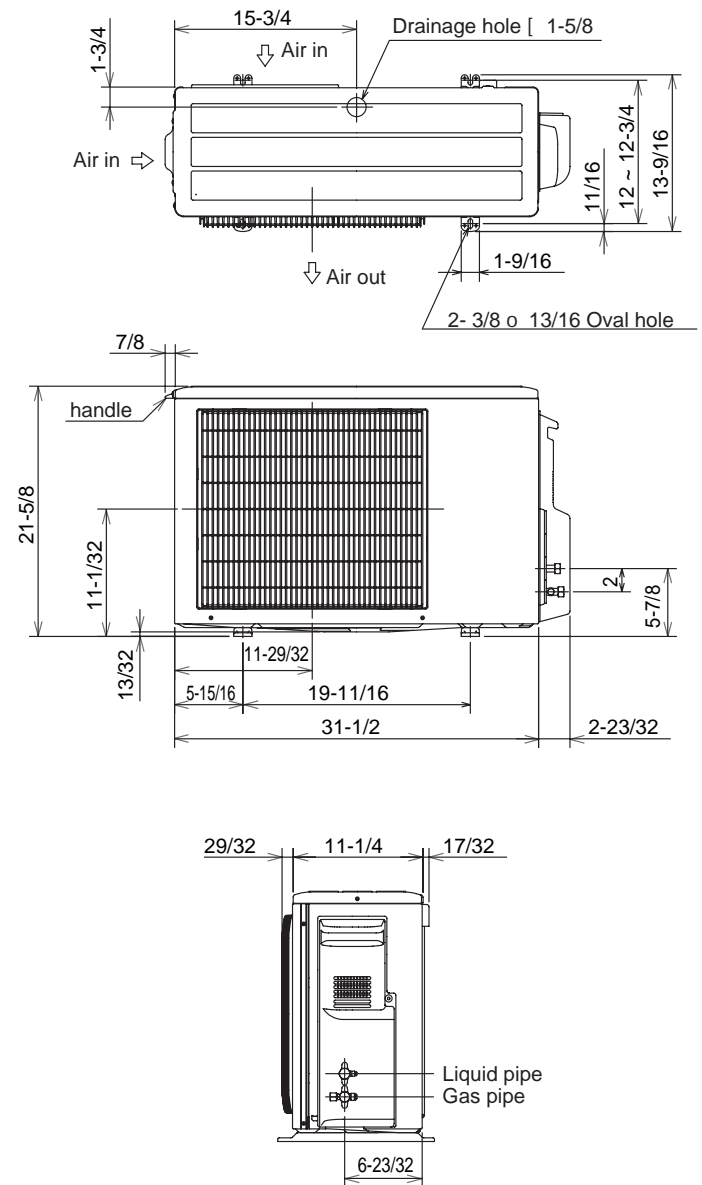

HVAC Advanced Products Division
Mitsubishi Electric & Electronics USA, Inc.

3400 Lawrenceville Suwanee Rd
Suwanee, GA 30024
Tele: 678-376-2900 • Fax: 800-889-9904
Toll Free: 800-433-4822 (#3)
www.mehvac.com