



LATITUDE™
Air Cooled Screw Liquid Chillers
STYLE A



ARI Standard
550/590 AC
140-200 Tons
60Hz

R134a

150 -385 TONS & 385 - 515 TONS
527 - 1354 kW & 1354 - 1804 kW
60 Hz 50 & 60 Hz

ASHRAE 90.1 Compliant



TABLE OF CONTENTS

Introduction	3
Specifications	4
Accessories and Options	7
Nomenclature	9
Temperatures and Flows	10
Water Pressure Drop	12
Efficiency	16
Standard Efficiency Ratings – English - 60Hz	18
High Efficiency Ratings – English - 60Hz	30
Standard Efficiency Ratings – SI - 60Hz	40
High Efficiency Ratings – SI - 60Hz	46
Standard Efficiency Ratings – SI - 50Hz	52
High Efficiency Ratings – SI - 50Hz	54
Physical Data (English - Standard Efficiency)	56
Physical Data (English - High Efficiency)	57
Physical Data (SI - Standard Efficiency)	60
Physical Data (SI - High Efficiency)	61
Dimensions – English	64
Dimensions – English	70
Dimensions – SI	96
Isolator Details	128
Electrical Data - 2 Comp - 60Hz	132
Electrical Data - 3 Comp - 60Hz	136
Electrical Data - 4 Comp - 60Hz	138
Electrical Data - 4 Comp - 50Hz	142
Electrical Notes	144
Power Wiring	145
Typical Control Wiring - Two Compressor	150
Typical Control Wiring - Three Compressor	152
Typical Control Wiring - Four Compressor	154
Application Data	156
Guide Specifications	157

YORK YCAV Air Cooled Screw Liquid Chillers



YORK has a proud history of innovation in both compressor design and variable speed drive (VSD) technology. The Latitude™ air cooled chiller uses the best of modern screw compressor design and manufacturing techniques and combines them with the latest in a long line of chiller variable speed drives. The result is superior control and industry leading efficiency at real world conditions. In addition, by slowing the speed of the chiller to match system requirements at off-design conditions, the chiller sound output is reduced when it is the most sensitive to neighbors – evenings and weekends.

With the introduction of the YCAV model air cooled chiller, system designers are given the Latitude™ to design around the traditional benefits of air cooled chillers and still offer building owners energy efficient system design. In the past, the choice to use an air cooled chiller came with the expectation of compromise, where simplicity of design and maintenance were traded for performance and efficiency. Now combining the best of both worlds can provide a design that truly delivers the lowest total cost of ownership.

Specifications

POWER AND ELECTRICAL

- **YORK** has over 25 years of experience designing variable speed drives specifically for chiller applications. The result is an extremely reliable air cooled chiller system that offers industry leading efficiency at real world operating conditions, valve-less compressor loading/unloading, excellent capacity control, high power factor and soft start.
- VSD Power/Control Panel includes main power connection(s), VSD and fan motor contactors, current overloads, and factory wiring. Standard design includes NEMA 3R (IP14) rating, powder painted steel cabinet with hinged, latched, and gasket sealed outer doors equipped with wind struts for safer servicing.
- VSD section of power panel includes a dedicated inverter for each compressor.
- The panel includes control display access door so display and control features can be accessed without opening main cabinet doors.
- Two and three compressor models come standard with single point power connection. Four compressor models have multi-point power connections as standard. In addition, all models are supplied with a factory mounted and wired control transformer that will supply all unit control voltage from the main unit power supply. The transformer utilizes scheduled line voltage on the primary side and provides 115V/1Ø on secondary.
- Short Circuit Withstand Rating of the chiller electrical enclosure is 30,000 Amps for standard terminal block connection. Ratings in accordance with UL508. (See Accessories and Options section: Can be increased to 200V & 230V: 100,000 Amps, 380 & 460V: 65,000 Amps, 575V: 42,000 Amps).
- Motors are powered by a variable speed drive. Therefore, motor current never exceeds the rated load amps (RLA), providing soft starts with no electrical inrush. This eliminates the motor heating and stress always found with conventional motor starters. In addition, by eliminating the heat build up during starting, the required off-time between starts is reduced to a maximum of two minutes.
- The U.S. Department of Energy (D.O.E.) states that many utility companies charge an additional fee if power factor is below 0.95. These power factor adjustments/penalties can affect both regular tariff rates, as well as demand charges. All YCAV models have a full load power factor of 95% and maintain this level throughout the operating range. Specifications should always require the installing contractor to be responsible for additional cost to furnish and install power factor correction capacitors if they are not factory mounted and wired.

SEMI-HERMETIC YORK TWIN SCREW COMPRESSORS

An ideal synergy of expertise, sister division YORK Refrigeration's compressor engineers, as integral members on YORK Engineered Systems' Chiller Design Team, has developed a world class compressor with unequaled performance:

- Continuous function, microprocessor controlled, VSD provides valveless, smooth capacity control from 100% down to 10% of chiller capacity for two compressor chillers, 100% down to 7.5% for three compressor chillers, and 100% down to 5% in four compressor chillers. In addition, elimination of the slide valve and associated unloading components resulted in a 50% reduction in compressor moving parts.
- Compressors are direct drive, semihermetic, rotary twin-screw type, including: muffler, temperature actuated 'off-cycle' heater, rain-tight terminal box, discharge shut-off service valve, and precision machined cast iron housing mounted on neoprene isolators.
- Reliable suction gas cooled, high efficiency, accessible hermetic compressor motor, full suction gas flow through 0.006" maximum mesh screen, with inherent internal thermal overload protection and external current overload on all three phases.
- Suction gas screen and serviceable, 0.5 micron full flow oil filter within the compressor housing.
- Cast iron compressor housing precisely machined for optimal clearances and superb efficiency. Entire compressor, from suction to discharge has a Design Working Pressure of 380 PSIG (26 bar) or higher.

REFRIGERANT CIRCUIT

- Independent refrigerant circuits per compressor, each using copper refrigerant pipe formed on computer controlled bending machines. This eliminates over 60% of system piping brazed joints as compared to designs that use fittings, resulting in a highly reliable and leak resistant system.
- Liquid line components include: liquid line shut-off valve with charging port, low side pressure relief device, high adsorption removable core filter-drier, sight glass with moisture-indicator, and electronic expansion valve.
- Discharge line provided with manual compressor shutoff service valve (See Options and Accessories for suction line valve). Suction line equipped with closed-cell insulation.
- External oil separators with no moving parts, 450 PSIG (31 bar) design working pressure, and UL listing. Refrigerant system differential pressure provides oil flow through service replaceable, 0.5 micron, full

flow, cartridge type oil filter internal to compressor.

- Oil cooling provided by dedicated air cooled finned tube type heat exchanger located in the condenser section of the machine.

EVAPORATOR

- High efficiency, direct-expansion type cooler with refrigerant in tubes and chilled liquid through the baffled shell. Independent circuits provided for each compressor.
- Design working pressure of the shell waterside is 150 PSIG (10.3 bar), and 235 PSIG (16 bar) for the refrigerant side. Constructed and tested in accordance with applicable sections of ASME Pressure Vessel Code, Section VIII, Division (1). Water side exempt per paragraph U-1, ©, (6).
- Removable heads allow access to internally-enhanced, seamless, copper tubes. Water vent and drain connections included.
- Cooler equipped with thermostatically controlled heater for protection to -20°F (-29°C) ambient, and shell is covered with 3/4" (19mm), flexible, closed-cell insulation, thermal conductivity of 0.26k (BTU/HR-Ft²-°F/in.) maximum.
- Water nozzles with grooves for mechanical couplings, and insulated by Contractor after pipe installation.

CONDENSER SECTION

- Low Sound Fans are provided standard on all models. Fans are dynamically and statically balanced, direct drive, corrosion resistant glass fiber reinforced composite blades molded into low noise, full airfoil cross section, providing vertical air discharge from extended orifices. Guards of heavy gauge, PVC (polyvinyl chloride) coated.
- Condenser fan motors are high efficiency, direct drive, 3-phase, Class-"F" insulation, current overload protected, totally enclosed (TEAO) type with double sealed, permanently lubricated, ball bearings.
- Fin and tube condenser coils of seamless, internally enhanced, high condensing coefficient, corrosion resistant copper tubes arranged in staggered rows and mechanically bonded to corrosion resistant aluminum alloy fins with full height fin collars. Design working pressure is 450 PSIG (31 bar).

MICROPROCESSOR CONTROLS

- Microprocessor control system provides automatic control of chiller operation including compressor start/stop and load/unload, anti-recycle timers, condenser fans, evaporator pump, evaporator heater, unit alarm contacts and run signal contacts.
- Chiller automatically resets to normal chiller operation

after power failure.

- Unit operating software is stored in non-volatile memory. Field programmed set points are retained in lithium battery backed real time clock (RTC) memory for minimum 5 years.
- Alarm contacts are provided to remote alert contacts for any unit or system safety fault.
- Display and Keypad:
 - ◆ 80 character liquid crystal display that is both viewable in direct sunlight and has LED backlighting for nighttime viewing. One keypad and display panel is provided with every chiller.
 - ◆ Display and keypad is accessible through display access door without opening main control/electrical cabinet doors.
 - ◆ Display provides unit setpoints, status, electrical data, temperature data, pressures, safety lock-outs and diagnostics without the use of a coded display.
 - ◆ Descriptions in English (or Spanish or French), numeric data in English (or Metric) units.
 - ◆ Sealed keypad shall include unit On/Off switch.
- Programmable Setpoints (within Manufacturer limits): display language; leaving chilled liquid temperature: setpoint, control range; local or remote control; units of measure; compressor lead/lag; and maximum chilled water setpoint reset temperature range.
- Display Data: Chiller liquid return and leaving temperatures, ambient, lead compressor identification, clock and schedule, (variable) out of range, remote input indication, chilled liquid reset setpoint, and history data for last ten shutdown faults. Compressor suction, discharge, and oil pressures and temperatures, suction and discharge superheats, percent of full-load, operating hours, starts, and anti-recycle timer status. Status Messages for manual override, unit switch off, compressor run, run permissive, remote controlled shut down, no cooling load, daily/holiday shut down, anti-recycle timer.
- During extreme or unusual conditions (i.e. blocked condenser coils, ambient above scheduled maximum, etc.) the chiller control system will avoid safety shutdown by varying the chiller controls and cooling load output to stay online and avoid safety limits being reached. This allows maximum possible cooling capacity until the unusual condition is cleared and avoids costly shutdowns. The system monitors the following parameters and maintain the maximum cooling output possible without shutdown of the equipment: motor current, suction pressure and discharge pressure.
- System Safeties are provided for individual compressor systems to perform auto-reset shut down (manual reset required after the third trip in 90 minutes). Safe-

Specifications – Continued

ties include: high discharge pressure or temperature, low suction pressure, high / low motor current, high motor temperature, high pressure switch, high / low differential oil pressure, high oil temperature, low suction superheat, critical sensor malfunction, low or high current, phase loss/single phase power, overload of motor windings, and low voltage.

- Unit Safeties are provided for the chiller to perform auto-reset shut down for the following conditions: high or low ambient, low leaving chilled liquid temperature, under voltage, and flow switch operation.

COMPLETE FACTORY PACKAGE

- These air cooled chillers are shipped as a complete factory package. Each unit is completely assembled with all interconnecting refrigerant piping and internal wiring, ready for field installation:
- Each compressor is installed on its own independent refrigerant circuit, which is factory pressure tested, evacuated, then fully charged with R134a refrigerant and oil.

- After assembly, an operational test is performed with water flowing through the cooler to ensure each circuit operates correctly.
- Unit panels, structural elements, control boxes and heavy gauge structural base shall be constructed of galvanized steel. Unit panels, control boxes and structural base are finished with a baked on powder paint. All painted surfaces shall be coated with baked on powder paint which, when subject to ASTM B117, 1,000 hour, 5% salt spray test, yields minimum ASTM 1654 rating of "6".
- Design is in accordance with applicable sections of ASME Pressure Vessel Code, NFPA 70 (National Electrical Code), U.L. and cU.L. Standards, and ASHRAE/ANSI-15 Safety Code for Mechanical Refrigeration.
- Units are Rated (all) and Certified (140 - 200 tons) in accordance with ARI Standard 550/590-98.
- All exposed power wiring routed through liquid-tight, UV-stabilized, non-metallic conduit.

SOUND REDUCTION OPTIONS – One or all options may be employed by the system designer as normally generated machine noise is considered in the overall project design:

SilentNight™ – Standard variable speed compressors result in a chiller system that has lower part load sound values than conventional air-cooled chillers. Over 99% of chiller operating hours occur when building loads are less than design and/or ambient temperatures are less than design. As a result, all YCAV model chillers will operate with less than full load sound output nearly all the time – this is especially important on evenings and weekends when neighbors are home the most. Due to time of day based sound regulations it may be desirable to force the chiller to a lower sound level on demand. The SilentNight™ control option provides a control input to limit sound output of the chiller based on time of day. This feature is programmable at the chiller panel or can be controlled remotely via signal (4-20mA or 0-10 VDC) from a BAS system.

Ultra Quiet Fans (Factory Mounted) – With this option, the basic chiller is equipped with specially designed fans and motors to provide lower sound levels and retain appropriate airflow. The result is reduced fan generated noise with no adverse effect on the chiller capacity or efficiency performance.

Compressor Sound Blankets (Factory Mounted) – Black, high strength, rip-resistant, two-piece acoustic compressor sound blanket. Material is both UV and mildew protected, waterproof and fire resistant (meeting California fire marshal flame specification).

Acoustical perimeter enclosures (Field Mounted) – Galvanized internal baffles are factory mounted inside of the condenser section. Perimeter enclosure panels that mount around the bottom section of the chiller to reduce sound output. Enclosures panels are painted to match unit panels and include sound insulating baffles spaced to allow for proper airflow. NOTE: The perimeter enclosures ship separately from unit (**Field Mounted**).

CIRCUIT BREAKER – Power panel will come equipped with a factory mounted circuit breaker at point of incoming single or multi-point connection that provides the following:

- Means to disconnect power mounted on chiller.
- Circuit breaker sized to provide the motor branch circuit protection, short circuit protection and ground fault protection for the motor branch-circuit conductors, the motor control apparatus and the motors. (Chiller mounted circuit breaker option sized for branch circuit protection eliminates the need to provide a separate 'line of sight' disconnect and separate branch circuit protection device.)
- Lockable operating handle that extends through power panel door so that power may be disconnected without

opening any panel doors.

- Short Circuit Withstand Rating of the chiller electrical enclosure when using circuit breaker option is (200V & 230V: 100,000 Amps, 380 & 460V: 65,000 Amps, 575V: 42,000 Amps). Rating in accordance with UL508.

CONDENSER COIL PROTECTION – Standard condenser coil construction materials include aluminum fins, copper tubes, and galvanized tube supports for generally good corrosion resistance. However, these materials are not adequate for all environments. The system designer can take steps to inhibit coil corrosion in harsh applications and enhance equipment life by choosing from these options based on project design parameters and related environmental factors. (**Factory Mounted**)

- **PRE-COATED FIN CONDENSER COILS** – The air cooled condenser coils are constructed of epoxy-coated aluminum fins. This can provide corrosion resistance comparable to copper-fin coils in typical seashore locations. Either these or the post coated coils (below), are recommended for units being installed at the seashore or where salt spray may hit the unit.
- **POST-COATED EPOXY DIPPED CONDENSER COILS** – The unit is built with dipped-cured epoxy condenser coils. This is another choice for seashore and other corrosive applications (with the exception of strong alkalis, oxidizers and wet bromine, chlorine and fluorine in concentrations greater than 100 ppm).
- **COPPER FIN CONDENSER COILS** – The unit constructed with copper tube condenser coils, which have copper fins. (This is not recommended for units in areas where they may be exposed to acid rain.)

PROTECTIVE CHILLER PANELS:

- **Wire Panels (full unit)** – UV stabilized black polyvinyl chloride coated, heavy gauge, welded wire mesh guards mounted on the exterior of the unit. Protects condenser coil faces and prevents unauthorized access to refrigerant components (compressors, pipes, cooler, etc.), yet provides free air flow. This can cut installation cost by eliminating the need for separate, expensive fencing. (**Factory mounted**)
- **Louvered Panels (condenser coils only)** – Painted steel to match unit panels, louvered panels are mounted over the exterior condenser coil faces on the sides of the unit to visually screen and protect coils. (**Factory mounted**)
- **Louvered Panels (full unit)** – Painted steel to match unit panels, to protect condenser coils from incidental damage, visually screen internal components, and

Accessories and Options – Continued

prevent unauthorized access to internal components. **(Factory mounted)**

- **Louvered (Condensers)/Wire Panels (Mechanical)** – Louvered steel panels on external condenser coil faces, painted to match unit panels. Heavy gauge, welded wire-mesh, coated to resist corrosion, around base of machine to restrict unauthorized access. **(Factory Mounted)**

EVAPORATOR OPTIONS:

- **1-1/2" Insulation** – Double thickness insulation provided. **(Factory Mounted)**
- **Raised Face Flange Accessory** for cooler nozzles:
 - ◆ 150 PSIG (10.3 bar), welded flanges (field kit, matching pipe flange by contractor).
 - ◆ 300 PSIG (20.7 bar), welded flanges (factory installed, matching pipe flange by contractor).
 - ◆ 150 PSIG (10.3 bar), Victaulic™ Flanges (field kit, matching pipe flange by contractor).

FLOW SWITCH ACCESSORY : Vapor proof SPDT, NEMA 3R switch, 150 PSIG (10.3 bar) DWP, 20°F to 250°F (-28.9°C to 121.1°C) with 1" NPT (IPS) connection for upright mounting in horizontal pipe (This flow switch or equivalent must be furnished with each unit). **(Field Mounted)**.

DIFFERENTIAL PRESSURE SWITCH - Alternative to the paddle-type flow switch. 3-45 PSIG (0.2-3 bar) range with 1/4" NPTE pressure connections. **(Field Mounted)**

BUILDING AUTOMATION SYSTEM INTERFACE:

- Chiller to accept 4 to 20mA or 0 to 10 VDC input to reset the leaving chilled liquid temperature, or percent full load amps (current limit). **(Factory Mounted)**

MULTI-UNIT SEQUENCE CONTROL:

Separate sequencing control center provided to permit control of up to eight chillers in parallel based of mixed liquid temperature (interconnecting wiring by others). **(Field Mounted)**

VIBRATION ISOLATION:

- **Neoprene Isolation** – Recommended for normal installations. Provides very good performance in most applications for the least cost. **(Field mounted)**
- **1" Spring Isolators** – Level adjustable, spring and cage type isolators for mounting under the unit base rails. 1" nominal deflection may vary slightly by application. **(Field mounted)**
- **2" Seismic Spring Isolators** – Restrained Spring-Flex Mountings incorporate a rugged welded steel housing with vertical and horizontal limit stops. Housings designed to withstand a minimum 1.0g accelerated force in all directions to 2". Level adjustable, deflection may vary slightly by application. **(Field mounted)**

BUY AMERICAN ACT COMPLIANCE - In keeping with the "Buy America Act", products will be comprised of 50% or more U.S. content and manufactured (final assembly) in the U.S.A.

SERVICE ISOLATION VALVE – Service suction isolation added to unit for each refrigerant circuit. **(Factory Mounted)**

CHICAGO CODE RELIEF VALVE - Special relief valves per Chicago code. **(Factory Mounted)**

SEQUENCE CONTROL AUTOMATIC LEAD TRANSFER

- Provided to permit control of up to eight chillers in parallel based on mixed liquid temperature **(Field Mounted)**

NOMENCLATURE

The Model Number denotes the following characteristics of the unit:

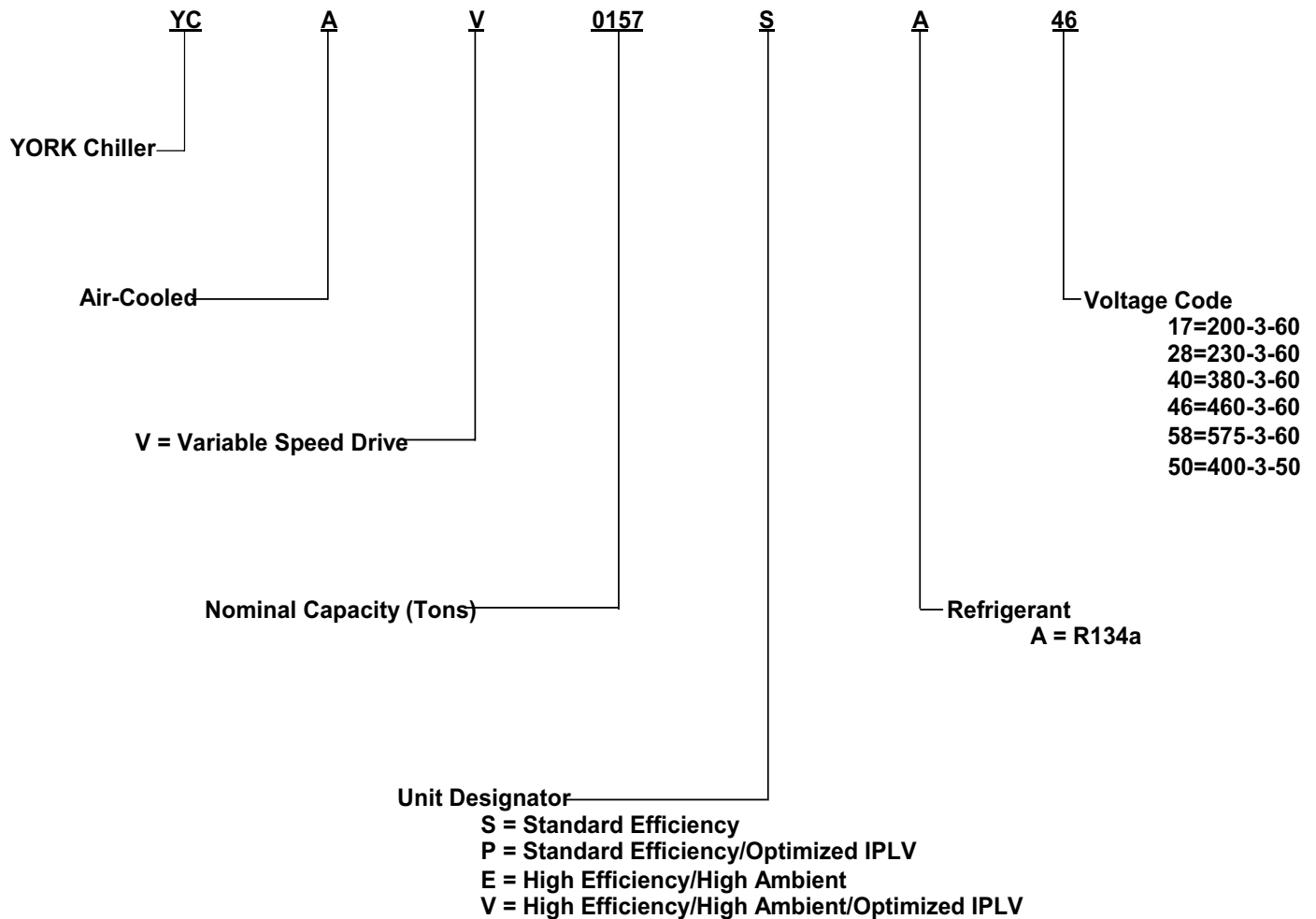

Temperatures and Flows

TEMPERATURE AND FLOWS (English Units)

MODEL NUMBER YCAV		LEAVING WATER TEMPERATURE (°F)		COOLER ³ FLOW (GPM)		AIR ON CONDENSER (°F)	
50HZ	60HZ	MIN. ¹	MAX. ²	MIN.	MAX.	MIN.	MAX
-	0157(S/P)	40	60	140	675	0	125
-	0157(E/V)	40	60	160	750	0	125
-	0177(S/P/E/V)	40	60	160	750	0	125
-	0187(S/P/E/V)	40	60	160	750	0	125
-	0197(E/V)	40	60	180	750	0	125
-	0207(S/P)	40	60	180	800	0	125
-	0207(E/V)	40	60	180	750	0	125
-	0227(S/P)	40	60	180	800	0	125
-	0227(E/V)	40	60	180	750	0	125
-	0247(S/P/E/V)	40	60	180	800	0	125
-	0267(S/P)	40	60	180	800	0	125
-	0267(E/V)	40	60	250	1200	0	125
-	0287(S/P/E/V)	40	60	250	1200	0	125
-	0307(S/P)	40	60	300	1200	0	125
-	0327(E/V)	40	60	300	1200	0	125
-	0357(S/P/E/V)	40	60	300	1200	0	125
-	0397(S/P)	40	60	300	1200	0	125
1429 (E/V)	0397(E/V)	40	60	350	1250	0	125
1549 (S/P)	0417(S/P)	40	60	350	1250	0	125
1549 (E/V)	0417(E/V)	40	60	400	1400	0	125
1649 (S/P)	0457(S/P)	40	60	350	1250	0	125
1739 (S/P/E/V)	0477(S/P/E/V)	40	60	400	1400	0	125
1829 (S/P)	0507(S/P)	40	60	400	1400	0	125
1909 (S/P)	0527(S/P)	40	60	400	1400	0	125

NOTES:

1. For leaving brine temperature below 40°F (4.4°C), contact your nearest YORK office for application requirements.
2. For leaving water temperature higher than 60°F (15.6°C), contact the nearest YORK office for application guidelines.
3. The evaporator is protected against freezing to -20°F (-28.8°C) with an electric heater as standard.

TEMPERATURE AND FLOWS (SI Units)

MODEL NUMBER YCAV		LEAVING WATER TEMPERATURE (°C)		COOLER ³ FLOW (l/s)		AIR ON CONDENSER (°C)	
50HZ	60HZ	MIN. ¹	MAX. ²	MIN.	MAX.	MIN.	MAX
-	0157(S/P)	4.4	15.6	8.8	42.6	-17.8	51.7
-	0157(E/V)	4.4	15.6	10.1	47.3	-17.8	51.7
-	0177(S/P/E/V)	4.4	15.6	10.1	47.3	-17.8	51.7
-	0187(S/P/E/V)	4.4	15.6	10.1	47.3	-17.8	51.7
-	0197(E/V)	4.4	15.6	11.4	47.3	-17.8	51.7
-	0207(S/P)	4.4	15.6	11.4	50.5	-17.8	51.7
-	0207(E/V)	4.4	15.6	11.4	47.3	-17.8	51.7
-	0227(S/P)	4.4	15.6	11.4	50.5	-17.8	51.7
-	0227(E/V)	4.4	15.6	11.4	47.3	-17.8	51.7
-	0247(S/P/E/V)	4.4	15.6	11.4	50.5	-17.8	51.7
-	0267(S/P)	4.4	15.6	11.4	50.5	-17.8	51.7
-	0267(E/V)	4.4	15.6	15.8	75.7	-17.8	51.7
-	0287(S/P/E/V)	4.4	15.6	15.8	75.7	-17.8	51.7
-	0307(S/P)	4.4	15.6	18.9	75.7	-17.8	51.7
-	0327(E/V)	4.4	15.6	18.9	75.7	-17.8	51.7
-	0357(S/P/E/V)	4.4	15.6	18.9	75.7	-17.8	51.7
-	0397(S/P)	4.4	15.6	18.9	75.7	-17.8	51.7
1429 (E/V)	0397(E/V)	4.4	15.6	22.1	78.9	-17.8	51.7
1549 (S/P)	0417(S/P)	4.4	15.6	22.1	78.9	-17.8	51.7
1549 (E/V)	0417(E/V)	4.4	15.6	25.2	88.3	-17.8	51.7
1649 (S/P)	0457(S/P)	4.4	15.6	22.1	78.9	-17.8	51.7
1739 (S/P/E/V)	0477(S/P/E/V)	4.4	15.6	25.2	88.3	-17.8	51.7
1829 (S/P)	0507(S/P)	4.4	15.6	25.2	88.3	-17.8	51.7
1909 (S/P)	0527(S/P)	4.4	15.6	25.2	88.3	-17.8	51.7

NOTES:

1. For leaving brine temperature below 4.4°C, contact your nearest YORK office for application requirements.
2. For leaving water temperature higher than 15.6°C, contact the nearest YORK office for application guidelines.
3. The evaporator is protected against freezing to -28.8°C with an electric heater as standard.

Water Pressure Drop

ENGLISH UNITS

Pressure Drop Through Two Circuit YCAV Evaporators

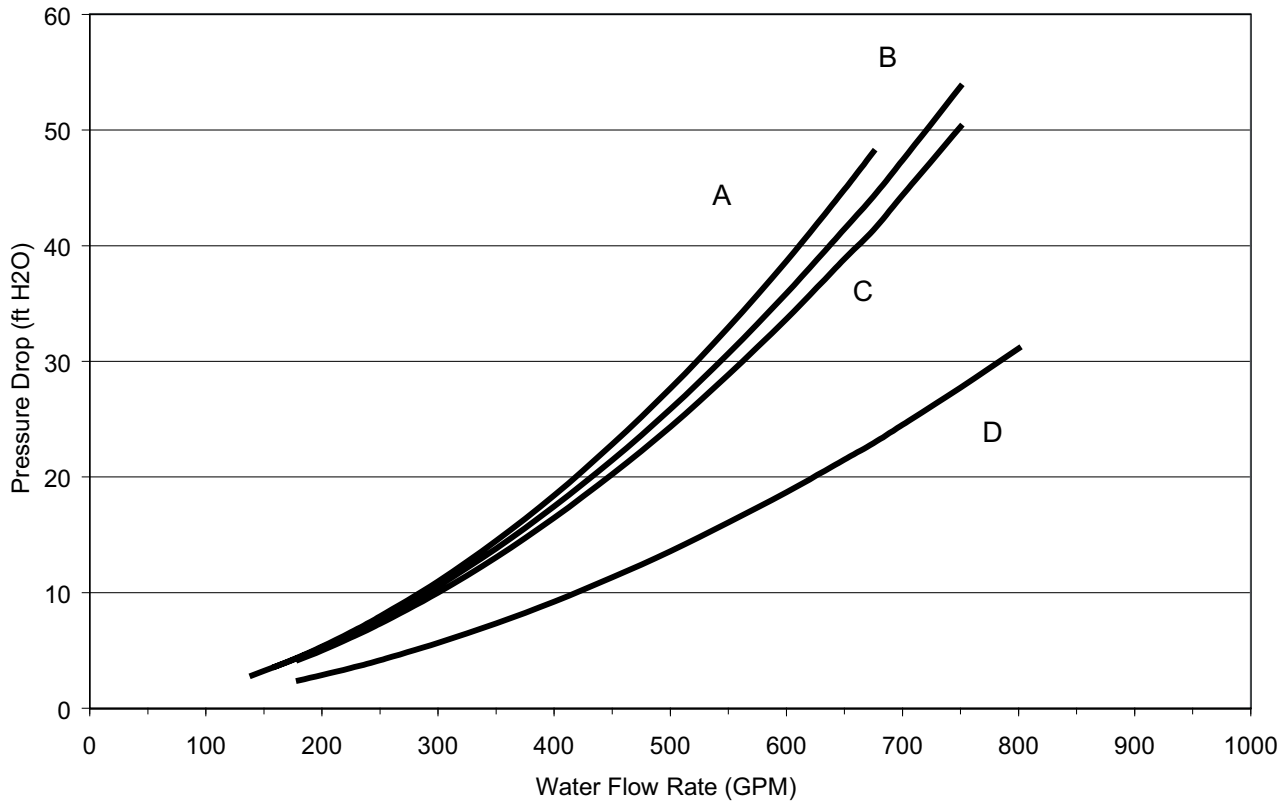

COOLER	MODEL NUMBER YCAV
A	0157(S/P)
	0157(E/V)
B	0177(S/P/E/V)
	0187(S/P/E/V)
C	0197(E/V)
	0207(E/V)
	0227(E/V)
D	0207(S/P)
	0227(S/P)
	0247(S/P/E/V)
	0267(S/P)

SI UNITS

Pressure Drop Through Two Circuit YCAV Evaporators

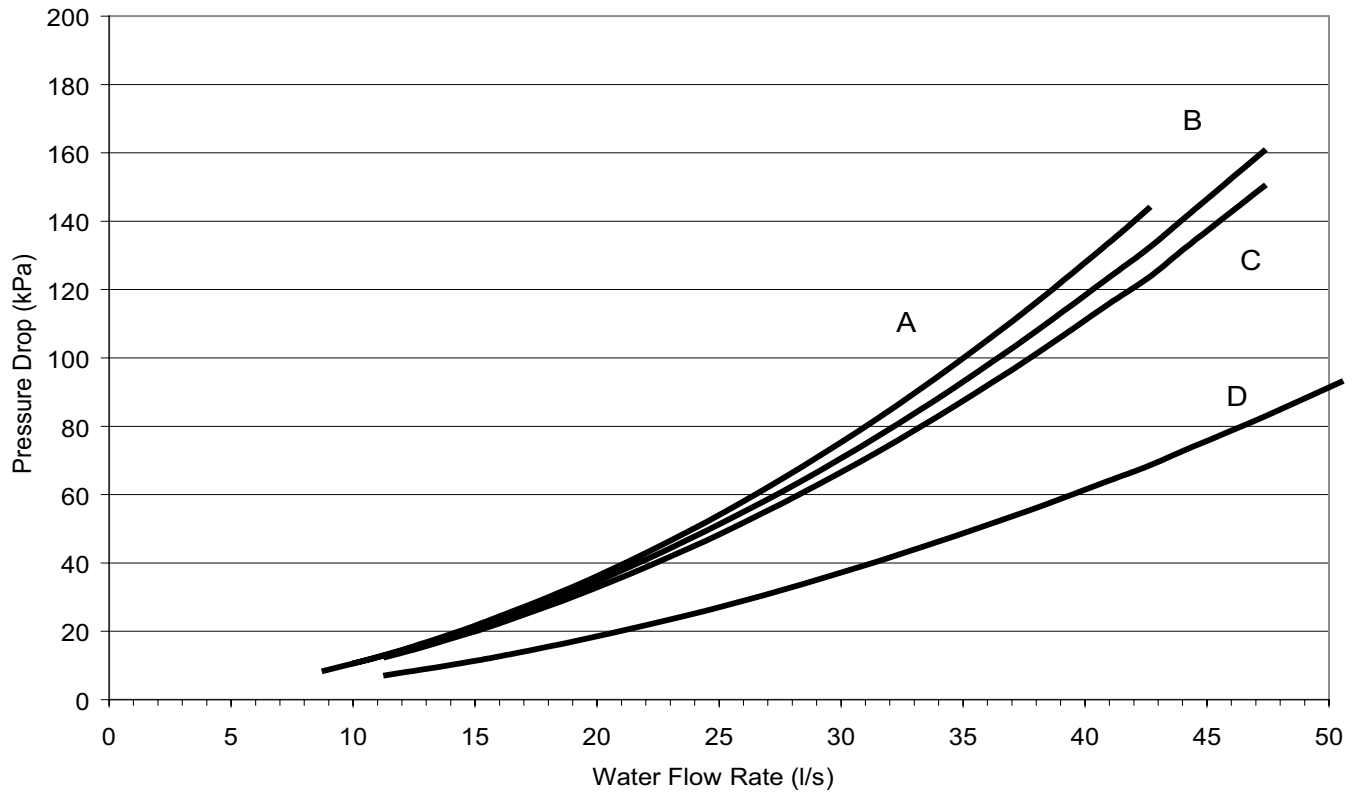

COOLER	MODEL NUMBER YCAV
A	0157(S/P)
	0157(E/V)
B	0177(S/P/E/V)
	0187(S/P/E/V)
C	0197(E/V)
	0207(E/V)
	0227(E/V)
D	0207(S/P)
	0227(S/P)
	0247(S/P/E/V)
	0267(S/P)

Water Pressure Drop

Pressure Drop Through Three and Four Circuit YCAV Evaporator

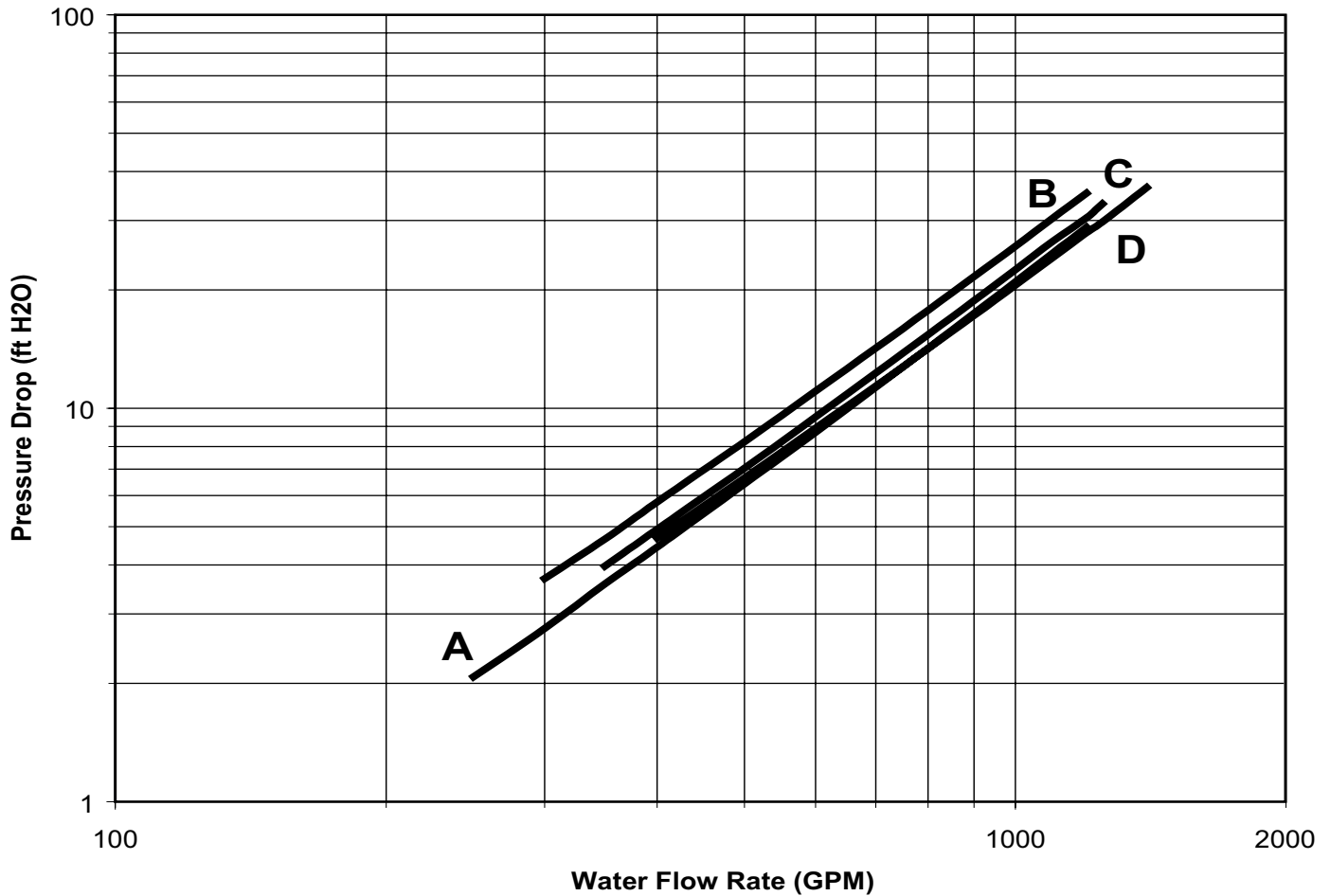

EVAP	YCAV MODELS	
	50Hz	60Hz
A	-	0267EA/VA
	-	0287SA/PA
	-	0287EA/VA
B	-	0307SA/PA
	-	0327EA/VA
	-	0357SA/PA
	-	0357EA/VA
	-	0397SA/PA
C	1429 EA/VA	0397EA/VA
	1549 SA/PA	0417SA/PA
	1649 SA/PA	0457SA/PA
D	1549 EA/VA	0417EA/VA
	1739 SA/PA	0477EA/VA
	1739 EA/VA	0477SA/PA
	1829 SA/PA	0507SA/PA
	1909 SA/PA	0527SA/PA

Pressure Drop Through Three and Four Circuit YCAV Evaporators

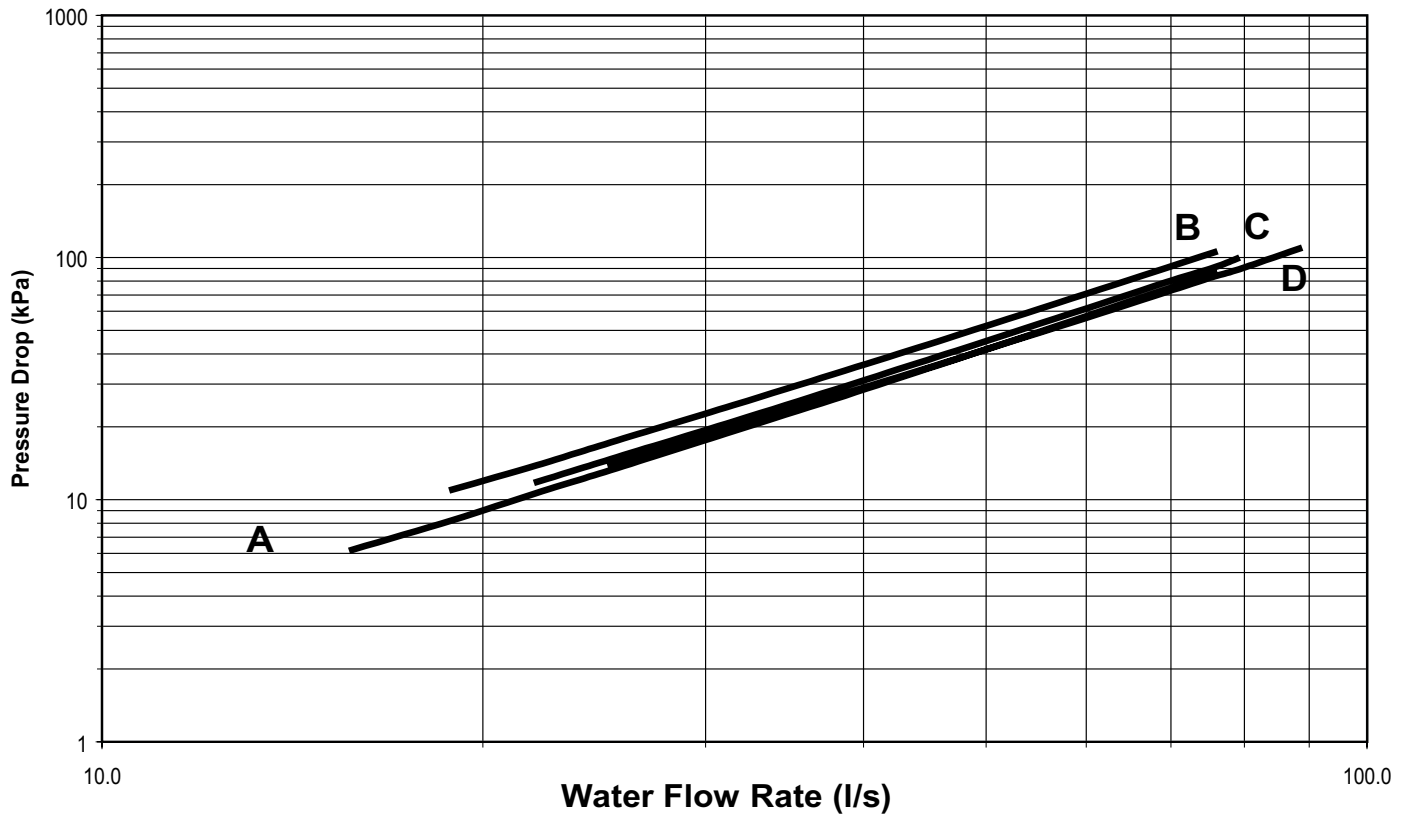

EVAP	YCAV MODELS	
	50Hz	60Hz
A	-	0267EA/VA
	-	0287SA/PA
	-	0287EA/VA
B	-	0307SA/PA
	-	0327EA/VA
	-	0357SA/PA
	-	0357EA/VA
	-	0397SA/PA
C	1429 EA/VA	0397EA/VA
	1549 SA/PA	0417SA/PA
	1649 SA/PA	0457SA/PA
D	1549 EA/VA	0417EA/VA
	1739 SA/PA	0477EA/VA
	1739 EA/VA	0477SA/PA
	1829 SA/PA	0507SA/PA
	1909 SA/PA	0527SA/PA

Efficiency

Standard Full Load Efficiency - 60Hz				
Model Number YCAV	Nominal Capacity	Full Load	Part Load	
		EER	Standard IPLV (S)	Optimized IPLV (P)
0157S/P	152.6	9.6	13.2	14.5
0177S/P	168.4	9.6	13.0	14.8
0187S/P	184.2	9.8	13.1	14.9
0207S/P	197.6	9.6	13.2	14.7
0227S/P	215.3	9.9	13.0	14.7
0247S/P	236.4	9.9	12.7	14.8
0267S/P	257.6	9.9	12.3	14.9
0287S/P	272.7	9.8	13.0	14.7
0307S/P	302.9	9.8	12.6	14.6
0357S/P	342.9	9.9	13.5	15.1
0397S/P	385.3	9.9	13.2	15.2
0417S/P	409.9	9.8	12.5	14.8
0457S/P	439.3	9.8	12.8	14.8
0477S/P	471.0	9.9	12.8	14.7
0507S/P	492.1	9.9	12.5	14.7
0527S/P	513.2	9.9	11.7	14.7

High Full Load Efficiency - 60Hz

Model Number YCAV	Nominal Capacity	Full Load	Part Load	
		EER	Standard IPLV (E)	Optimized IPLV (V)
0157E/V	150.8	10.3	13.5	14.6
0177E/V	161.5	10.4	13.5	14.7
0187E/V	179.4	10.3	13.2	15.1
0197E/V	193.9	10.2	12.9	15.0
0207E/V	206.5	10.4	13.4	15.0
0227E/V	214.9	10.5	13.1	15.0
0247E/V	237.9	10.2	12.8	14.9
0267E/V	269.5	10.4	13.3	14.9
0287E/V	287.1	10.4	12.9	14.8
0327E/V	312.3	10.4	13.8	14.8
0357E/V	353.5	10.4	12.2	15.3
0397E/V	378.2	10.3	12.7	15.0
0417E/V	417.3	10.5	13.3	14.9
0477E/V	458.2	10.5	13.2	14.9

NOTES:

1. Nominal Capacity based on 95°F air on condenser temperature, 44°F Leaving Chilled Water Temperature (LCWT), and 2.4 GPM cooler water per ton.
2. EER = Chiller EER (includes power from compressors, fans, and control panels 0.8 KW)

MODEL: YCAV0157S/P										S IPLV= 13.2			P IPLV= 14.5		
AIR TEMPERATURE ON - CONDENSER (°F)															
LCWT (°F)	105.0			110.0			115.0			120.0			125.0		
	TONS	KW	EER	TONS	KW	EER	TONS	KW	EER	TONS	KW	EER	TONS	KW	EER
40.0	138.9	202.0	7.7	133.5	212.3	7.1	127.9	223.1	6.5	115.1	212.4	6.1	90.1	165.9	6.0
42.0	142.7	202.7	7.9	137.0	213.2	7.3	131.3	223.9	6.6	116.7	208.0	6.3	91.2	162.3	6.2
44.0	146.5	203.4	8.1	140.6	214.0	7.4	134.7	224.7	6.8	118.2	203.3	6.5	92.4	158.7	6.4
45.0	148.4	203.7	8.2	142.5	214.3	7.5	136.5	225.0	6.9	118.9	201.0	6.7	93.0	156.8	6.6
46.0	150.4	204.0	8.3	144.3	214.7	7.6	138.3	225.4	6.9	119.6	198.7	6.8	93.5	155.0	6.7
48.0	154.3	204.7	8.5	148.1	215.4	7.8	141.8	226.3	7.1	121.0	194.2	7.0	94.7	151.4	6.9
50.0	158.2	205.4	8.7	151.9	216.1	7.9	145.5	227.0	7.3	122.4	189.7	7.2	95.8	147.8	7.1
52.0	162.2	206.1	8.9	155.8	216.8	8.1	149.2	227.6	7.4	123.7	185.3	7.5	97.0	144.2	7.4
55.0	168.3	207.2	9.2	161.7	217.8	8.4	151.7	218.9	7.8	125.6	178.7	7.8	98.6	139.0	7.8

MODEL: YCAV0177S/P										S IPLV= 13.0			P IPLV= 14.8		
AIR TEMPERATURE ON - CONDENSER (°F)															
LCWT (°F)	105.0			110.0			115.0			120.0			125.0		
	TONS	KW	EER	TONS	KW	EER	TONS	KW	EER	TONS	KW	EER	TONS	KW	EER
40.0	149.9	214.6	7.9	143.5	222.1	7.3	113.3	172.8	7.3	86.9	131.6	7.2	59.9	90.6	6.9
42.0	154.0	215.3	8.1	146.4	220.0	7.5	114.7	168.8	7.6	88.6	129.9	7.4	61.2	89.5	7.1
44.0	158.3	215.8	8.3	147.9	214.5	7.8	116.0	164.6	7.8	90.4	128.1	7.7	62.5	88.4	7.4
45.0	160.5	216.0	8.4	148.5	211.6	7.9	116.7	162.7	7.9	91.2	127.3	7.8	63.2	87.8	7.5
46.0	162.6	216.2	8.5	149.2	208.6	8.1	117.4	160.9	8.1	92.1	126.4	7.9	63.8	87.3	7.6
48.0	167.0	216.6	8.7	150.7	203.1	8.4	119.0	157.4	8.4	93.7	124.5	8.2	65.2	86.2	7.8
50.0	171.5	217.0	8.9	151.8	197.2	8.6	120.6	154.2	8.6	95.2	122.4	8.4	66.5	85.2	8.1
52.0	176.0	217.4	9.1	153.3	192.3	8.9	122.2	151.0	8.9	96.0	120.4	8.6	67.9	84.2	8.3
55.0	182.9	217.9	9.5	155.0	184.9	9.4	124.4	146.3	9.3	97.3	115.0	9.1	69.7	82.5	8.7

MODEL: YCAV0187S/P										S IPLV= 13.1			P IPLV= 14.9		
AIR TEMPERATURE ON - CONDENSER (°F)															
LCWT (°F)	105.0			110.0			115.0			120.0			125.0		
	TONS	KW	EER	TONS	KW	EER	TONS	KW	EER	TONS	KW	EER	TONS	KW	EER
40.0	166.1	236.3	7.9	159.4	245.3	7.3	152.8	253.9	6.8	133.4	228.4	6.6	105.7	182.8	6.4
42.0	170.5	236.8	8.1	163.7	245.8	7.5	156.9	254.5	7.0	135.1	223.9	6.8	107.1	178.8	6.6
44.0	175.1	237.3	8.3	168.0	246.3	7.7	160.9	255.1	7.1	136.8	219.3	7.0	108.4	174.7	6.9
45.0	177.4	237.5	8.4	170.2	246.5	7.8	163.0	255.4	7.2	137.7	217.0	7.1	109.1	172.6	7.0
46.0	179.7	237.7	8.5	172.5	246.7	7.9	165.1	255.6	7.3	138.6	214.7	7.2	109.7	170.6	7.1
48.0	184.5	238.1	8.7	177.0	247.1	8.1	169.5	256.1	7.5	140.4	210.0	7.5	111.1	166.5	7.3
50.0	189.3	238.4	9.0	181.6	247.5	8.3	171.2	249.6	7.8	142.1	205.2	7.7	112.2	162.1	7.6
52.0	194.1	238.9	9.2	186.3	247.9	8.5	172.9	242.8	8.0	143.5	200.1	8.0	113.3	157.9	7.9
55.0	201.5	239.5	9.5	193.4	248.5	8.8	175.7	233.3	8.5	145.5	192.9	8.4	115.1	152.1	8.3

NOTES:

1. KW = Compressor Input Power
2. EER = Chiller EER (includes power from compressors, fans, and control panels 0.8 KW)
3. LCWT = Leaving Chilled Water Temperature
4. Ratings based on 2.4 GPM cooler water per ton
5. Rated in accordance with ARI Standard 550/590-98
6. Certified in accordance with the ARI Water-Chilling Packages Using the Vapor Compression Cycle Certification Program, which is based on ARI Standard 550/590.

MODEL: YCAV0207S/P										S_IPLV= 13.2			P_IPLV= 14.7		
AIR TEMPERATURE ON - CONDENSER (°F)															
LCWT (°F)	105.0			110.0			115.0			120.0			125.0		
	TONS	KW	EER	TONS	KW	EER	TONS	KW	EER	TONS	KW	EER	TONS	KW	EER
40.0	176.0	254.8	7.8	168.7	261.6	7.3	149.2	238.0	7.1	122.3	197.5	6.9	95.1	154.4	6.7
42.0	180.7	254.7	8.0	173.2	261.8	7.5	151.0	232.8	7.3	123.8	192.9	7.1	96.3	150.9	7.0
44.0	185.4	254.4	8.3	177.7	261.8	7.7	152.8	227.3	7.6	125.3	188.3	7.4	97.5	147.5	7.2
45.0	187.9	254.3	8.4	180.0	261.8	7.8	153.7	224.5	7.7	126.0	186.1	7.5	98.1	145.7	7.3
46.0	190.3	254.1	8.5	182.0	260.9	7.9	154.6	221.8	7.8	126.8	183.8	7.6	98.6	144.0	7.4
48.0	195.3	253.7	8.7	184.0	254.3	8.2	156.2	216.6	8.1	128.2	179.3	7.9	99.7	140.6	7.7
50.0	200.4	253.2	9.0	186.1	247.8	8.5	157.8	211.5	8.4	129.6	174.8	8.2	100.8	137.3	7.9
52.0	205.5	252.8	9.2	188.1	241.3	8.8	159.3	206.5	8.6	130.9	170.4	8.5	101.9	134.0	8.2
55.0	213.4	252.2	9.6	191.0	232.5	9.3	161.6	199.2	9.0	132.8	164.1	8.9	103.4	129.3	8.6

MODEL: YCAV0227S/P										S_IPLV= 12.9			P_IPLV= 14.7		
AIR TEMPERATURE ON - CONDENSER (°F)															
LCWT (°F)	105.0			110.0			115.0			120.0			125.0		
	TONS	KW	EER	TONS	KW	EER	TONS	KW	EER	TONS	KW	EER	TONS	KW	EER
40.0	193.1	269.8	8.1	185.3	277.1	7.6	177.5	283.8	7.1	155.0	255.5	6.8	122.5	203.4	6.7
42.0	198.2	270.0	8.3	190.2	277.4	7.8	182.1	284.2	7.3	156.6	250.0	7.0	124.0	198.7	6.9
44.0	203.5	270.1	8.5	195.2	277.6	8.0	186.9	284.5	7.4	158.4	244.1	7.3	125.5	194.0	7.1
45.0	206.2	270.2	8.6	197.7	277.7	8.1	189.3	284.6	7.5	159.3	241.2	7.4	126.2	191.6	7.3
46.0	208.9	270.2	8.7	200.3	277.7	8.2	191.8	284.7	7.6	160.1	238.2	7.5	126.9	189.2	7.4
48.0	214.4	270.3	9.0	205.6	277.8	8.4	195.2	281.4	7.9	161.9	232.2	7.8	128.0	184.1	7.6
50.0	219.9	270.4	9.2	210.9	277.8	8.6	197.2	274.6	8.1	163.6	226.3	8.1	129.3	179.3	7.9
52.0	225.6	270.4	9.4	216.3	277.8	8.8	199.3	267.5	8.4	165.1	220.6	8.3	130.6	174.7	8.2
55.0	234.3	270.6	9.8	224.6	277.9	9.1	202.2	256.3	8.9	167.4	212.8	8.8	132.7	168.4	8.6

MODEL: YCAV0247S/P										S_IPLV= 12.7			P_IPLV= 14.8		
AIR TEMPERATURE ON - CONDENSER (°F)															
LCWT (°F)	105.0			110.0			115.0			120.0			125.0		
	TONS	KW	EER	TONS	KW	EER	TONS	KW	EER	TONS	KW	EER	TONS	KW	EER
40.0	213.4	297.6	8.1	206.3	308.8	7.6	199.1	319.5	7.1	171.1	280.0	6.9	134.6	221.0	6.7
42.0	219.3	298.4	8.3	211.9	309.5	7.8	204.4	320.4	7.2	172.5	272.6	7.1	136.2	215.8	7.0
44.0	225.3	299.1	8.5	217.6	310.3	7.9	208.9	318.7	7.4	173.9	265.1	7.4	137.7	210.5	7.2
45.0	228.3	299.4	8.6	220.5	310.7	8.0	210.1	315.4	7.6	174.7	261.4	7.5	138.6	208.1	7.3
46.0	231.4	299.7	8.7	223.4	311.1	8.1	211.3	311.8	7.7	175.4	257.8	7.6	139.2	205.4	7.5
48.0	237.6	300.4	8.9	229.4	311.7	8.3	213.6	304.4	7.9	177.0	251.0	7.9	140.8	200.4	7.7
50.0	243.9	301.1	9.2	235.5	312.4	8.5	215.8	296.4	8.2	178.7	244.8	8.1	142.3	195.5	8.0
52.0	250.3	301.8	9.4	241.7	313.0	8.8	217.8	288.1	8.5	180.4	238.8	8.4	143.7	190.7	8.2
55.0	260.2	302.9	9.7	251.2	314.1	9.1	220.5	275.9	9.0	182.8	230.0	8.8	145.8	183.8	8.6

NOTES:

1. kW = Compressor Input Power
2. EER = Chiller EER (includes power from compressors, fans, and control panels 0.8 KW)
3. LCWT = Leaving Chilled Water Temperature
4. Ratings based on 2.4 GPM cooler water per ton
5. Rated in accordance with ARI Standard 550/590-98 and are accordingly certified

MODEL: YCAV0267S/P										S IPLV= 12.3			P IPLV= 14.9		
AIR TEMPERATURE ON - CONDENSER (°F)															
LCWT (°F)	105.0			110.0			115.0			120.0			125.0		
	TONS	KW	EER	TONS	KW	EER	TONS	KW	EER	TONS	KW	EER	TONS	KW	EER
40.0	233.9	325.1	8.1	227.3	340.0	7.6	220.8	354.7	7.1	189.2	308.2	6.9	150.5	246.4	6.8
42.0	240.4	326.4	8.3	233.6	341.3	7.8	226.8	356.2	7.2	191.2	301.0	7.1	152.2	240.6	7.0
44.0	247.1	327.6	8.5	240.1	342.6	7.9	231.8	354.5	7.4	193.2	293.9	7.4	153.7	234.6	7.2
45.0	250.5	328.3	8.6	243.4	343.2	8.0	233.0	350.2	7.5	194.2	290.4	7.5	154.7	231.9	7.4
46.0	253.9	328.9	8.7	246.7	344.0	8.1	234.2	345.7	7.7	195.2	286.8	7.6	155.4	228.9	7.5
48.0	260.9	330.1	8.9	253.4	345.2	8.3	236.7	336.8	8.0	197.2	279.9	7.9	157.0	223.3	7.7
50.0	267.9	331.5	9.1	260.2	346.5	8.5	239.1	327.9	8.2	199.1	273.0	8.2	158.6	217.8	8.0
52.0	275.1	332.8	9.4	267.2	347.8	8.7	241.5	319.2	8.5	201.0	266.3	8.4	160.1	212.5	8.3
55.0	286.1	334.8	9.7	277.9	349.8	9.0	244.8	307.1	9.0	203.8	256.4	8.8	162.4	204.7	8.7

MODEL: YCAV0287S/P										S IPLV= 13.0			P IPLV= 14.7		
AIR TEMPERATURE ON - CONDENSER (°F)															
LCWT (°F)	105.0			110.0			115.0			120.0			125.0		
	TONS	KW	EER	TONS	KW	EER	TONS	KW	EER	TONS	KW	EER	TONS	KW	EER
40.0	244.3	345.3	8.0	234.1	356.5	7.4	209.5	332.8	7.1	171.7	277.6	6.9	133.4	217.0	6.7
42.0	250.9	345.8	8.2	240.4	357.3	7.6	211.9	325.4	7.3	173.8	271.4	7.1	135.1	212.1	6.9
44.0	257.7	346.2	8.4	246.8	357.8	7.8	214.8	318.9	7.6	175.9	265.2	7.4	136.8	207.3	7.2
45.0	261.2	346.3	8.5	250.0	358.2	7.9	216.1	315.4	7.7	177.0	262.0	7.5	137.6	204.9	7.3
46.0	264.7	346.4	8.6	253.4	358.4	8.0	217.5	311.9	7.8	178.0	258.9	7.6	138.4	202.5	7.4
48.0	271.7	346.6	8.9	258.9	355.8	8.2	220.1	304.8	8.1	180.1	252.6	7.9	140.0	197.8	7.7
50.0	278.9	346.7	9.1	261.9	347.2	8.5	222.4	297.7	8.4	182.1	246.4	8.1	141.6	193.1	7.9
52.0	286.2	346.8	9.3	264.9	338.8	8.8	224.6	290.7	8.6	184.1	240.4	8.4	143.1	188.5	8.2
55.0	297.4	346.9	9.7	269.4	327.1	9.3	227.7	280.5	9.0	186.7	231.4	8.8	145.3	181.9	8.6

MODEL: YCAV0307S/P										S IPLV= 12.6			P IPLV= 14.6		
AIR TEMPERATURE ON - CONDENSER (°F)															
LCWT (°F)	105.0			110.0			115.0			120.0			125.0		
	TONS	KW	EER	TONS	KW	EER	TONS	KW	EER	TONS	KW	EER	TONS	KW	EER
40.0	271.4	384.3	8.0	260.3	394.8	7.5	229.5	358.3	7.2	188.0	297.1	7.0	146.1	232.3	6.9
42.0	278.6	384.1	8.2	267.2	395.1	7.7	232.1	349.9	7.5	190.2	290.4	7.3	147.9	227.0	7.1
44.0	286.0	383.8	8.4	274.2	395.1	7.9	235.1	342.1	7.7	192.5	283.6	7.5	149.7	221.9	7.3
45.0	289.7	383.6	8.5	277.7	395.0	8.0	236.5	338.1	7.8	193.7	280.2	7.7	150.6	219.3	7.4
46.0	293.5	383.3	8.7	280.1	392.1	8.1	237.9	334.0	8.0	194.8	276.8	7.8	151.5	216.7	7.6
48.0	301.2	382.7	8.9	283.2	382.4	8.4	240.7	326.4	8.3	197.1	270.0	8.1	153.2	211.7	7.8
50.0	309.0	382.1	9.1	286.4	372.5	8.7	243.0	318.5	8.5	199.2	263.4	8.3	154.9	206.7	8.1
52.0	317.0	381.4	9.4	289.6	362.8	9.0	245.3	311.0	8.8	201.3	256.9	8.6	156.5	201.8	8.3
55.0	329.2	380.5	9.8	294.2	349.6	9.5	248.8	300.0	9.2	204.2	247.3	9.0	158.8	194.6	8.7

NOTES:

1. kW = Compressor Input Power
2. EER = Chiller EER (includes power from compressors, fans, and control panels 0.8 KW)
3. LCWT = Leaving Chilled Water Temperature
4. Ratings based on 2.4 GPM cooler water per ton
5. Rated in accordance with ARI Standard 550/590-98 and are accordingly certified

MODEL: YCAV0357S/P										S IPLV= 13.5			P IPLV= 15.1		
AIR TEMPERATURE ON - CONDENSER (°F)															
LCWT (°F)	105.0			110.0			115.0			120.0			125.0		
	TONS	KW	EER	TONS	KW	EER	TONS	KW	EER	TONS	KW	EER	TONS	KW	EER
40.0	309.3	432.1	8.1	298.3	446.9	7.6	287.4	460.8	7.1	249.1	409.5	6.8	194.9	321.5	6.7
42.0	317.7	433.0	8.3	306.3	447.8	7.7	295.0	462.0	7.2	250.9	398.8	7.1	197.2	314.0	6.9
44.0	326.3	433.8	8.5	314.6	448.7	7.9	302.8	463.1	7.4	252.7	387.4	7.3	199.6	306.5	7.2
45.0	330.7	434.1	8.6	318.7	449.1	8.0	304.8	459.0	7.5	253.6	381.7	7.4	200.6	302.5	7.3
46.0	335.1	434.5	8.7	322.9	449.5	8.1	306.7	454.4	7.6	254.6	376.1	7.6	201.9	299.1	7.4
48.0	344.0	435.2	8.9	331.5	450.3	8.3	310.2	444.4	7.9	256.8	365.7	7.8	204.0	291.6	7.7
50.0	353.1	435.9	9.2	340.2	450.9	8.5	313.5	433.3	8.2	259.2	356.4	8.1	206.3	284.5	7.9
52.0	362.4	436.7	9.4	349.2	451.6	8.8	316.5	421.3	8.5	261.6	347.7	8.4	208.4	277.6	8.2
55.0	376.6	437.8	9.7	362.8	452.6	9.1	320.4	402.9	8.9	265.1	334.9	8.8	211.5	267.5	8.6

MODEL: YCAV0397S/P										S IPLV= 13.2			P IPLV= 15.2		
AIR TEMPERATURE ON - CONDENSER (°F)															
LCWT (°F)	105.0			110.0			115.0			120.0			125.0		
	TONS	KW	EER	TONS	KW	EER	TONS	KW	EER	TONS	KW	EER	TONS	KW	EER
40.0	350.0	486.9	8.1	340.3	509.2	7.6	330.6	531.2	7.1	284.8	466.2	6.9	226.6	372.6	6.7
42.0	359.8	488.8	8.3	349.7	511.2	7.8	339.5	533.5	7.2	287.9	455.5	7.1	229.2	363.9	7.0
44.0	369.8	490.8	8.5	359.3	513.2	7.9	348.7	535.6	7.4	290.9	444.8	7.3	231.7	355.3	7.2
45.0	374.9	491.7	8.6	364.2	514.2	8.0	350.8	530.1	7.5	292.5	439.5	7.5	232.8	350.6	7.3
46.0	380.0	492.6	8.7	369.2	515.1	8.1	352.7	523.5	7.6	294.0	434.2	7.6	234.2	346.7	7.5
48.0	390.5	494.5	8.9	379.2	517.2	8.3	356.3	510.3	7.9	296.9	423.7	7.9	236.5	337.9	7.7
50.0	401.1	496.5	9.1	389.5	519.0	8.5	360.0	496.9	8.2	299.9	413.4	8.1	238.9	329.7	8.0
52.0	411.9	498.5	9.3	400.0	521.0	8.7	363.7	483.8	8.5	302.8	403.2	8.4	241.2	321.6	8.2
55.0	428.7	501.5	9.7	416.1	524.0	9.0	368.8	465.1	8.9	306.9	388.3	8.8	244.7	309.9	8.6

MODEL: YCAV0417S/P										S IPLV= 12.5			P IPLV= 14.8		
AIR TEMPERATURE ON - CONDENSER (°F)															
LCWT (°F)	105.0			110.0			115.0			120.0			125.0		
	TONS	KW	EER	TONS	KW	EER	TONS	KW	EER	TONS	KW	EER	TONS	KW	EER
40.0	371.6	528.5	7.9	357.2	542.9	7.4	342.8	555.7	7.0	309.4	521.0	6.7	245.0	414.4	6.6
42.0	381.6	528.7	8.1	366.6	543.6	7.6	351.8	556.8	7.1	312.5	510.9	6.9	247.7	404.5	6.8
44.0	391.7	528.8	8.4	376.3	543.9	7.8	361.0	557.6	7.3	315.8	499.8	7.1	250.6	395.1	7.0
45.0	396.9	528.8	8.5	381.3	544.0	7.9	365.7	557.8	7.4	317.5	494.0	7.2	252.1	390.4	7.1
46.0	402.0	528.7	8.6	386.3	544.0	8.0	370.4	558.1	7.5	319.3	488.0	7.3	253.6	385.7	7.3
48.0	412.3	528.4	8.8	396.4	544.0	8.2	380.0	558.2	7.7	322.9	476.0	7.6	256.5	376.2	7.5
50.0	422.8	528.1	9.0	406.5	543.7	8.4	389.9	558.2	7.9	326.5	463.8	7.9	258.8	365.9	7.8
52.0	433.5	527.7	9.3	416.8	543.4	8.7	396.9	551.1	8.1	330.0	452.0	8.2	261.4	356.4	8.0
55.0	449.7	527.2	9.6	432.5	542.7	9.0	403.2	529.5	8.6	334.5	435.2	8.6	265.2	342.9	8.5

NOTES:

1. kW = Compressor Input Power
2. EER = Chiller EER (includes power from compressors, fans, and control panels 0.8 kW)
3. LCWT = Leaving Chilled Water Temperature
4. Ratings based on 2.4 GPM cooler water per ton
5. Rated in accordance with ARI Standard 550/590-98 and are accordingly certified

Standard Efficiency Ratings – English - 60Hz

MODEL: YCAV0457S/P

S IPLV= 12.6

P IPLV= 14.7

AIR TEMPERATURE ON - CONDENSER (°F)

LCWT (°F)	75.0			80.0			85.0			90.0			95.0			100.0		
	TONS	KW	EER	TONS	KW	EER	TONS	KW	EER	TONS	KW	EER	TONS	KW	EER	TONS	KW	EER
40.0	429.2	377.0	12.5	425.5	406.0	11.6	421.4	436.7	10.7	416.9	469.3	9.9	412.1	503.3	9.2	406.2	539.9	8.5
42.0	442.4	380.2	12.8	438.5	408.9	11.8	434.3	439.6	11.0	429.7	472.2	10.2	424.7	506.3	9.4	418.3	542.8	8.7
44.0	455.8	383.7	13.1	451.8	412.2	12.1	447.4	442.7	11.2	442.6	475.2	10.4	437.4	509.4	9.6	430.6	545.6	8.9
45.0	462.5	385.5	13.2	458.5	413.9	12.2	454.0	444.3	11.4	449.1	476.8	10.5	443.9	510.9	9.8	436.7	547.0	9.0
46.0	469.4	387.3	13.3	465.3	415.6	12.4	460.7	446.1	11.5	455.7	478.5	10.6	450.4	512.6	9.9	443.0	548.4	9.1
48.0	483.2	391.4	13.6	479.0	419.4	12.6	474.3	449.6	11.7	469.1	481.9	10.9	463.5	516.1	10.1	455.6	551.3	9.3
50.0	497.2	395.7	13.8	492.9	423.4	12.9	488.1	453.4	12.0	482.7	485.6	11.1	476.7	519.1	10.3	468.2	553.9	9.5
52.0	511.5	400.3	14.1	507.1	427.7	13.1	502.1	457.5	12.2	496.6	489.4	11.4	490.1	522.3	10.5	480.5	555.4	9.8
55.0	533.4	407.8	14.4	528.8	434.7	13.5	523.6	464.1	12.6	517.8	495.8	11.7	510.6	527.5	10.9	499.2	557.5	10.1

MODEL: YCAV0477S/P

S IPLV= 12.8

P IPLV= 14.7

AIR TEMPERATURE ON - CONDENSER (°F)

LCWT (°F)	75.0			80.0			85.0			90.0			95.0			100.0		
	TONS	KW	EER	TONS	KW	EER	TONS	KW	EER	TONS	KW	EER	TONS	KW	EER	TONS	KW	EER
40.0	461.7	396.3	12.8	457.7	426.2	11.9	453.3	458.5	11.0	448.6	492.1	10.2	443.5	527.5	9.4	437.7	567.3	8.7
42.0	476.2	399.8	13.1	472.0	429.7	12.1	467.4	461.7	11.2	462.5	495.5	10.4	457.1	530.9	9.7	451.0	570.9	8.9
44.0	491.0	403.6	13.4	486.7	433.4	12.4	481.9	465.2	11.5	476.6	499.1	10.7	471.0	534.5	9.9	464.5	574.4	9.1
45.0	498.6	405.7	13.5	494.1	435.3	12.6	489.2	467.0	11.6	483.9	500.8	10.8	478.1	536.4	10.0	470.8	575.1	9.2
46.0	506.2	408.0	13.7	501.7	437.3	12.7	496.6	469.0	11.8	491.1	502.8	10.9	485.3	538.3	10.1	477.2	575.8	9.3
48.0	521.7	412.4	13.9	517.0	441.5	13.0	511.7	473.0	12.0	506.0	506.7	11.2	499.8	542.3	10.4	490.1	577.3	9.6
50.0	537.3	417.1	14.2	532.4	446.1	13.2	527.1	477.3	12.3	521.2	510.8	11.4	514.7	546.3	10.6	503.3	578.7	9.8
52.0	553.0	422.3	14.5	548.1	450.8	13.5	542.5	481.9	12.5	536.5	515.1	11.7	530.0	550.6	10.8	516.7	580.2	10.0
55.0	577.7	429.6	14.9	572.0	458.6	13.9	566.2	489.1	12.9	559.8	522.2	12.0	552.9	557.5	11.2	537.0	582.7	10.4

MODEL: YCAV0507S/P

S IPLV= 12.5

P IPLV= 14.7

AIR TEMPERATURE ON - CONDENSER (°F)

LCWT (°F)	75.0			80.0			85.0			90.0			95.0			100.0		
	TONS	KW	EER	TONS	KW	EER	TONS	KW	EER	TONS	KW	EER	TONS	KW	EER	TONS	KW	EER
40.0	482.0	414.4	12.8	478.0	445.5	11.8	473.5	478.8	11.0	468.6	513.7	10.2	463.4	550.3	9.4	457.4	591.4	8.7
42.0	497.2	418.2	13.1	492.9	449.2	12.1	488.2	482.4	11.2	483.1	517.4	10.4	477.6	553.9	9.7	471.3	595.3	8.9
44.0	512.7	422.2	13.3	508.2	453.2	12.4	503.3	486.1	11.5	497.9	521.1	10.7	492.1	558.0	9.9	485.4	599.2	9.1
45.0	520.5	424.4	13.5	516.0	455.2	12.5	510.9	488.1	11.6	505.4	523.1	10.8	499.5	560.0	10.0	492.2	600.3	9.2
46.0	528.5	426.8	13.6	523.8	457.3	12.7	518.6	490.3	11.8	513.0	525.3	10.9	507.0	562.0	10.1	498.9	601.3	9.4
48.0	544.6	431.5	13.9	539.8	461.8	12.9	534.4	494.5	12.0	528.5	529.5	11.2	522.1	566.4	10.4	512.5	603.4	9.6
50.0	560.7	436.3	14.2	555.8	466.6	13.2	550.4	499.1	12.3	544.3	533.9	11.4	537.7	570.8	10.6	526.5	605.4	9.8
52.0	577.0	441.6	14.4	572.0	471.5	13.5	566.3	504.0	12.5	560.2	538.5	11.6	553.5	575.3	10.8	540.7	607.5	10.0
55.0	602.4	448.6	14.8	596.7	479.6	13.8	590.8	511.5	12.9	584.3	545.9	12.0	577.2	582.5	11.2	562.1	611.0	10.4

NOTES:

1. kW = Compressor Input Power
2. EER = Chiller EER (includes power from compressors, fans, and control panels 0.8 kW)
3. LCWT = Leaving Chilled Water Temperature
4. Ratings based on 2.4 GPM cooler water per ton
5. Rated in accordance with ARI Standard 550/590-98 and are accordingly certified

MODEL: YCAV0457S/P										S IPLV= 12.6			P IPLV= 14.7		
AIR TEMPERATURE ON - CONDENSER (°F)															
LCWT (°F)	105.0			110.0			115.0			120.0			125.0		
	TONS	KW	EER	TONS	KW	EER	TONS	KW	EER	TONS	KW	EER	TONS	KW	EER
40.0	396.8	569.8	7.9	383.8	591.2	7.4	350.0	560.6	7.0	285.4	457.8	6.9	225.7	363.7	6.8
42.0	407.8	571.2	8.1	394.3	592.9	7.5	353.4	546.9	7.3	289.0	447.4	7.2	228.4	355.1	7.0
44.0	418.9	572.6	8.3	404.9	594.4	7.7	356.7	532.2	7.5	292.4	437.0	7.4	231.1	346.8	7.3
45.0	424.6	573.2	8.4	410.3	595.1	7.8	358.3	524.8	7.7	294.1	431.8	7.6	232.5	342.8	7.4
46.0	430.3	573.9	8.5	415.8	595.8	7.9	360.0	517.6	7.8	295.8	426.6	7.7	233.8	338.7	7.5
48.0	441.8	575.1	8.7	427.0	597.0	8.1	363.3	503.7	8.1	299.2	416.4	7.9	236.5	330.7	7.8
50.0	453.4	576.2	8.9	432.0	582.3	8.4	366.8	490.8	8.4	302.5	406.3	8.2	238.5	321.9	8.0
52.0	465.3	577.4	9.1	436.5	566.8	8.7	370.4	478.7	8.6	305.7	396.5	8.5	240.8	313.8	8.3
55.0	483.3	579.5	9.4	442.7	543.4	9.2	375.5	461.2	9.1	310.1	381.7	8.9	244.2	302.2	8.7

MODEL: YCAV0477S/P										S IPLV= 12.8			P IPLV= 14.7		
AIR TEMPERATURE ON - CONDENSER (°F)															
LCWT (°F)	105.0			110.0			115.0			120.0			125.0		
	TONS	KW	EER	TONS	KW	EER	TONS	KW	EER	TONS	KW	EER	TONS	KW	EER
40.0	425.7	594.6	8.1	411.5	616.8	7.6	397.4	638.2	7.1	343.9	565.1	6.9	270.4	445.7	6.7
42.0	437.4	596.1	8.3	422.7	618.5	7.7	408.0	640.1	7.2	346.8	550.8	7.1	273.6	435.3	7.0
44.0	449.3	597.6	8.5	434.1	620.0	7.9	418.9	641.9	7.4	349.6	535.8	7.3	276.8	424.9	7.2
45.0	455.4	598.3	8.6	440.0	620.7	8.0	421.7	636.1	7.5	351.1	528.3	7.5	278.1	419.3	7.3
46.0	461.5	598.9	8.7	445.8	621.5	8.1	424.1	629.3	7.6	352.6	521.0	7.6	279.9	414.6	7.4
48.0	474.0	600.2	8.9	457.7	622.9	8.3	428.9	614.8	7.9	355.7	507.0	7.8	282.8	404.2	7.7
50.0	486.6	601.7	9.1	469.9	624.2	8.5	433.5	599.2	8.2	359.1	494.3	8.1	285.9	394.4	8.0
52.0	499.5	603.1	9.4	482.3	625.5	8.7	437.7	582.8	8.5	362.5	482.2	8.4	288.8	384.7	8.2
55.0	519.3	605.2	9.7	501.4	627.6	9.1	443.3	558.1	8.9	367.4	464.4	8.8	293.0	370.8	8.6

MODEL: YCAV0507S/P										S IPLV= 12.5			P IPLV= 14.7		
AIR TEMPERATURE ON - CONDENSER (°F)															
LCWT (°F)	105.0			110.0			115.0			120.0			125.0		
	TONS	KW	EER	TONS	KW	EER	TONS	KW	EER	TONS	KW	EER	TONS	KW	EER
40.0	446.0	621.9	8.1	432.4	648.0	7.6	418.9	673.3	7.1	361.8	593.5	6.9	286.2	471.2	6.7
42.0	458.3	623.9	8.3	444.3	650.1	7.7	430.2	675.8	7.2	365.3	579.1	7.1	289.5	460.2	7.0
44.0	470.9	626.0	8.5	456.4	652.2	7.9	441.8	678.1	7.4	368.7	564.5	7.3	292.9	449.3	7.2
45.0	477.4	627.0	8.6	462.6	653.2	8.0	444.6	671.6	7.5	370.5	557.2	7.5	294.2	443.4	7.3
46.0	483.9	627.9	8.7	468.8	654.2	8.1	447.1	663.9	7.6	372.2	550.0	7.6	296.1	438.4	7.4
48.0	497.1	629.8	8.9	481.5	656.3	8.3	452.0	647.7	7.9	375.8	536.0	7.8	299.1	427.4	7.7
50.0	510.5	631.9	9.1	494.4	658.2	8.5	456.7	631.0	8.2	379.5	522.8	8.1	302.2	416.9	8.0
52.0	524.2	633.9	9.4	507.7	660.1	8.7	461.2	614.0	8.5	383.1	509.9	8.4	305.2	406.7	8.2
55.0	545.2	637.0	9.7	527.9	663.2	9.0	467.5	589.2	8.9	388.3	491.1	8.8	309.6	391.9	8.6

NOTES:

1. kW = Compressor Input Power
2. EER = Chiller EER (includes power from compressors, fans, and control panels 0.8 kW)
3. LCWT = Leaving Chilled Water Temperature
4. Ratings based on 2.4 GPM cooler water per ton
5. Rated in accordance with ARI Standard 550/590-98 and are accordingly certified

Standard Efficiency Ratings – English - 60Hz

MODEL: YCAV0527S/P

S_IPLV= 11.7

P_IPLV= 14.7

AIR TEMPERATURE ON - CONDENSER (°F)

LCWT (°F)	75.0			80.0			85.0			90.0			95.0			100.0		
	TONS	KW	EER	TONS	KW	EER	TONS	KW	EER	TONS	KW	EER	TONS	KW	EER	TONS	KW	EER
40.0	502.5	432.5	12.8	498.3	464.7	11.8	493.7	499.1	11.0	488.7	535.1	10.2	483.3	572.9	9.5	477.1	615.4	8.7
42.0	518.2	436.5	13.0	513.9	468.6	12.1	509.0	502.9	11.2	503.7	539.2	10.4	498.1	576.9	9.7	491.6	619.6	8.9
44.0	534.3	440.8	13.3	529.8	472.9	12.4	524.7	507.0	11.5	519.2	543.2	10.7	513.2	581.3	9.9	506.4	624.0	9.1
45.0	542.5	443.0	13.5	537.8	475.1	12.5	532.7	509.1	11.6	527.0	545.3	10.8	520.9	583.4	10.0	513.5	625.4	9.3
46.0	550.8	445.5	13.6	546.0	477.3	12.7	540.7	511.5	11.8	534.9	547.7	10.9	528.7	585.6	10.1	520.6	626.6	9.4
48.0	567.6	450.4	13.9	562.6	482.0	12.9	557.1	516.0	12.0	551.0	552.2	11.2	544.5	590.3	10.4	535.0	629.3	9.6
50.0	584.2	455.4	14.1	579.2	487.0	13.2	573.8	520.8	12.3	567.5	556.9	11.4	560.7	595.0	10.6	549.7	631.9	9.8
52.0	601.0	460.9	14.4	595.9	492.1	13.4	590.2	525.9	12.5	583.9	561.7	11.6	577.1	599.9	10.8	564.7	634.6	10.0
55.0	627.1	467.5	14.8	621.4	500.4	13.8	615.4	533.7	12.9	608.8	569.4	12.0	601.6	607.5	11.1	587.3	639.1	10.4

NOTES:

1. kW = Compressor Input Power
2. EER = Chiller EER (includes power from compressors, fans, and control panels 0.8 KW)
3. LCWT = Leaving Chilled Water Temperature
4. Ratings based on 2.4 GPM cooler water per ton
5. Rated in accordance with ARI Standard 550/590-98 and are accordingly certified

MODEL: YCAV0527S/P									S_IPLV= 11.7			P_IPLV= 14.7			
AIR TEMPERATURE ON - CONDENSER (°F)															
LCWT (°F)	105.0			110.0			115.0			120.0			125.0		
	TONS	KW	EER	TONS	KW	EER	TONS	KW	EER	TONS	KW	EER	TONS	KW	EER
40.0	466.3	649.1	8.1	453.4	678.9	7.6	440.5	708.2	7.1	379.7	621.6	6.9	302.1	496.7	6.8
42.0	479.3	651.6	8.3	465.9	681.6	7.7	452.5	711.3	7.2	383.8	607.3	7.1	305.6	485.1	7.0
44.0	492.6	654.3	8.5	478.8	684.2	7.9	464.8	714.1	7.4	387.9	593.0	7.4	309.0	473.5	7.2
45.0	499.4	655.5	8.6	485.3	685.5	8.0	467.7	707.0	7.5	390.0	585.9	7.5	310.4	467.3	7.3
46.0	506.3	656.8	8.7	492.0	686.8	8.1	470.1	698.3	7.6	392.0	578.9	7.6	312.4	462.1	7.5
48.0	520.3	659.3	8.9	505.3	689.5	8.3	475.1	680.6	7.9	395.9	564.9	7.9	315.3	450.4	7.7
50.0	534.4	662.0	9.1	519.1	692.0	8.5	480.0	662.7	8.2	399.9	551.1	8.1	318.6	439.4	8.0
52.0	548.9	664.6	9.3	533.1	694.6	8.7	484.9	645.1	8.5	403.8	537.5	8.4	321.7	428.6	8.2
55.0	571.2	668.6	9.7	554.5	698.7	9.0	491.8	620.2	8.9	409.3	517.7	8.8	326.3	413.0	8.6

NOTES:

1. kW = Compressor Input Power
2. EER = Chiller EER (includes power from compressors, fans, and control panels 0.8 KW)
3. LCWT = Leaving Chilled Water Temperature
4. Ratings based on 2.4 GPM cooler water per ton
5. Rated in accordance with ARI Standard 550/590-98 and are accordingly certified

High Efficiency Ratings – English - 60Hz

MODEL: YCAV0157E/V													E_IPLV= 13.5			V_IPLV= 14.6		
AIR TEMPERATURE ON - CONDENSER (°F)																		
LCWT (°F)	75.0			80.0			85.0			90.0			95.0			100.0		
	TONS	KW	EER	TONS	KW	EER	TONS	KW	EER	TONS	KW	EER	TONS	KW	EER	TONS	KW	EER
40.0	148.1	121.7	13.1	146.8	130.5	12.2	145.2	139.6	11.4	143.4	149.1	10.6	141.4	158.9	9.8	139.1	170.1	9.1
42.0	152.7	122.8	13.4	151.5	131.6	12.5	149.9	140.8	11.7	148.1	150.3	10.9	146.1	160.2	10.1	143.7	171.4	9.3
44.0	157.4	123.9	13.8	156.2	132.8	12.8	154.7	142.0	11.9	152.8	151.6	11.1	150.8	161.6	10.3	148.3	172.8	9.6
45.0	159.8	124.4	13.9	158.6	133.4	13.0	157.1	142.6	12.1	155.2	152.2	11.2	153.2	162.2	10.5	150.7	173.5	9.7
46.0	162.2	125.1	14.1	161.0	134.0	13.1	159.5	143.2	12.2	157.7	152.9	11.4	155.6	162.9	10.6	153.0	174.2	9.8
48.0	167.0	126.2	14.4	165.9	135.2	13.4	164.4	144.6	12.5	162.6	154.2	11.6	160.4	164.3	10.8	157.9	175.6	10.0
50.0	171.9	127.3	14.7	170.8	136.4	13.7	169.3	145.9	12.8	167.5	155.7	11.9	165.4	165.8	11.1	162.7	177.2	10.2
52.0	176.8	128.5	15.0	175.8	137.7	14.0	174.4	147.2	13.0	172.6	157.1	12.1	170.4	167.2	11.3	167.7	178.7	10.5
55.0	184.4	130.2	15.4	183.5	139.6	14.4	182.1	149.2	13.4	180.3	159.2	12.5	178.1	169.5	11.7	174.8	180.6	10.8

MODEL: YCAV0177E/V													E_IPLV= 13.5			V_IPLV= 14.7		
AIR TEMPERATURE ON - CONDENSER (°F)																		
LCWT (°F)	75.0			80.0			85.0			90.0			95.0			100.0		
	TONS	KW	EER	TONS	KW	EER	TONS	KW	EER	TONS	KW	EER	TONS	KW	EER	TONS	KW	EER
40.0	157.5	127.7	13.2	156.3	137.3	12.3	155.0	147.6	11.4	153.5	158.6	10.6	151.9	170.1	9.8	150.0	183.2	9.1
42.0	162.5	128.7	13.6	161.3	138.3	12.6	159.9	148.5	11.7	158.3	159.4	10.9	156.6	171.0	10.1	154.7	184.1	9.3
44.0	167.6	129.9	13.9	166.3	139.3	12.9	164.8	149.5	12.0	163.2	160.4	11.2	161.5	171.9	10.4	159.4	185.0	9.6
45.0	170.2	130.5	14.0	168.9	139.9	13.1	167.4	150.1	12.2	165.7	160.9	11.3	163.9	172.4	10.5	161.8	185.5	9.7
46.0	172.8	131.2	14.2	171.4	140.5	13.2	169.9	150.6	12.3	168.2	161.4	11.4	166.4	172.9	10.6	164.3	186.0	9.8
48.0	178.0	132.6	14.5	176.7	141.8	13.5	175.1	151.8	12.6	173.4	162.5	11.7	171.5	174.0	10.9	169.1	186.9	10.0
50.0	183.4	134.1	14.8	182.0	143.1	13.8	180.4	153.0	12.9	178.6	163.7	12.0	176.6	175.1	11.1	173.9	187.8	10.3
52.0	188.9	135.7	15.0	187.5	144.6	14.1	185.8	154.4	13.2	183.9	165.0	12.3	181.9	176.3	11.4	178.7	188.7	10.5
55.0	197.4	138.4	15.4	195.8	147.0	14.5	194.1	156.6	13.6	192.2	167.0	12.7	190.0	178.3	11.8	186.2	190.2	10.9

MODEL: YCAV0187E/V													E_IPLV= 13.2			V_IPLV= 15.1		
AIR TEMPERATURE ON - CONDENSER (°F)																		
LCWT (°F)	75.0			80.0			85.0			90.0			95.0			100.0		
	TONS	KW	EER	TONS	KW	EER	TONS	KW	EER	TONS	KW	EER	TONS	KW	EER	TONS	KW	EER
40.0	175.0	141.6	13.3	173.7	152.7	12.3	172.2	164.6	11.4	170.5	177.2	10.5	168.7	190.5	9.8	166.5	205.3	9.0
42.0	180.5	142.7	13.6	179.2	153.6	12.6	177.7	165.4	11.7	175.9	178.0	10.8	174.0	191.3	10.0	171.7	206.3	9.2
44.0	186.1	143.9	13.9	184.8	154.7	12.9	183.2	166.4	12.0	181.4	178.9	11.1	179.4	192.1	10.3	177.0	207.2	9.5
45.0	189.0	144.5	14.1	187.6	155.3	13.1	186.0	166.9	12.2	184.2	179.4	11.3	182.1	192.6	10.4	179.7	207.7	9.6
46.0	191.8	145.2	14.2	190.4	155.8	13.2	188.8	167.4	12.3	187.0	179.9	11.4	184.9	193.1	10.6	182.5	208.1	9.7
48.0	197.5	146.7	14.5	196.2	157.1	13.5	194.5	168.6	12.6	192.6	180.9	11.7	190.5	194.1	10.8	188.0	209.1	10.0
50.0	203.4	148.3	14.8	202.0	158.6	13.8	200.3	169.8	12.9	198.4	182.1	12.0	196.2	195.2	11.1	193.3	209.5	10.2
52.0	209.3	150.0	15.1	207.9	160.1	14.1	206.2	171.3	13.2	204.2	183.4	12.2	202.0	196.4	11.4	198.6	210.0	10.5
55.0	218.4	153.0	15.4	217.0	162.7	14.5	215.3	173.6	13.6	213.2	185.5	12.6	210.9	198.4	11.8	206.8	210.7	10.9

NOTES:

1. kW = Compressor Input Power
2. EER = Chiller EER (includes power from compressors, fans, and control panel's 0.8 KW)
3. LCWT = Leaving Chilled Water Temperature
4. Ratings based on 2.4 GPM cooler water per ton
5. Rated in accordance with ARI Standard 550/590.

MODEL: YCAV0157E/V**E IPLV= 13.5****V IPLV= 14.6****AIR TEMPERATURE ON - CONDENSER (°F)**

LCWT (°F)	105.0			110.0			115.0			120.0			125.0		
	TONS	KW	EER	TONS	KW	EER	TONS	KW	EER	TONS	KW	EER	TONS	KW	EER
40.0	136.1	181.5	8.4	130.1	190.6	7.7	116.7	182.0	7.2	89.1	139.2	7.0	67.7	107.7	6.7
42.0	140.1	182.5	8.6	133.9	191.5	7.8	118.4	178.7	7.4	90.7	137.1	7.2	68.9	106.0	6.9
44.0	144.2	183.5	8.8	137.7	192.5	8.0	120.1	175.4	7.6	92.3	134.9	7.5	69.9	103.9	7.2
45.0	146.3	184.0	8.9	139.7	193.0	8.1	121.0	173.7	7.8	93.1	133.7	7.6	70.5	102.9	7.3
46.0	148.3	184.5	9.0	141.7	193.5	8.2	121.8	172.0	7.9	93.7	132.4	7.7	71.0	101.9	7.4
48.0	152.5	185.5	9.2	145.7	194.5	8.4	123.1	168.1	8.1	95.1	129.9	8.0	72.0	100.0	7.6
50.0	156.7	186.5	9.4	149.8	195.5	8.6	124.2	164.0	8.4	96.3	127.0	8.2	73.1	98.2	7.9
52.0	161.0	187.6	9.6	152.5	193.3	8.9	125.4	160.0	8.7	97.3	124.1	8.5	74.1	96.4	8.1
55.0	167.5	189.3	9.9	155.3	187.4	9.3	127.0	154.3	9.1	99.2	120.5	8.9	75.7	93.7	8.5

MODEL: YCAV0177E/V**E IPLV= 13.5****V IPLV= 14.7****AIR TEMPERATURE ON - CONDENSER (°F)**

LCWT (°F)	105.0			110.0			115.0			120.0			125.0		
	TONS	KW	EER	TONS	KW	EER	TONS	KW	EER	TONS	KW	EER	TONS	KW	EER
40.0	147.0	195.7	8.4	142.2	207.3	7.7	136.2	217.9	7.0	120.2	201.8	6.7	93.3	159.4	6.4
42.0	151.2	196.5	8.6	146.1	207.9	7.9	139.9	218.6	7.2	121.7	197.4	6.9	94.4	155.9	6.6
44.0	155.6	197.2	8.8	150.1	208.5	8.1	143.6	219.3	7.4	123.2	193.0	7.1	95.6	152.4	6.8
45.0	157.8	197.6	8.9	152.1	208.8	8.2	145.5	219.6	7.4	123.9	190.8	7.2	96.2	150.7	7.0
46.0	160.0	198.0	9.0	154.1	209.1	8.3	147.5	219.9	7.5	124.6	188.7	7.3	96.7	148.9	7.1
48.0	164.6	198.7	9.2	158.3	209.7	8.4	151.4	220.5	7.7	126.0	184.4	7.6	97.9	145.4	7.3
50.0	169.2	199.6	9.5	162.5	210.3	8.7	154.4	218.2	7.9	127.4	180.2	7.8	99.0	141.9	7.6
52.0	173.9	200.5	9.7	166.8	210.9	8.9	156.2	212.7	8.2	128.6	175.9	8.1	100.2	138.5	7.8
55.0	180.8	201.5	10.0	173.3	211.9	9.2	158.8	204.7	8.7	130.5	169.9	8.5	101.7	133.6	8.2

MODEL: YCAV0187E/V**E IPLV= 13.2****V IPLV= 15.1****AIR TEMPERATURE ON - CONDENSER (°F)**

LCWT (°F)	105.0			110.0			115.0			120.0			125.0		
	TONS	KW	EER	TONS	KW	EER	TONS	KW	EER	TONS	KW	EER	TONS	KW	EER
40.0	163.0	217.8	8.3	158.0	227.5	7.8	148.8	229.7	7.2	115.0	176.6	7.1	83.3	127.3	6.9
42.0	167.8	218.3	8.6	162.4	227.9	8.0	152.0	227.8	7.5	116.5	172.7	7.4	85.2	126.1	7.2
44.0	172.7	218.7	8.8	166.9	228.3	8.2	154.9	225.3	7.7	117.8	168.6	7.6	87.0	124.6	7.4
45.0	175.2	218.8	8.9	169.2	228.4	8.3	156.3	223.7	7.8	118.4	166.3	7.8	87.9	123.8	7.5
46.0	177.7	219.0	9.0	171.5	228.5	8.4	157.7	222.0	7.9	119.1	164.4	7.9	88.7	122.9	7.6
48.0	182.8	219.4	9.3	176.2	228.7	8.6	159.8	217.2	8.2	120.6	160.7	8.2	90.1	120.7	7.9
50.0	188.0	219.7	9.5	181.0	228.9	8.8	161.1	210.9	8.5	122.2	157.3	8.4	91.4	120.6	8.0
52.0	193.2	220.1	9.8	185.8	229.1	9.1	162.6	205.4	8.8	124.0	154.3	8.7	91.9	114.9	8.4
55.0	201.2	220.7	10.2	193.2	229.4	9.4	165.1	198.3	9.2	126.3	149.5	9.1	93.5	111.4	8.8

NOTES:

1. kW = Compressor Input Power
2. EER = Chiller EER (includes power from compressors, fans, and control panel's 0.8 KW)
3. LCWT = Leaving Chilled Water Temperature
4. Ratings based on 2.4 GPM cooler water per ton
5. Rated in accordance with ARI Standard 550/590.

High Efficiency Ratings – English - 60Hz

MODEL: YCAV0197E/V

E IPLV= 12.9

V IPLV= 14.9

AIR TEMPERATURE ON - CONDENSER (°F)

LCWT (°F)	75.0			80.0			85.0			90.0			95.0			100.0		
	TONS	KW	EER	TONS	KW	EER	TONS	KW	EER	TONS	KW	EER	TONS	KW	EER	TONS	KW	EER
40.0	189.8	153.1	13.4	188.2	165.6	12.4	186.4	179.5	11.4	184.5	194.4	10.5	182.5	210.2	9.6	180.1	227.8	8.8
42.0	195.8	154.3	13.7	194.1	166.4	12.7	192.2	180.0	11.7	190.3	194.8	10.8	188.1	210.6	9.9	185.6	228.4	9.1
44.0	201.9	155.8	14.0	200.1	167.5	13.0	198.2	180.8	12.0	196.1	195.4	11.1	193.9	211.0	10.2	191.3	228.9	9.3
45.0	205.0	156.6	14.2	203.2	168.2	13.2	201.3	181.3	12.2	199.1	195.7	11.2	196.8	211.2	10.4	194.2	229.1	9.5
46.0	208.1	157.6	14.3	206.3	168.8	13.3	204.3	181.8	12.3	202.2	196.0	11.4	199.8	211.5	10.5	197.1	229.4	9.6
48.0	214.5	159.6	14.6	212.6	170.4	13.6	210.6	182.9	12.7	208.3	196.9	11.7	205.8	212.2	10.8	203.0	230.0	9.9
50.0	221.0	162.1	14.8	219.1	172.3	13.9	216.9	184.3	12.9	214.5	198.1	12.0	212.0	213.1	11.1	209.0	230.9	10.1
52.0	227.7	164.8	15.0	225.7	174.5	14.2	223.4	186.1	13.2	221.0	199.4	12.3	218.3	214.2	11.3	215.2	231.7	10.4
55.0	237.9	169.6	15.3	235.8	178.3	14.5	233.4	189.1	13.6	230.8	201.8	12.7	228.0	216.1	11.7	223.7	231.3	10.8

MODEL: YCAV0207E/V

E IPLV= 13.4

V IPLV= 15.0

AIR TEMPERATURE ON - CONDENSER (°F)

LCWT (°F)	75.0			80.0			85.0			90.0			95.0			100.0		
	TONS	KW	EER	TONS	KW	EER	TONS	KW	EER	TONS	KW	EER	TONS	KW	EER	TONS	KW	EER
40.0	201.7	161.2	13.5	200.1	173.9	12.5	198.3	187.9	11.5	196.4	203.1	10.6	194.4	219.0	9.8	192.0	237.1	9.0
42.0	208.1	162.5	13.8	206.4	175.0	12.8	204.5	188.7	11.8	202.5	203.7	10.9	200.4	219.6	10.1	197.9	237.7	9.3
44.0	214.6	164.1	14.1	212.8	176.2	13.1	210.9	189.7	12.2	208.8	204.4	11.2	206.5	220.3	10.4	203.9	238.4	9.5
45.0	217.9	165.0	14.3	216.1	176.9	13.3	214.1	190.2	12.3	211.9	204.8	11.4	209.6	220.6	10.5	206.9	238.8	9.7
46.0	221.3	165.9	14.4	219.4	177.6	13.4	217.4	190.8	12.5	215.1	205.4	11.5	212.8	221.1	10.7	210.0	239.2	9.8
48.0	228.1	168.1	14.7	226.1	179.3	13.7	224.0	192.2	12.8	221.7	206.5	11.8	219.2	222.0	10.9	216.2	239.8	10.0
50.0	235.0	170.4	14.9	233.0	181.3	14.0	230.8	193.8	13.0	228.4	207.7	12.1	225.8	223.0	11.2	222.3	240.0	10.3
52.0	242.1	173.1	15.2	240.0	183.4	14.3	237.7	195.6	13.3	235.2	209.2	12.4	232.5	224.3	11.5	228.5	240.3	10.6
55.0	252.7	177.6	15.5	250.6	187.2	14.6	248.2	198.7	13.7	245.6	211.9	12.8	242.7	226.5	11.9	238.0	241.0	11.0

MODEL: YCAV0227E/V

E IPLV= 13.1

V IPLV= 15.0

AIR TEMPERATURE ON - CONDENSER (°F)

LCWT (°F)	75.0			80.0			85.0			90.0			95.0			100.0		
	TONS	KW	EER	TONS	KW	EER	TONS	KW	EER	TONS	KW	EER	TONS	KW	EER	TONS	KW	EER
40.0	209.5	167.1	13.4	207.9	179.8	12.5	206.1	193.4	11.6	204.2	208.1	10.7	202.1	223.5	10.0	199.8	241.0	9.2
42.0	216.1	168.5	13.7	214.5	181.0	12.8	212.6	194.6	11.9	210.6	209.1	11.0	208.4	224.5	10.2	205.9	242.0	9.4
44.0	222.9	170.1	14.1	221.2	182.3	13.1	219.2	195.8	12.2	217.1	210.2	11.3	214.9	225.6	10.5	212.2	243.1	9.7
45.0	226.4	171.0	14.2	224.6	183.1	13.3	222.6	196.4	12.3	220.4	210.8	11.5	218.1	226.1	10.6	215.4	243.7	9.8
46.0	229.8	171.9	14.4	228.0	183.9	13.4	226.0	197.1	12.5	223.8	211.4	11.6	221.4	226.8	10.8	218.6	244.2	9.9
48.0	236.9	173.9	14.7	235.0	185.6	13.7	232.9	198.7	12.8	230.6	212.8	11.9	228.1	228.0	11.0	225.2	245.5	10.2
50.0	244.0	176.0	14.9	242.1	187.5	14.0	239.9	200.3	13.1	237.6	214.2	12.2	235.0	229.3	11.3	232.0	246.8	10.4
52.0	251.1	178.3	15.2	249.2	189.5	14.3	247.0	202.1	13.3	244.6	215.9	12.4	242.0	230.8	11.6	238.9	248.2	10.7
55.0	262.1	182.1	15.6	260.1	192.9	14.6	257.8	205.1	13.7	255.3	218.6	12.8	252.5	233.3	12.0	249.2	250.5	11.0

NOTES:

1. kW = Compressor Input Power
2. EER = Chiller EER (includes power from compressors, fans, and control panels 0.8 kW)
3. LCWT = Leaving Chilled Water Temperature
4. Ratings based on 2.4 GPM cooler water per ton
5. Rated in accordance with ARI Standard 550/590-98 and are accordingly certified

MODEL: YCAV0197E/V										E IPLV= 12.9			V IPLV= 14.9		
AIR TEMPERATURE ON - CONDENSER (°F)															
LCWT (°F)	105.0			110.0			115.0			120.0			125.0		
	TONS	KW	EER	TONS	KW	EER	TONS	KW	EER	TONS	KW	EER	TONS	KW	EER
40.0	176.4	243.2	8.1	159.2	227.8	7.8	141.8	210.8	7.5	111.4	166.1	7.3	82.7	125.1	7.0
42.0	181.3	242.8	8.4	163.6	227.5	8.0	143.8	206.7	7.7	114.0	164.4	7.5	85.1	124.6	7.2
44.0	186.2	242.3	8.6	168.2	227.4	8.3	145.8	202.7	8.0	116.0	161.9	7.8	87.3	123.8	7.5
45.0	188.7	242.1	8.7	170.6	227.3	8.4	146.7	200.5	8.1	116.9	160.3	7.9	88.4	123.3	7.6
46.0	191.2	241.8	8.9	172.9	227.2	8.5	147.7	198.4	8.2	117.8	158.8	8.1	89.5	122.8	7.7
48.0	196.4	241.2	9.1	177.6	227.0	8.7	149.3	193.8	8.5	119.7	156.0	8.3	91.5	121.6	7.9
50.0	201.6	240.6	9.4	182.5	226.8	9.0	150.9	189.3	8.8	121.7	153.5	8.6	93.5	120.3	8.2
52.0	206.9	240.1	9.7	187.5	226.7	9.2	152.4	184.8	9.1	123.3	150.8	8.8	95.4	119.0	8.4
55.0	214.9	239.4	10.1	193.4	224.2	9.6	155.5	179.6	9.5	126.4	147.5	9.2	98.3	116.9	8.8

MODEL: YCAV0207E/V										E IPLV= 13.4			V IPLV= 15.0		
AIR TEMPERATURE ON - CONDENSER (°F)															
LCWT (°F)	105.0			110.0			115.0			120.0			125.0		
	TONS	KW	EER	TONS	KW	EER	TONS	KW	EER	TONS	KW	EER	TONS	KW	EER
40.0	188.3	252.6	8.3	182.0	262.6	7.8	0.0	0.0	0.0	142.9	221.4	7.2	109.6	170.4	7.0
42.0	193.7	252.8	8.6	186.9	262.5	8.0	163.7	236.0	7.7	146.7	220.5	7.4	112.5	169.4	7.2
44.0	199.2	253.0	8.8	191.9	262.3	8.2	168.6	236.5	7.9	150.3	219.1	7.6	114.9	167.4	7.4
45.0	202.0	253.0	8.9	194.5	262.2	8.3	171.2	236.8	8.0	151.9	217.9	7.7	116.1	166.4	7.5
46.0	204.8	253.1	9.1	197.1	262.0	8.4	173.9	237.3	8.2	152.9	215.7	7.8	117.2	165.2	7.7
48.0	210.6	253.2	9.3	202.3	261.6	8.7	179.4	238.3	8.4	154.6	210.8	8.1	118.9	161.8	7.9
50.0	216.2	252.8	9.6	207.7	261.1	8.9	185.4	240.0	8.6	156.2	206.0	8.4	120.8	159.0	8.2
52.0	221.8	252.4	9.8	213.1	260.7	9.2	192.0	242.6	8.8	157.9	201.2	8.6	122.7	156.4	8.4
55.0	230.5	251.9	10.2	221.4	260.0	9.5	202.7	247.5	9.1	160.1	194.0	9.0	126.1	153.3	8.8

MODEL: YCAV0227E/V										E IPLV= 13.1			V IPLV= 15.0		
AIR TEMPERATURE ON - CONDENSER (°F)															
LCWT (°F)	105.0			110.0			115.0			120.0			125.0		
	TONS	KW	EER	TONS	KW	EER	TONS	KW	EER	TONS	KW	EER	TONS	KW	EER
40.0	197.2	259.1	8.5	190.9	269.7	7.9	183.3	277.2	7.4	175.7	283.8	6.9	149.8	248.7	6.7
42.0	203.2	260.3	8.7	196.1	269.8	8.1	188.3	277.4	7.6	180.5	284.2	7.1	151.4	243.2	6.9
44.0	209.4	261.4	8.9	201.5	269.9	8.3	193.4	277.4	7.8	185.3	284.4	7.3	152.9	237.2	7.1
45.0	212.4	261.7	9.0	204.2	269.8	8.4	196.0	277.5	7.9	187.8	284.5	7.4	153.8	234.3	7.3
46.0	215.2	261.7	9.2	206.9	269.8	8.6	198.6	277.5	8.0	190.3	284.5	7.5	154.8	231.6	7.4
48.0	221.0	261.7	9.4	212.5	269.8	8.8	203.9	277.4	8.2	195.3	284.5	7.7	156.4	225.5	7.6
50.0	226.9	261.7	9.7	218.1	269.7	9.0	209.3	277.4	8.4	197.6	278.4	7.9	158.0	220.0	7.9
52.0	232.9	261.7	9.9	223.9	269.6	9.3	214.8	277.2	8.7	199.6	271.2	8.2	159.5	214.7	8.1
55.0	242.1	261.8	10.3	232.7	269.6	9.6	223.2	277.1	9.0	202.7	260.2	8.7	161.7	207.0	8.5

NOTES:

1. kW = Compressor Input Power
2. EER = Chiller EER (includes power from compressors, fans, and control panels 0.8 KW)
3. LCWT = Leaving Chilled Water Temperature
4. Ratings based on 2.4 GPM cooler water per ton
5. Rated in accordance with ARI Standard 550/590-98 and are accordingly certified

High Efficiency Ratings – English - 60Hz

MODEL: YCAV0247E/V																E_IPLV= 12.8			V_IPLV= 14.9		
AIR TEMPERATURE ON - CONDENSER (°F)																					
LCWT (°F)	75.0			80.0			85.0			90.0			95.0			100.0					
	TONS	KW	EER	TONS	KW	EER	TONS	KW	EER	TONS	KW	EER	TONS	KW	EER	TONS	KW	EER			
40.0	232.7	192.6	13.1	230.8	206.9	12.2	228.7	222.3	11.3	226.4	238.6	10.5	223.9	255.8	9.7	221.1	275.2	9.0			
42.0	240.0	194.4	13.4	238.0	208.6	12.5	235.8	223.9	11.6	233.4	240.2	10.8	230.8	257.3	10.0	227.9	276.8	9.2			
44.0	247.4	196.3	13.7	245.4	210.4	12.8	243.1	225.6	11.9	240.6	241.8	11.0	237.9	259.0	10.2	234.7	278.3	9.4			
45.0	251.2	197.4	13.9	249.1	211.4	12.9	246.8	226.5	12.0	244.2	242.7	11.1	241.4	259.9	10.3	238.1	278.9	9.6			
46.0	255.1	198.5	14.0	252.9	212.3	13.1	250.5	227.4	12.1	247.9	243.6	11.3	245.1	260.7	10.5	241.5	279.6	9.7			
48.0	262.8	200.8	14.3	260.6	214.5	13.3	258.1	229.4	12.4	255.4	245.4	11.5	252.4	262.6	10.7	248.4	280.9	9.9			
50.0	270.8	203.3	14.5	268.5	216.8	13.6	265.9	231.5	12.7	263.1	247.5	11.8	260.0	264.5	11.0	255.5	282.2	10.1			
52.0	278.9	205.9	14.8	276.5	219.2	13.9	273.8	233.8	12.9	270.9	249.6	12.0	267.7	266.6	11.2	262.8	283.6	10.4			
55.0	291.2	209.7	15.2	288.7	223.1	14.2	285.9	237.5	13.3	282.8	253.1	12.4	279.5	269.8	11.6	273.9	286.0	10.7			

MODEL: YCAV0267E/V																E_IPLV= 13.3			V_IPLV= 14.9		
AIR TEMPERATURE ON - CONDENSER (°F)																					
LCWT (°F)	75.0			80.0			85.0			90.0			95.0			100.0					
	TONS	KW	EER	TONS	KW	EER	TONS	KW	EER	TONS	KW	EER	TONS	KW	EER	TONS	KW	EER			
40.0	264.2	211.7	13.5	261.9	228.6	12.5	259.3	246.9	11.5	256.4	266.4	10.6	253.3	286.8	9.8	249.7	309.7	9.0			
42.0	272.6	213.3	13.8	270.3	229.9	12.8	267.6	248.0	11.8	264.6	267.4	10.9	261.3	287.9	10.1	257.6	310.9	9.2			
44.0	281.2	215.2	14.1	278.8	231.4	13.1	276.0	249.2	12.1	272.9	268.5	11.2	269.5	288.9	10.4	265.6	312.2	9.5			
45.0	285.5	216.3	14.3	283.1	232.3	13.3	280.3	249.9	12.3	277.2	269.1	11.4	273.7	289.5	10.5	269.7	312.7	9.6			
46.0	289.9	217.4	14.4	287.4	233.2	13.4	284.6	250.7	12.5	281.4	269.8	11.5	277.9	290.1	10.6	273.8	313.4	9.8			
48.0	298.8	219.9	14.7	296.3	235.3	13.7	293.4	252.4	12.8	290.1	271.2	11.8	286.5	291.4	10.9	282.2	314.7	10.0			
50.0	307.8	222.7	15.0	305.3	237.6	14.0	302.3	254.4	13.1	299.0	273.0	12.1	295.2	293.0	11.2	290.8	316.1	10.3			
52.0	317.0	225.8	15.3	314.5	240.3	14.3	311.5	256.6	13.3	308.0	274.9	12.4	304.2	294.7	11.5	299.6	317.8	10.5			
55.0	331.1	231.1	15.6	328.5	244.8	14.7	325.4	260.5	13.8	321.9	278.2	12.8	317.9	297.6	11.9	312.4	319.0	10.9			

MODEL: YCAV0287E/V																E_IPLV= 12.9			V_IPLV= 14.8		
AIR TEMPERATURE ON - CONDENSER (°F)																					
LCWT (°F)	75.0			80.0			85.0			90.0			95.0			100.0					
	TONS	KW	EER	TONS	KW	EER	TONS	KW	EER	TONS	KW	EER	TONS	KW	EER	TONS	KW	EER			
40.0	281.2	222.4	13.6	278.8	240.6	12.6	276.1	260.6	11.6	273.1	282.2	10.7	270.0	304.7	9.8	266.3	330.2	9.0			
42.0	290.1	224.2	14.0	287.6	241.7	12.9	284.8	261.4	11.9	281.7	282.7	11.0	278.4	305.4	10.1	274.6	331.0	9.3			
44.0	299.3	226.2	14.3	296.7	243.2	13.3	293.8	262.4	12.3	290.5	283.5	11.3	287.1	306.0	10.4	283.1	331.8	9.5			
45.0	303.9	227.4	14.4	301.3	244.2	13.4	298.3	263.1	12.4	295.0	284.0	11.5	291.5	306.4	10.5	287.4	332.2	9.6			
46.0	308.6	228.7	14.6	305.9	245.2	13.6	302.9	263.9	12.6	299.6	284.5	11.6	296.0	306.8	10.7	291.8	332.6	9.8			
48.0	318.1	231.7	14.9	315.4	247.4	13.9	312.2	265.5	12.9	308.8	285.7	11.9	305.0	307.8	11.0	300.7	333.6	10.1			
50.0	327.8	235.1	15.1	325.0	250.0	14.2	321.8	267.5	13.2	318.2	287.4	12.2	314.3	309.2	11.3	309.8	334.6	10.3			
52.0	337.8	239.0	15.3	334.8	253.2	14.4	331.5	269.9	13.5	327.8	289.4	12.5	323.8	310.7	11.6	319.1	335.8	10.6			
55.0	353.0	245.8	15.6	349.9	258.6	14.8	346.5	274.4	13.9	342.7	292.8	12.9	338.4	313.4	12.0	333.2	337.9	11.0			

NOTES:

1. kW = Compressor Input Power
2. EER = Chiller EER (includes power from compressors, fans, and control panels 0.8 kW)
3. LCWT = Leaving Chilled Water Temperature
4. Ratings based on 2.4 GPM cooler water per ton
5. Rated in accordance with ARI Standard 550/590-98 and are accordingly certified

MODEL: YCAV0247E/V										E IPLV= 12.8			V IPLV= 14.9		
AIR TEMPERATURE ON - CONDENSER (°F)															
LCWT (°F)	105.0			110.0			115.0			120.0			125.0		
	TONS	KW	EER	TONS	KW	EER	TONS	KW	EER	TONS	KW	EER	TONS	KW	EER
40.0	216.9	292.5	8.3	210.2	305.1	7.8	202.9	316.2	7.2	174.2	277.5	7.0	136.8	219.4	6.9
42.0	223.2	293.8	8.5	216.0	305.8	8.0	208.5	317.0	7.4	175.7	270.0	7.3	138.4	214.3	7.1
44.0	229.7	294.9	8.7	221.9	306.4	8.2	213.0	315.2	7.6	177.2	262.6	7.5	139.9	209.0	7.3
45.0	232.8	295.2	8.9	225.0	306.8	8.3	214.3	311.7	7.7	178.0	259.0	7.7	140.8	206.6	7.4
46.0	236.0	295.5	9.0	228.0	307.1	8.4	215.6	308.1	7.9	178.7	255.5	7.8	141.5	203.9	7.6
48.0	242.4	296.1	9.2	234.2	307.7	8.6	218.0	300.5	8.2	180.4	248.9	8.0	143.0	199.0	7.8
50.0	248.9	296.8	9.4	240.5	308.3	8.8	220.2	292.4	8.5	182.1	242.8	8.3	144.6	194.2	8.1
52.0	255.5	297.5	9.7	246.9	308.9	9.0	222.3	284.1	8.8	183.8	236.8	8.6	146.0	189.4	8.4
55.0	265.7	298.6	10.0	256.7	309.9	9.3	225.0	272.3	9.2	186.2	228.1	9.0	148.1	182.5	8.8

MODEL: YCAV0267E/V										E IPLV= 13.3			V IPLV= 14.9		
AIR TEMPERATURE ON - CONDENSER (°F)															
LCWT (°F)	105.0			110.0			115.0			120.0			125.0		
	TONS	KW	EER	TONS	KW	EER	TONS	KW	EER	TONS	KW	EER	TONS	KW	EER
40.0	244.9	331.1	8.3	234.7	343.0	7.7	224.5	353.9	7.1	199.4	328.6	6.8	150.4	246.8	6.7
42.0	251.8	331.4	8.5	241.3	343.4	7.9	230.7	354.6	7.3	202.3	322.8	7.0	153.6	243.9	6.9
44.0	258.9	331.4	8.8	247.9	343.6	8.1	237.1	355.1	7.5	205.2	316.5	7.2	156.6	240.5	7.1
45.0	262.4	331.4	8.9	251.3	343.7	8.2	240.3	355.3	7.6	206.6	313.1	7.4	158.1	238.7	7.2
46.0	266.0	331.5	9.0	254.7	343.8	8.3	243.5	355.5	7.7	207.8	309.5	7.5	159.5	236.8	7.4
48.0	273.3	331.4	9.2	261.7	343.8	8.5	250.2	355.6	7.9	210.2	302.8	7.7	161.8	232.1	7.6
50.0	280.7	331.3	9.5	268.8	343.8	8.8	256.9	355.8	8.1	212.7	296.3	8.0	164.0	227.3	7.8
52.0	288.2	331.3	9.7	276.0	343.8	9.0	263.8	355.8	8.3	215.1	289.8	8.2	166.4	223.0	8.1
55.0	299.8	331.4	10.1	287.1	343.7	9.4	269.5	345.4	8.8	218.5	280.0	8.6	170.2	217.4	8.5

MODEL: YCAV0287E/V										E IPLV= 12.9			V IPLV= 14.8		
AIR TEMPERATURE ON - CONDENSER (°F)															
LCWT (°F)	105.0			110.0			115.0			120.0			125.0		
	TONS	KW	EER	TONS	KW	EER	TONS	KW	EER	TONS	KW	EER	TONS	KW	EER
40.0	261.8	354.9	8.3	251.2	365.8	7.7	240.7	375.4	7.2	230.3	383.3	6.8	183.9	309.5	6.6
42.0	269.1	354.4	8.5	258.1	365.7	7.9	247.2	375.7	7.4	235.0	380.9	6.9	186.1	302.4	6.8
44.0	276.5	353.7	8.8	265.1	365.4	8.1	253.9	375.8	7.6	237.5	372.6	7.2	188.3	295.4	7.0
45.0	280.3	353.4	8.9	268.7	365.1	8.3	257.3	375.7	7.7	238.8	368.2	7.3	189.4	291.9	7.2
46.0	284.1	353.0	9.0	272.4	364.8	8.4	260.8	375.6	7.8	240.1	363.8	7.4	190.5	288.3	7.3
48.0	291.8	352.3	9.3	279.8	364.2	8.6	267.8	375.1	8.0	242.8	354.8	7.7	192.6	281.3	7.5
50.0	299.7	351.5	9.5	287.3	363.4	8.9	274.9	374.6	8.3	245.5	345.8	7.9	194.1	273.2	7.8
52.0	307.7	350.8	9.8	295.0	362.6	9.1	282.2	373.9	8.5	248.0	337.2	8.2	196.3	266.5	8.1
55.0	320.0	349.8	10.2	306.7	361.6	9.5	293.5	372.7	8.9	251.4	324.8	8.6	199.1	256.4	8.5

NOTES:

1. kW = Compressor Input Power
2. EER = Chiller EER (includes power from compressors, fans, and control panels 0.8 KW)
3. LCWT = Leaving Chilled Water Temperature
4. Ratings based on 2.4 GPM cooler water per ton
5. Rated in accordance with ARI Standard 550/590-98 and are accordingly certified

MODEL: YCAV0327E/V										E IPLV= 13.8			V IPLV= 14.8		
AIR TEMPERATURE ON - CONDENSER (°F)															
LCWT (°F)	105.0			110.0			115.0			120.0			125.0		
	TONS	KW	EER	TONS	KW	EER	TONS	KW	EER	TONS	KW	EER	TONS	KW	EER
40.0	283.6	382.0	8.3	273.3	395.7	7.8	262.0	405.9	7.3	236.6	383.5	6.9	186.7	305.6	6.7
42.0	291.6	382.1	8.6	280.6	395.6	8.0	269.0	406.3	7.5	239.1	375.4	7.1	189.0	298.6	7.0
44.0	299.7	382.2	8.8	288.1	395.4	8.2	276.1	406.4	7.6	241.8	366.8	7.4	191.2	291.6	7.2
45.0	303.9	382.1	8.9	292.0	395.2	8.3	279.7	406.4	7.7	243.1	362.4	7.5	192.4	288.2	7.3
46.0	308.1	382.2	9.0	295.9	395.0	8.4	283.4	406.3	7.9	244.5	357.9	7.6	193.5	284.7	7.5
48.0	316.6	382.0	9.3	303.7	394.5	8.6	290.9	406.0	8.1	247.3	349.0	7.9	195.5	277.3	7.7
50.0	325.0	381.4	9.6	311.7	393.8	8.9	298.5	405.5	8.3	250.0	340.3	8.2	197.1	269.7	8.0
52.0	333.5	380.8	9.8	319.9	393.2	9.1	304.6	401.2	8.5	252.4	331.7	8.4	199.3	263.0	8.2
55.0	346.6	380.1	10.2	332.4	392.2	9.5	309.4	385.0	9.0	255.9	319.9	8.9	202.3	253.4	8.7

MODEL: YCAV0357E/V										E IPLV= 12.2			V IPLV= 15.3		
AIR TEMPERATURE ON - CONDENSER (°F)															
LCWT (°F)	105.0			110.0			115.0			120.0			125.0		
	TONS	KW	EER	TONS	KW	EER	TONS	KW	EER	TONS	KW	EER	TONS	KW	EER
40.0	321.2	428.4	8.4	311.7	448.5	7.8	301.2	466.3	7.3	269.9	435.7	7.0	212.8	345.6	6.8
42.0	330.8	430.1	8.6	320.6	449.8	8.0	309.7	467.6	7.5	272.5	424.8	7.2	215.3	337.5	7.0
44.0	340.5	431.9	8.8	329.7	451.1	8.2	318.4	468.9	7.7	275.0	413.8	7.4	217.8	329.5	7.3
45.0	345.5	432.8	9.0	334.4	451.7	8.3	322.9	469.5	7.8	276.2	408.3	7.6	218.8	325.2	7.4
46.0	350.5	433.7	9.1	339.1	452.3	8.4	327.3	470.2	7.8	277.5	403.0	7.7	220.2	321.6	7.5
48.0	360.8	435.5	9.3	348.7	453.5	8.6	336.5	471.4	8.0	280.2	392.7	7.9	222.4	313.5	7.8
50.0	370.9	436.8	9.5	358.4	454.8	8.9	341.0	461.4	8.3	282.9	383.1	8.2	224.8	305.9	8.0
52.0	381.1	438.3	9.8	368.3	456.1	9.1	344.4	448.8	8.6	285.5	373.7	8.5	227.1	298.5	8.3
55.0	396.9	440.6	10.1	383.6	458.1	9.4	349.0	430.4	9.1	289.4	360.0	8.9	230.4	287.6	8.7

MODEL: YCAV0397E/V										E IPLV= 12.8			V IPLV= 15.0		
AIR TEMPERATURE ON - CONDENSER (°F)															
LCWT (°F)	105.0			110.0			115.0			120.0			125.0		
	TONS	KW	EER	TONS	KW	EER	TONS	KW	EER	TONS	KW	EER	TONS	KW	EER
40.0	345.6	473.3	8.2	331.9	487.7	7.6	310.8	482.9	7.2	282.4	459.7	6.9	229.1	378.7	6.7
42.0	355.2	472.8	8.4	341.1	487.6	7.9	0.0	0.0	0.0	290.0	458.7	7.1	235.7	378.1	6.9
44.0	365.1	472.0	8.7	350.4	487.3	8.1	327.3	481.4	7.6	297.7	457.6	7.3	241.9	376.2	7.1
45.0	370.1	471.5	8.8	355.1	487.0	8.2	331.8	481.4	7.7	301.7	457.0	7.4	245.0	375.1	7.2
46.0	375.2	471.0	8.9	360.0	486.7	8.3	336.4	481.5	7.8	305.7	456.4	7.5	248.0	373.8	7.3
48.0	385.3	470.1	9.2	369.8	485.8	8.5	346.1	482.0	8.1	313.6	455.0	7.7	253.9	370.9	7.5
50.0	395.8	469.0	9.4	379.7	484.9	8.8	356.2	482.9	8.3	321.6	453.1	7.9	258.8	365.9	7.8
52.0	406.3	468.1	9.7	389.9	483.8	9.0	366.6	484.3	8.5	329.2	450.5	8.2	261.4	356.4	8.0
55.0	422.1	466.7	10.1	405.5	482.3	9.4	383.8	487.9	8.8	334.5	435.3	8.6	265.2	342.9	8.5

NOTES:

1. kW = Compressor Input Power
2. EER = Chiller EER (includes power from compressors, fans, and control panels 0.8 kW)
3. LCWT = Leaving Chilled Water Temperature
4. Ratings based on 2.4 GPM cooler water per ton
5. Rated in accordance with ARI Standard 550/590-98 and are accordingly certified

High Efficiency Ratings – English - 60Hz

MODEL: YCAV0417E/V **E IPLV= 13.3** **V IPLV= 14.9**

AIR TEMPERATURE ON - CONDENSER (°F)																		
LCWT (°F)	75.0			80.0			85.0			90.0			95.0			100.0		
	TONS	KW	EER	TONS	KW	EER	TONS	KW	EER	TONS	KW	EER	TONS	KW	EER	TONS	KW	EER
40.0	408.0	322.7	13.6	404.6	348.1	12.6	400.8	376.0	11.6	396.8	406.2	10.7	392.6	438.1	9.9	387.7	474.2	9.1
42.0	421.0	325.4	13.9	417.4	350.2	12.9	413.5	377.6	12.0	409.3	407.4	11.1	404.7	439.3	10.2	399.6	475.5	9.4
44.0	434.3	328.7	14.3	430.5	352.7	13.3	426.4	379.7	12.3	422.0	409.0	11.4	417.3	440.6	10.5	411.8	477.0	9.6
45.0	441.1	330.5	14.4	437.2	354.1	13.4	433.0	380.8	12.4	428.5	409.9	11.5	423.6	441.4	10.6	418.0	477.7	9.7
46.0	447.9	332.4	14.6	444.0	355.7	13.6	439.7	382.0	12.6	435.0	411.0	11.7	430.1	442.3	10.8	424.3	478.5	9.9
48.0	461.8	336.8	14.8	457.7	359.2	13.9	453.3	384.7	12.9	448.4	413.2	12.0	443.2	444.2	11.1	436.8	479.6	10.1
50.0	476.0	341.7	15.1	471.8	363.2	14.1	467.1	388.1	13.2	462.0	415.8	12.2	456.6	446.4	11.3	449.2	480.1	10.4
52.0	490.6	347.2	15.3	486.1	367.7	14.4	481.2	391.8	13.5	476.0	418.9	12.5	470.3	448.9	11.6	461.9	480.7	10.7
55.0	512.9	356.8	15.6	508.2	375.5	14.8	503.0	398.2	13.9	497.4	424.4	12.9	491.4	453.6	12.0	481.3	482.2	11.1

MODEL: YCAV0477E/V **E IPLV= 13.2** **V IPLV= 14.9**

AIR TEMPERATURE ON - CONDENSER (°F)																		
LCWT (°F)	75.0			80.0			85.0			90.0			95.0			100.0		
	TONS	KW	EER	TONS	KW	EER	TONS	KW	EER	TONS	KW	EER	TONS	KW	EER	TONS	KW	EER
40.0	448.7	361.7	13.4	444.8	388.3	12.5	440.5	416.9	11.6	435.8	447.4	10.7	430.7	479.7	9.9	424.8	516.3	9.2
42.0	463.0	365.2	13.7	459.0	391.4	12.8	454.6	419.8	11.9	449.6	450.2	11.0	444.3	482.4	10.2	438.1	519.1	9.4
44.0	477.6	369.1	14.0	473.5	395.0	13.1	468.9	423.0	12.1	463.8	453.2	11.3	458.2	485.3	10.5	451.7	522.0	9.6
45.0	485.0	371.2	14.1	480.8	396.9	13.2	476.1	424.8	12.3	470.9	454.9	11.4	465.3	486.8	10.6	458.6	523.5	9.8
46.0	492.4	373.4	14.3	488.3	398.8	13.3	483.5	426.6	12.4	478.2	456.6	11.5	472.4	488.5	10.7	465.7	525.1	9.9
48.0	507.6	378.0	14.6	503.3	403.0	13.6	498.4	430.4	12.7	492.9	460.1	11.8	486.9	491.8	11.0	479.8	528.1	10.1
50.0	523.1	383.1	14.8	518.7	407.6	13.9	513.6	434.6	13.0	508.0	463.9	12.1	501.8	495.4	11.2	493.9	530.6	10.4
52.0	538.6	388.6	15.1	534.2	412.5	14.2	529.2	439.1	13.2	523.4	468.2	12.4	517.0	499.4	11.5	508.2	533.2	10.6
55.0	562.4	396.4	15.5	0.0	0.0	0.0	552.6	446.5	13.6	546.7	474.9	12.7	540.2	505.8	11.9	530.3	537.6	11.0

NOTES:

1. kW = Compressor Input Power
2. EER = Chiller EER (includes power from compressors, fans, and control panels 0.8 KW)
3. LCWT = Leaving Chilled Water Temperature
4. Ratings based on 2.4 GPM cooler water per ton
5. Rated in accordance with ARI Standard 550/590-98 and are accordingly certified

MODEL: YCAV0417E/V										E IPLV= 13.3			V IPLV= 14.9		
AIR TEMPERATURE ON - CONDENSER (°F)															
LCWT (°F)	105.0			110.0			115.0			120.0			125.0		
	TONS	KW	EER	TONS	KW	EER	TONS	KW	EER	TONS	KW	EER	TONS	KW	EER
40.0	379.8	505.2	8.4	366.8	525.2	7.8	351.7	539.2	7.3	317.6	509.6	7.0	250.5	406.2	6.8
42.0	390.8	505.6	8.6	376.7	525.0	8.0	361.1	539.6	7.5	321.0	498.7	7.2	253.5	396.9	7.0
44.0	402.0	506.0	8.9	386.9	524.6	8.3	370.8	539.6	7.7	324.6	487.1	7.4	256.6	387.6	7.3
45.0	407.7	506.1	9.0	392.0	524.3	8.4	375.7	539.5	7.8	326.5	481.2	7.6	258.1	383.0	7.4
46.0	413.5	506.3	9.1	397.3	524.0	8.5	380.6	539.3	7.9	328.4	475.3	7.7	259.6	378.4	7.5
48.0	425.1	506.4	9.4	407.9	523.2	8.7	390.8	538.8	8.1	332.1	463.5	8.0	262.3	368.6	7.8
50.0	436.5	505.5	9.7	418.7	522.3	9.0	401.1	538.1	8.4	335.8	452.1	8.2	264.5	358.4	8.0
52.0	448.0	504.7	9.9	429.8	521.4	9.2	409.3	532.2	8.6	338.9	440.6	8.5	267.3	349.6	8.3
55.0	465.7	503.8	10.3	446.7	520.0	9.6	415.7	510.5	9.1	343.7	425.1	8.9	271.5	336.8	8.7

MODEL: YCAV0477E/V										E IPLV= 13.2			V IPLV= 14.9		
AIR TEMPERATURE ON - CONDENSER (°F)															
LCWT (°F)	105.0			110.0			115.0			120.0			125.0		
	TONS	KW	EER	TONS	KW	EER	TONS	KW	EER	TONS	KW	EER	TONS	KW	EER
40.0	417.2	551.6	8.5	405.1	578.0	7.9	390.8	599.5	7.3	350.1	560.2	7.0	274.6	442.3	6.8
42.0	429.8	553.5	8.7	416.6	579.2	8.1	401.7	600.9	7.5	353.2	545.7	7.2	277.9	432.1	7.1
44.0	442.6	555.6	8.9	428.3	580.2	8.3	413.0	602.0	7.7	356.1	530.7	7.5	281.2	421.8	7.3
45.0	449.1	556.6	9.0	434.3	580.7	8.4	418.7	602.6	7.8	357.6	523.3	7.6	282.6	416.3	7.4
46.0	455.7	557.7	9.1	440.4	581.2	8.5	424.5	603.2	7.9	359.2	516.2	7.7	284.4	411.7	7.6
48.0	469.1	559.8	9.4	452.7	582.1	8.7	436.3	604.2	8.1	362.5	502.7	8.0	287.3	401.4	7.8
50.0	482.2	560.9	9.6	465.3	583.2	9.0	442.2	591.3	8.4	365.9	490.2	8.3	290.5	391.7	8.1
52.0	495.4	562.1	9.9	478.0	584.2	9.2	446.5	574.8	8.7	369.3	478.2	8.5	293.4	382.1	8.3
55.0	515.7	564.2	10.2	497.7	585.9	9.5	452.3	550.5	9.2	374.3	460.7	9.0	297.7	368.2	8.7

NOTES:

1. kW = Compressor Input Power
2. EER = Chiller EER (includes power from compressors, fans, and control panels 0.8 KW)
3. LCWT = Leaving Chilled Water Temperature
4. Ratings based on 2.4 GPM cooler water per ton
5. Rated in accordance with ARI Standard 550/590-98 and are accordingly certified

Standard Efficiency Ratings – SI - 60Hz

MODEL: YCAV0457S/P

AIR TEMPERATURE ON - CONDENSER (°C)

LCWT (°C)	25.0			30.0			35.0			40.0			45.0			50.0		
	KW _o	KW _i	COP	KW _o	KW _i	COP	KW _o	KW _i	COP	KW _o	KW _i	COP	KW _o	KW _i	COP	KW _o	KW _i	COP
5.0	1531.4	381.4	3.7	1506.6	435.1	3.2	1477.3	494.2	2.8	1435.5	558.4	2.4	1351.8	596.7	2.1	1101.4	517.9	2.0
6.0	1573.3	384.1	3.7	1547.7	437.5	3.3	1517.7	496.7	2.8	1471.4	559.4	2.5	1384.8	598.1	2.2	1111.2	505.9	2.1
7.0	1615.8	387.1	3.8	1589.5	440.2	3.3	1558.4	499.2	2.9	1507.8	560.5	2.5	1418.5	599.4	2.2	1121.7	494.9	2.1
8.0	1659.1	390.2	3.9	1632.0	442.9	3.4	1599.9	501.9	3.0	1544.5	561.5	2.6	1452.8	600.6	2.3	1132.6	484.1	2.2
9.0	1703.1	393.5	4.0	1675.2	445.9	3.5	1642.0	504.8	3.0	1581.8	562.5	2.6	1488.0	601.7	2.3	1143.3	473.5	2.2
10.0	1747.6	397.1	4.0	1719.0	449.1	3.5	1684.7	507.9	3.1	1619.6	563.5	2.7	1523.9	602.7	2.4	1154.0	463.0	2.3
11.0	1792.7	400.9	4.1	1763.6	452.4	3.6	1728.3	511.0	3.2	1658.0	564.4	2.8	1560.3	603.7	2.4	1164.4	452.7	2.4
12.0	1838.7	404.9	4.2	1808.7	456.1	3.7	1772.4	514.4	3.2	1696.5	565.6	2.8	1596.8	604.6	2.5	1174.7	442.6	2.5
13.0	1885.2	409.2	4.2	1854.5	459.8	3.7	1817.3	517.9	3.3	1736.0	566.7	2.9	1633.7	605.7	2.5	1184.9	432.7	2.5

MODEL: YCAV0477S/P

AIR TEMPERATURE ON - CONDENSER (°C)

LCWT (°C)	25.0			30.0			35.0			40.0			45.0			50.0		
	KW _o	KW _i	COP	KW _o	KW _i	COP	KW _o	KW _i	COP	KW _o	KW _i	COP	KW _o	KW _i	COP	KW _o	KW _i	COP
5.0	1643.2	409.8	3.7	1615.4	466.7	3.2	1583.4	529.2	2.8	1527.5	590.8	2.4	1436.2	630.7	2.2	1106.0	507.5	2.0
6.0	1689.4	413.0	3.8	1660.4	469.7	3.3	1627.0	532.2	2.9	1565.1	592.2	2.5	1470.8	632.3	2.2	1116.4	496.4	2.1
7.0	1736.6	416.4	3.8	1706.3	472.9	3.4	1671.3	535.6	2.9	1603.6	593.4	2.5	1506.3	633.7	2.3	1127.0	485.7	2.2
8.0	1784.6	420.2	3.9	1753.1	476.4	3.4	1716.6	539.1	3.0	1642.7	594.6	2.6	1542.5	635.0	2.3	1137.8	475.2	2.2
9.0	1833.5	424.2	4.0	1800.9	479.9	3.5	1762.8	542.7	3.0	1682.6	595.8	2.7	1579.5	636.3	2.4	1148.5	464.8	2.3
10.0	1882.7	428.4	4.1	1849.6	483.8	3.6	1810.1	546.3	3.1	1722.7	597.1	2.7	1616.8	637.6	2.4	1158.9	454.6	2.4
11.0	1932.4	432.8	4.1	1898.2	487.8	3.6	1858.2	550.2	3.2	1763.9	598.4	2.8	1634.7	624.6	2.5	1169.2	444.6	2.4
12.0	1982.9	437.6	4.2	1947.6	492.1	3.7	1906.2	554.2	3.2	1805.8	599.6	2.8	1649.9	609.6	2.6	1179.4	434.8	2.5
13.0	0.0	0.0	0.0	1997.9	496.5	3.7	1955.1	558.4	3.3	1848.3	601.0	2.9	1664.0	594.0	2.6	1189.4	425.1	2.6

NOTES:

1. kW_o = Unit kW Cooling Capacity Output
2. kW_i = Compressor kW Input
3. COP = Coefficient of Performance (includes condenser fan power)
4. LCWT = Leaving Chilled Water Temperature
5. Ratings based on 0.15 L/s cooler water per ton, and 0.018 (m² – °C)/kW

MODEL: YCAV0507S/P**AIR TEMPERATURE ON - CONDENSER (°C)**

LCWT (°C)	25.0			30.0			35.0			40.0			45.0			50.0		
	KW _o	KW _i	COP	KW _o	KW _i	COP	KW _o	KW _i	COP	KW _o	KW _i	COP	KW _o	KW _i	COP	KW _o	KW _i	COP
5.0	1715.8	428.5	3.7	1687.2	487.4	3.2	1654.3	552.1	2.8	1599.5	617.7	2.4	1512.4	664.4	2.2	1169.3	536.5	2.0
6.0	1764.0	431.9	3.8	1734.2	490.7	3.3	1699.7	555.4	2.9	1639.3	619.6	2.5	1549.1	666.5	2.2	1180.6	525.0	2.1
7.0	1813.2	435.6	3.8	1782.1	494.1	3.3	1746.0	559.1	2.9	1680.0	621.3	2.6	1586.8	668.5	2.2	1192.0	513.7	2.2
8.0	1863.2	439.5	3.9	1830.9	498.0	3.4	1793.3	562.8	3.0	1721.5	623.0	2.6	1625.4	670.3	2.3	1203.4	502.5	2.2
9.0	1914.2	443.8	4.0	1880.7	501.8	3.5	1841.5	566.8	3.0	1763.7	624.7	2.7	1664.7	672.1	2.3	1214.7	491.5	2.3
10.0	1965.1	448.1	4.0	1931.5	505.9	3.6	1890.7	570.7	3.1	1806.3	626.6	2.7	1704.5	674.0	2.4	1225.6	480.7	2.4
11.0	2016.4	452.6	4.1	1981.8	510.1	3.6	1940.9	574.9	3.2	1850.0	628.4	2.8	1722.9	659.7	2.5	1236.4	470.1	2.4
12.0	2068.5	457.6	4.2	2032.7	514.6	3.7	1990.6	579.1	3.2	1894.5	630.3	2.8	1738.8	643.6	2.6	1247.1	459.7	2.5
13.0	0.0	0.0	0.0	2084.7	519.2	3.7	2041.2	583.5	3.3	1939.6	632.2	2.9	1754.0	627.4	2.6	1257.5	449.4	2.6

MODEL: YCAV0527S/P**AIR TEMPERATURE ON - CONDENSER (°C)**

LCWT (°C)	25.0			30.0			35.0			40.0			45.0			50.0		
	KW _o	KW _i	COP	KW _o	KW _i	COP	KW _o	KW _i	COP	KW _o	KW _i	COP	KW _o	KW _i	COP	KW _o	KW _i	COP
5.0	1788.6	447.2	3.7	1759.3	508.1	3.2	1725.4	574.9	2.8	1671.7	644.4	2.4	1588.8	697.9	2.2	1232.8	565.4	2.0
6.0	1838.8	450.8	3.7	1808.2	511.6	3.3	1772.7	578.5	2.9	1713.6	646.8	2.5	1627.6	700.6	2.2	1245.1	553.4	2.1
7.0	1889.9	454.7	3.8	1858.1	515.3	3.3	1820.9	582.5	2.9	1756.5	649.0	2.6	1667.5	703.0	2.2	1257.3	541.5	2.2
8.0	1942.0	458.7	3.9	1908.8	519.4	3.4	1870.1	586.5	3.0	1800.4	651.2	2.6	1708.4	705.4	2.3	1269.2	529.7	2.2
9.0	1995.0	463.3	4.0	1960.7	523.5	3.5	1920.2	590.8	3.0	1845.0	653.5	2.7	1750.1	707.7	2.3	1281.1	518.1	2.3
10.0	2047.5	467.7	4.0	2013.5	527.8	3.5	1971.5	595.0	3.1	1890.1	656.0	2.7	1792.3	710.2	2.4	1292.6	506.6	2.4
11.0	2100.5	472.4	4.1	2065.4	532.2	3.6	2023.8	599.4	3.2	1936.3	658.3	2.8	1811.5	694.8	2.5	1303.9	495.4	2.4
12.0	2154.2	477.5	4.2	2118.0	537.0	3.7	2075.1	603.9	3.2	1983.3	660.7	2.8	1828.1	677.6	2.6	1315.1	484.4	2.5
13.0	0.0	0.0	0.0	2171.5	541.8	3.7	2127.3	608.5	3.3	2031.0	663.2	2.9	1844.2	660.8	2.6	1325.9	473.6	2.6

NOTES:

1. kW_o = Unit kW Cooling Capacity Output
2. kW_i = Compressor kW Input
3. COP = Coefficient of Performance (includes condenser fan power)
4. LCWT = Leaving Chilled Water Temperature
5. Ratings based on 0.15 L/s cooler water per ton, and 0.018 (m² – °C)/kW

MODEL: YCAV0197E/V**AIR TEMPERATURE ON - CONDENSER (°C)**

LCWT (°C)	25.0			30.0			35.0			40.0			45.0			50.0		
	KWo	KWi	COP	KWo	KWi	COP	KWo	KWi	COP	KWo	KWi	COP	KWo	KWi	COP	KWo	KWi	COP
5.0	675.6	158.4	3.9	664.4	182.6	3.3	651.5	210.4	2.9	634.0	241.4	2.5	534.4	219.7	2.3	353.8	148.2	2.1
6.0	694.6	159.5	3.9	683.0	183.1	3.4	669.6	210.7	2.9	649.6	241.0	2.5	546.5	218.8	2.3	361.5	147.1	2.2
7.0	714.1	160.7	4.0	702.0	183.8	3.5	688.0	211.1	3.0	665.3	240.6	2.6	558.5	217.6	2.4	369.2	145.9	2.3
8.0	733.9	162.2	4.1	721.3	184.7	3.6	706.8	211.7	3.1	681.5	240.0	2.7	569.5	215.9	2.5	376.5	144.6	2.3
9.0	754.1	163.9	4.2	741.1	185.7	3.7	726.0	212.3	3.2	697.9	239.5	2.7	577.7	212.7	2.5	383.4	143.0	2.4
10.0	774.6	165.9	4.2	761.2	186.9	3.7	745.5	213.1	3.2	714.6	239.0	2.8	582.3	208.0	2.6	390.1	141.4	2.5
11.0	795.6	168.1	4.3	781.7	188.3	3.8	765.5	214.0	3.3	731.5	238.5	2.9	587.0	203.4	2.7	396.2	139.5	2.5
12.0	816.9	170.6	4.4	802.5	190.1	3.9	785.8	215.1	3.4	748.7	238.0	2.9	591.0	198.7	2.7	401.3	137.2	2.6
13.0	838.5	173.4	4.4	823.7	191.9	4.0	806.5	216.4	3.5	765.9	237.7	3.0	596.3	194.6	2.8	403.9	133.9	2.7

MODEL: YCAV0207E/V**AIR TEMPERATURE ON - CONDENSER (°C)**

LCWT (°C)	25.0			30.0			35.0			40.0			45.0			50.0		
	KWo	KWi	COP	KWo	KWi	COP	KWo	KWi	COP	KWo	KWi	COP	KWo	KWi	COP	KWo	KWi	COP
5.0	718.2	166.7	3.9	706.8	191.3	3.4	693.9	219.3	2.9	675.0	250.0	2.5	593.2	242.9	2.3	455.9	197.9	2.1
6.0	738.5	167.9	4.0	726.6	192.0	3.5	713.1	219.9	3.0	692.4	250.2	2.6	702.9	301.2	2.2	463.5	195.3	2.2
7.0	759.2	169.2	4.0	746.8	192.9	3.5	732.7	220.5	3.1	710.1	250.3	2.6	721.1	302.8	2.2	470.4	192.3	2.2
8.0	780.3	170.8	4.1	767.4	193.9	3.6	752.7	221.3	3.1	728.2	250.4	2.7	739.6	304.2	2.3	476.8	189.0	2.3
9.0	801.8	172.6	4.2	788.5	195.0	3.7	773.1	222.1	3.2	746.7	250.5	2.8	0.0	0.0	0.0	484.4	186.3	2.4
10.0	823.7	174.5	4.3	809.9	196.4	3.8	793.9	223.0	3.3	765.5	250.6	2.8	694.4	255.0	2.5	492.3	183.8	2.4
11.0	846.0	176.7	4.3	831.6	198.0	3.8	815.1	224.1	3.4	784.3	250.7	2.9	717.3	258.3	2.6	500.4	181.4	2.5
12.0	868.2	179.1	4.4	853.7	199.7	3.9	836.7	225.4	3.4	802.6	250.5	3.0	739.5	261.1	2.7	508.6	179.2	2.6
13.0	890.8	181.8	4.5	875.8	201.6	4.0	858.4	226.9	3.5	821.2	250.2	3.1	760.7	263.2	2.7	516.9	177.0	2.6

MODEL: YCAV0227E/V**AIR TEMPERATURE ON - CONDENSER (°C)**

LCWT (°C)	25.0			30.0			35.0			40.0			45.0			50.0		
	KWo	KWi	COP	KWo	KWi	COP	KWo	KWi	COP	KWo	KWi	COP	KWo	KWi	COP	KWo	KWi	COP
5.0	746.1	172.7	3.9	734.9	196.8	3.4	721.8	224.0	3.0	705.9	256.0	2.6	664.2	274.4	2.3	610.7	283.6	2.0
6.0	767.2	173.9	4.0	755.5	197.9	3.5	741.9	224.9	3.0	725.2	257.0	2.6	680.5	274.4	2.3	616.1	278.3	2.1
7.0	788.7	175.4	4.0	776.6	199.0	3.5	762.4	225.9	3.1	744.9	258.1	2.7	696.9	274.5	2.4	621.7	272.8	2.1
8.0	810.6	176.9	4.1	798.1	200.2	3.6	783.3	227.0	3.2	765.1	259.1	2.7	713.7	274.5	2.4	627.4	267.1	2.2
9.0	833.0	178.6	4.2	820.0	201.5	3.7	804.6	228.1	3.2	785.3	260.0	2.8	730.9	274.4	2.5	633.4	261.2	2.3
10.0	855.3	180.4	4.3	842.2	203.0	3.8	826.4	229.3	3.3	804.2	260.0	2.9	748.4	274.3	2.5	639.5	255.1	2.3
11.0	877.9	182.4	4.3	864.4	204.6	3.9	848.4	230.6	3.4	823.1	260.1	2.9	766.1	274.2	2.6	645.6	249.0	2.4
12.0	900.9	184.5	4.4	887.0	206.2	3.9	870.4	232.1	3.5	842.6	260.1	3.0	784.0	274.2	2.7	651.6	243.0	2.5
13.0	924.2	186.8	4.5	909.9	208.1	4.0	892.9	233.6	3.5	861.9	260.2	3.1	802.3	274.1	2.7	657.4	237.3	2.6

NOTES:

1. kW_o = Unit kW Cooling Capacity Output
2. kW_i = Compressor kW Input
3. COP = Coefficient of Performance (includes condenser fan power)
4. LCWT = Leaving Chilled Water Temperature
5. Ratings based on 0.15 L/s cooler water per ton, and 0.018 (m² - °C)/kW

High Efficiency Ratings – SI - 60Hz

MODEL: YCAV0417E/V

AIR TEMPERATURE ON - CONDENSER (°C)

LCWT (°C)	25.0			30.0			35.0			40.0			45.0			50.0		
	KWo	KWi	COP	KWo	KWi	COP	KWo	KWi	COP	KWo	KWi	COP	KWo	KWi	COP	KWo	KWi	COP
5.0	1452.6	333.7	3.9	1428.8	382.7	3.4	1401.7	438.8	3.0	1362.1	500.1	2.5	1274.8	533.9	2.2	1028.9	462.5	2.1
6.0	1494.0	336.1	4.0	1469.2	384.1	3.5	1440.8	439.8	3.0	1397.3	500.4	2.6	1305.5	534.0	2.3	1038.8	452.3	2.1
7.0	1536.3	338.9	4.1	1510.3	386.0	3.6	1480.7	441.1	3.1	1433.3	500.6	2.7	1337.0	533.7	2.3	1049.8	442.7	2.2
8.0	1579.4	342.1	4.2	1552.4	388.0	3.7	1521.4	442.7	3.2	1470.2	500.9	2.7	1369.1	533.2	2.4	1060.1	433.5	2.3
9.0	1623.4	345.8	4.2	1595.3	390.5	3.7	1563.1	444.4	3.3	1507.7	501.1	2.8	1401.8	532.6	2.5	1070.0	424.4	2.3
10.0	1668.2	349.8	4.3	1639.1	393.3	3.8	1605.6	446.4	3.3	1546.0	501.3	2.9	1435.2	531.9	2.5	1079.9	415.3	2.4
11.0	1713.8	354.4	4.4	1683.7	396.6	3.9	1649.0	448.6	3.4	1583.9	501.4	2.9	1469.1	531.1	2.6	1089.6	406.3	2.5
12.0	1760.4	359.4	4.4	1729.1	400.1	4.0	1693.1	451.3	3.5	1621.3	500.9	3.0	1503.7	530.2	2.7	1099.1	397.5	2.5
13.0	1807.7	365.1	4.5	1775.5	404.1	4.0	1738.1	454.3	3.5	1659.3	500.4	3.1	1538.7	529.4	2.7	1108.3	388.8	2.6

NOTES:

1. kWo = Unit kW Cooling Capacity Output
2. KWi = Compressor kW Input
3. COP = Coefficient of Performance (includes condenser fan power)
4. LCWT = Leaving Chilled Water Temperature
5. Ratings based on 0.15 L/s cooler water per ton, and 0.018 (m² – °C)/kW

MODEL: YCAV0477E/V**AIR TEMPERATURE ON - CONDENSER (°C)**

LCWT (°C)	25.0			30.0			35.0			40.0			45.0			50.0		
	KW _o	KW _i	COP	KW _o	KW _i	COP	KW _o	KW _i	COP	KW _o	KW _i	COP	KW _o	KW _i	COP	KW _o	KW _i	COP
5.0	1597.6	373.7	3.9	1570.3	424.2	3.4	1538.2	481.1	3.0	1495.8	546.1	2.6	1413.8	591.6	2.2	1125.7	503.2	2.1
6.0	1643.1	376.9	3.9	1615.1	426.9	3.5	1581.7	483.5	3.0	1536.0	547.9	2.6	1449.6	592.7	2.3	1136.4	492.3	2.1
7.0	1689.4	380.3	4.0	1660.6	429.9	3.5	1626.1	486.1	3.1	1577.3	549.7	2.7	1486.1	593.7	2.3	1147.4	481.8	2.2
8.0	1736.6	384.1	4.1	1707.0	433.2	3.6	1671.3	489.2	3.2	1619.3	551.7	2.7	1523.5	594.6	2.4	1158.3	471.4	2.3
9.0	1784.6	388.2	4.2	1754.3	436.6	3.7	1717.5	492.2	3.2	1662.2	553.6	2.8	1561.5	595.5	2.5	1169.1	461.2	2.3
10.0	1833.5	392.5	4.2	1802.4	440.3	3.8	1764.6	495.4	3.3	1705.8	555.7	2.9	1600.4	596.4	2.5	1179.6	451.1	2.4
11.0	1882.7	397.2	4.3	1851.4	444.2	3.8	1812.5	499.0	3.4	1749.4	557.6	2.9	1639.8	597.3	2.6	1190.0	441.1	2.5
12.0	1932.2	402.3	4.4	1900.6	448.5	3.9	1861.4	502.7	3.4	1792.3	558.8	3.0	1680.1	598.2	2.6	1200.2	431.4	2.5
13.0	1983.1	406.5	4.4	1950.3	453.0	4.0	1910.3	506.7	3.5	1835.9	560.2	3.1	1698.7	585.4	2.7	1210.3	421.8	2.6

NOTES:

1. kW_o = Unit kW Cooling Capacity Output
2. kW_i = Compressor kW Input
3. COP = Coefficient of Performance (includes condenser fan power)
4. LCWT = Leaving Chilled Water Temperature
5. Ratings based on 0.15 L/s cooler water per ton, and 0.018 (m² – °C)/kW

Standard Efficiency Ratings – SI - 50Hz

MODEL: YCAV1549S/P

AIR TEMPERATURE ON - CONDENSER (°C)

LCWT (°C)	25.0			30.0			35.0			40.0			45.0			50.0		
	KWo	KWi	COP	KWo	KWi	COP	KWo	KWi	COP	KWo	KWi	COP	KWo	KWi	COP	KWo	KWi	COP
5.0	1427.5	355.9	3.7	1405.1	409.1	3.2	1379.7	467.6	2.8	1334.4	525.5	2.4	1241.7	551.3	2.1	1002.3	473.0	2.0
6.0	1466.5	358.2	3.7	1443.0	410.8	3.3	1416.5	469.3	2.8	1366.5	525.7	2.4	1271.1	552.0	2.2	1011.5	462.8	2.0
7.0	1506.2	360.5	3.8	1481.7	412.6	3.3	1453.9	471.1	2.9	1399.2	525.6	2.5	1300.9	552.5	2.2	1022.0	452.9	2.1
8.0	1546.5	363.2	3.9	1521.1	414.7	3.4	1492.1	473.0	3.0	1431.7	525.4	2.6	1331.6	552.7	2.3	1032.3	443.1	2.2
9.0	1587.6	366.0	4.0	1561.2	416.9	3.5	1530.9	475.3	3.0	1464.8	525.1	2.6	1362.9	552.7	2.3	1042.2	433.8	2.2
10.0	1629.3	369.4	4.0	1602.0	419.4	3.5	1570.5	477.4	3.1	1498.3	524.8	2.7	1394.9	552.5	2.4	1052.1	424.6	2.3
11.0	1671.8	372.9	4.1	1643.5	422.2	3.6	1610.8	479.8	3.1	1532.3	524.5	2.8	1426.7	552.3	2.4	1061.6	415.4	2.4
12.0	1714.9	376.7	4.2	1685.5	425.4	3.7	1651.8	482.3	3.2	1566.4	524.2	2.8	1458.7	552.0	2.5	1071.3	406.3	2.4
13.0	1758.7	380.8	4.2	1728.3	428.7	3.7	1693.4	485.1	3.3	1601.3	523.9	2.9	1491.2	551.5	2.6	1080.8	397.4	2.5

MODEL: YCAV1649S/P

AIR TEMPERATURE ON - CONDENSER (°C)

LCWT (°C)	25.0			30.0			35.0			40.0			45.0			50.0		
	KWo	KWi	COP	KWo	KWi	COP	KWo	KWi	COP	KWo	KWi	COP	KWo	KWi	COP	KWo	KWi	COP
5.0	1531.4	381.4	3.7	1506.6	435.1	3.2	1477.3	494.2	2.8	1435.5	558.4	2.4	1351.8	596.7	2.1	1101.4	517.9	2.0
6.0	1573.3	384.1	3.7	1547.7	437.5	3.3	1517.7	496.7	2.8	1471.4	559.4	2.5	1384.8	598.1	2.2	1111.2	505.9	2.1
7.0	1615.8	387.1	3.8	1589.5	440.2	3.3	1558.4	499.2	2.9	1507.8	560.5	2.5	1418.5	599.4	2.2	1121.7	494.9	2.1
8.0	1659.1	390.2	3.9	1632.0	442.9	3.4	1599.9	501.9	3.0	1544.5	561.5	2.6	1452.8	600.6	2.3	1132.6	484.1	2.2
9.0	1703.1	393.5	4.0	1675.2	445.9	3.5	1642.0	504.8	3.0	1581.8	562.5	2.6	1488.0	601.7	2.3	1143.3	473.5	2.2
10.0	1747.6	397.1	4.0	1719.0	449.1	3.5	1684.7	507.9	3.1	1619.6	563.5	2.7	1523.9	602.7	2.4	1154.0	463.0	2.3
11.0	1792.7	400.9	4.1	1763.6	452.4	3.6	1728.3	511.0	3.2	1658.0	564.4	2.8	1560.3	603.7	2.4	1164.4	452.7	2.4
12.0	1838.7	404.9	4.2	1808.7	456.1	3.7	1772.4	514.4	3.2	1696.5	565.6	2.8	1596.8	604.6	2.5	1174.7	442.6	2.5
13.0	1885.2	409.2	4.2	1854.5	459.8	3.7	1817.3	517.9	3.3	1736.0	566.7	2.9	1633.7	605.7	2.5	1184.9	432.7	2.5

MODEL: YCAV1739S/P

AIR TEMPERATURE ON - CONDENSER (°C)

LCWT (°C)	25.0			30.0			35.0			40.0			45.0			50.0		
	KWo	KWi	COP	KWo	KWi	COP	KWo	KWi	COP	KWo	KWi	COP	KWo	KWi	COP	KWo	KWi	COP
5.0	1643.2	409.8	3.7	1615.4	466.7	3.2	1583.4	529.2	2.8	1527.5	590.8	2.4	1436.2	630.7	2.2	1106.0	507.5	2.0
6.0	1689.4	413.0	3.8	1660.4	469.7	3.3	1627.0	532.2	2.9	1565.1	592.2	2.5	1470.8	632.3	2.2	1116.4	496.4	2.1
7.0	1736.6	416.4	3.8	1706.3	472.9	3.4	1671.3	535.6	2.9	1603.6	593.4	2.5	1506.3	633.7	2.3	1127.0	485.7	2.2
8.0	1784.6	420.2	3.9	1753.1	476.4	3.4	1716.6	539.1	3.0	1642.7	594.6	2.6	1542.5	635.0	2.3	1137.8	475.2	2.2
9.0	1833.5	424.2	4.0	1800.9	479.9	3.5	1762.8	542.7	3.0	1682.6	595.8	2.7	1579.5	636.3	2.4	1148.5	464.8	2.3
10.0	1882.7	428.4	4.1	1849.6	483.8	3.6	1810.1	546.3	3.1	1722.7	597.1	2.7	1616.8	637.6	2.4	1158.9	454.6	2.4
11.0	1932.4	432.8	4.1	1898.2	487.8	3.6	1858.2	550.2	3.2	1763.9	598.4	2.8	1634.7	624.6	2.5	1169.2	444.6	2.4
12.0	1982.9	437.6	4.2	1947.6	492.1	3.7	1906.2	554.2	3.2	1805.8	599.6	2.8	1649.9	609.6	2.6	1179.4	434.8	2.5
13.0	0.0	0.0	0.0	1997.9	496.5	3.7	1955.1	558.4	3.3	1848.3	601.0	2.9	1664.0	594.0	2.6	1189.4	425.1	2.6

NOTES:

1. kW_o = Unit kW Cooling Capacity Output
2. kW_i = Compressor kW Input
3. COP = Coefficient of Performance (includes condenser fan power)
4. LCWT = Leaving Chilled Water Temperature
5. Ratings based on 0.15 L/s cooler water per ton, and 0.018 (m² – °C)/kW

MODEL: YCAV1829S/P**AIR TEMPERATURE ON - CONDENSER (°C)**

LCWT (°C)	25.0			30.0			35.0			40.0			45.0			50.0		
	KW _o	KW _i	COP	KW _o	KW _i	COP	KW _o	KW _i	COP	KW _o	KW _i	COP	KW _o	KW _i	COP	KW _o	KW _i	COP
5.0	1715.8	428.5	3.7	1687.2	487.4	3.2	1654.3	552.1	2.8	1599.5	617.7	2.4	1512.4	664.4	2.2	1169.3	536.5	2.0
6.0	1764.0	431.9	3.8	1734.2	490.7	3.3	1699.7	555.4	2.9	1639.3	619.6	2.5	1549.1	666.5	2.2	1180.6	525.0	2.1
7.0	1813.2	435.6	3.8	1782.1	494.1	3.3	1746.0	559.1	2.9	1680.0	621.3	2.6	1586.8	668.5	2.2	1192.0	513.7	2.2
8.0	1863.2	439.5	3.9	1830.9	498.0	3.4	1793.3	562.8	3.0	1721.5	623.0	2.6	1625.4	670.3	2.3	1203.4	502.5	2.2
9.0	1914.2	443.8	4.0	1880.7	501.8	3.5	1841.5	566.8	3.0	1763.7	624.7	2.7	1664.7	672.1	2.3	1214.7	491.5	2.3
10.0	1965.1	448.1	4.0	1931.5	505.9	3.6	1890.7	570.7	3.1	1806.3	626.6	2.7	1704.5	674.0	2.4	1225.6	480.7	2.4
11.0	2016.4	452.6	4.1	1981.8	510.1	3.6	1940.9	574.9	3.2	1850.0	628.4	2.8	1722.9	659.7	2.5	1236.4	470.1	2.4
12.0	2068.5	457.6	4.2	2032.7	514.6	3.7	1990.6	579.1	3.2	1894.5	630.3	2.8	1738.8	643.6	2.6	1247.1	459.7	2.5
13.0	0.0	0.0	0.0	2084.7	519.2	3.7	2041.2	583.5	3.3	1939.6	632.2	2.9	1754.0	627.4	2.6	1257.5	449.4	2.6

MODEL: YCAV1909S/P**AIR TEMPERATURE ON - CONDENSER (°C)**

LCWT (°C)	25.0			30.0			35.0			40.0			45.0			50.0		
	KW _o	KW _i	COP	KW _o	KW _i	COP	KW _o	KW _i	COP	KW _o	KW _i	COP	KW _o	KW _i	COP	KW _o	KW _i	COP
5.0	1788.6	447.2	3.7	1759.3	508.1	3.2	1725.4	574.9	2.8	1671.7	644.4	2.4	1588.8	697.9	2.2	1232.8	565.4	2.0
6.0	1838.8	450.8	3.7	1808.2	511.6	3.3	1772.7	578.5	2.9	1713.6	646.8	2.5	1627.6	700.6	2.2	1245.1	553.4	2.1
7.0	1889.9	454.7	3.8	1858.1	515.3	3.3	1820.9	582.5	2.9	1756.5	649.0	2.6	1667.5	703.0	2.2	1257.3	541.5	2.2
8.0	1942.0	458.7	3.9	1908.8	519.4	3.4	1870.1	586.5	3.0	1800.4	651.2	2.6	1708.4	705.4	2.3	1269.2	529.7	2.2
9.0	1995.0	463.3	4.0	1960.7	523.5	3.5	1920.2	590.8	3.0	1845.0	653.5	2.7	1750.1	707.7	2.3	1281.1	518.1	2.3
10.0	2047.5	467.7	4.0	2013.5	527.8	3.5	1971.5	595.0	3.1	1890.1	656.0	2.7	1792.3	710.2	2.4	1292.6	506.6	2.4
11.0	2100.5	472.4	4.1	2065.4	532.2	3.6	2023.8	599.4	3.2	1936.3	658.3	2.8	1811.5	694.8	2.5	1303.9	495.4	2.4
12.0	2154.2	477.5	4.2	2118.0	537.0	3.7	2075.1	603.9	3.2	1983.3	660.7	2.8	1828.1	677.6	2.6	1315.1	484.4	2.5
13.0	0.0	0.0	0.0	2171.5	541.8	3.7	2127.3	608.5	3.3	2031.0	663.2	2.9	1844.2	660.8	2.6	1325.9	473.6	2.6

NOTES:

1. kW_o = Unit kW Cooling Capacity Output
2. kW_i = Compressor kW Input
3. COP = Coefficient of Performance (includes condenser fan power)
4. LCWT = Leaving Chilled Water Temperature
5. Ratings based on 0.15 L/s cooler water per ton, and 0.018 (m² – °C)/kW

NOTES:

1. kW_o = Unit kW Cooling Capacity Output
2. kW_i = Compressor kW Input
3. COP = Coefficient of Performance (includes condenser fan power)
4. LCWT = Leaving Chilled Water Temperature
5. Ratings based on 0.15 L/s cooler water per ton, and 0.018 (m² – °C)/kW

Physical Data (English - Standard Efficiency)

Refrigerant R-134a	STANDARD EFFICIENCY						
	MODEL NUMBER (YCAV S/P)						
General Unit Data	YCAV0157	YCAV0177	YCAV0187	YCAV0207	YCAV0227	YCAV0247	YCAV0267
Number of Independent Refrigerant Circuits	2	2	2	2	2	2	2
Refrigerant Charge, R-134a, Ckt.-1/Ckt.-2, lbs	162/162	170/170	185/170	192/175	192/192	230/195	230/230
Oil Charge, Ckt.-1/Ckt.-2, gal.	5/5	5/5	5/5	5/5	5/5	5/5	5/5
Compressors, Semi-hermetic Screw Qty per Chiller	2	2	2	2	2	2	2
Condensers, High Efficiency Fin/Tube with Integral Subcooler							
Total Chiller Coil Face Area, ft ²	235	235	264	264	293	323	352
Number of Rows	3	3	3	3	3	3	3
Fins per Inch	17	17	17	17	17	17	17
Condenser Fans							
Number, Ckt.-1/Ckt.-2	4/4	4/4	5/4	5/4	5/5	6/5	6/6
Low Sound Fans							
Fan Motor, HP	2	2	2	2	2	2	2
Fan & Motor Speed, revs./min.	1140	1140	1140	1140	1140	1140	1140
Fan Diameter, inches	35.4	35.4	35.4	35.4	35.4	35.4	35.4
Fan Tip Speed, ft./min.	10575	10575	10575	10575	10575	10575	10575
Total Chiller Airflow, cfm	104000	104000	117000	117000	130000	143000	156000
Ultra Quiet Fans							
Fan Motor, HP	2	2	2	2	2	2	2
Fan & Motor Speed, revs./min.	838	838	838	838	838	838	838
Fan Diameter, inches	35.4	35.4	35.4	35.4	35.4	35.4	35.4
Fan Tip Speed, ft./min.	7774	7774	7774	7774	7774	7774	7774
Total Chiller Airflow, cfm	104000	104000	117000	117000	130000	143000	156000
Evaporator, Direct Expansion							
Water Volume, gals.	67.0	95.0	95.0	140.0	140.0	140.0	140.0
Maximum Water Side Pressure, PSIG ¹	150	150	150	150	150	150	150
Maximum Refrigerant Side Pressure, PSIG	235	235	235	235	235	235	235
Minimum Chilled Water Flow Rate, gpm	140	160	160	180	180	180	180
Maximum Chilled Water Flow Rate, gpm	675	750	750	800	800	800	800
Water Connections, inches	8	10	10	10	10	10	10

Contact your nearest York Sales Office for weight data.

¹ Optional 300 PSIG Waterside available

Physical Data (English - High Efficiency)

FORM 201.21-EG1 (607)

Refrigerant R-134a	HIGH EFFICIENCY						
	MODEL NUMBER (YCAV E/V)						
	YCAV0157	YCAV0177	YCAV0187	YCAV0197	YCAV0207	YCAV0227	YCAV0247
General Unit Data							
Number of Independent Refrigerant Circuits	2	2	2	2	2	2	2
Refrigerant Charge, R-134a, Ckt.-1/Ckt.-2, lbs	170/170	185/170	185/185	192/192	225/192	225/225	230/230
Oil Charge, Ckt.-1/Ckt.-2, gal.	5/5	5/5	5/5	5/5	5/5	5/5	5/5
Compressors, Semihermetic Screw Qty per Chiller	2	2	2	2	2	2	2
Condensers, High Efficiency Fin/Tube with Integral Subcooler							
Total Chiller Coil Face Area, ft ²	235	264	293	293	323	352	352
Number of Rows	3	3	3	3	3	3	3
Fins per Inch	17	17	17	17	17	17	17
Condenser Fans							
Number, Ckt.-1/Ckt.-2	4/4	5/4	5/5	5/5	6/5	6/6	6/6
Low Sound Fans							
Fan Motor, HP	2	2	2	2	2	2	2
Fan & Motor Speed, revs./min.	1140	1140	1140	1140	1140	1140	1140
Fan Diameter, inches	35.4	35.4	35.4	35.4	35.4	35.4	35.4
Fan Tip Speed, ft./min.	10575	10575	10575	10575	10575	10575	10575
Total Chiller Airflow, cfm	104000	117000	130000	130000	143000	156000	156000
Ultra Quiet Fans							
Fan Motor, HP	2	2	2	2	2	2	2
Fan & Motor Speed, revs./min.	838	838	838	838	838	838	838
Fan Diameter, inches	35.4	35.4	35.4	35.4	35.4	35.4	35.4
Fan Tip Speed, ft./min.	7774	7774	7774	7774	7774	7774	7774
Total Chiller Airflow, cfm	104000	117000	130000	130000	143000	156000	156000
Evaporator, Direct Expansion							
Water Volume, gals.	95.0	95.0	95.0	110.0	110.0	110.0	140.0
Maximum Water Side Pressure, PSIG ¹	150	150	150	150	150	150	150
Maximum Refrigerant Side Pressure, PSIG	235	235	235	235	235	235	235
Minimum Chilled Water Flow Rate, gpm	160	160	160	180	180	180	180
Maximum Chilled Water Flow Rate, gpm	750	750	750	750	750	750	800
Water Connections, inches	10	10	10	10	10	10	10

Contact your nearest York Sales Office for weight data.

¹ Optional 300 PSIG Waterside available

Physical Data (English - Standard Efficiency)

Refrigerant R-134a	STANDARD EFFICIENCY									
	MODEL NUMBER (YCAV ___ S/P)									
	60Hz	YCAV0287	YCAV0307	YCAV0357	YCAV0397	YCAV0417	YCAV0457	YCAV0477	YCAV0507	YCAV0527
50Hz	-	-	-	-	-	YCAV1549	YCAV1649	YCAV1739	YCAV1829	YCAV1909
General Unit Data										
Number of Independent Refrigerant Circuits	3	3	3	3	4	4	4	4	4	4
Refrigerant Charge, R-134a, Ckt.-1/Ckt.-2, lbs	185/170/170	185/185/170	185/185/230	230/230/230	185/185/ 185/185	230/185/ 185/185	230/230/ 185/185	230/230/ 185/185	230/230/ 185/185	230/230/ 230/230
Oil Charge, Ckt.-1/Ckt.-2, gal.	5/4/4	5/4/4	5/5/5	5/5/5	5/5/5/5	5/5/5/5	5/5/5/5	5/5/5/5	5/5/5/5	5/5/5/5
Glycol Charge (43% concentration), gal	5.4	5.5	6.0	6.3	9.2	9.3	9.4	9.8	9.9	
Comp.s, Semihhermetic Screw										
Quantity per Chiller	3	3	3	3	4	4	4	4	4	4
Condensers, High Efficiency Fin/Tube with Integral Subcooler										
Total Chiller Coil Face Area, ft ²	381	411	469	528	587	616	645	645	704	
Number of Rows	3	3	3	3	3	3	3	3	3	3
Fins per Inch	17	17	17	17	17	17	17	17	17	17
Condenser Fans										
Number, Ckt.-1/Ckt.-2	5/4/4	5/4/4	5/5/6	6/6/6	5/5/5/5	6/5/5/5	6/5/5/5	6/6/5/6	6/6/6/6	
Low Noise Fans										
Fan Motor, HP/kW	2/1.8	2/1.8	2/1.8	2/1.8	2/1.8	2/1.8	2/1.8	2/1.8	2/1.8	2/1.8
Fan & Motor Speed, revs./min.	1140	1140	1140	1140	1140	1140	1140	1140	1140	1140
Fan Diameter, inches	35.4	35.4	35.4	35.4	35.4	35.4	35.4	35.4	35.4	35.4
Fan Tip Speed, ft./min.	10575	10575	10575	10575	10575	10575	10575	10575	10575	10575
Total Chiller Airflow, cfm	169000	182000	208000	234000	260000	273000	286000	286000	312000	
Ultra Quiet Fans										
Fan Motor, HP/kW	2/1.50	2/1.50	2/1.50	2/1.50	2/1.50	2/1.50	2/1.50	2/1.50	2/1.50	2/1.50
Fan & Motor Speed, revs./min.	838	838	838	838	838	838	838	838	838	838
Fan Diameter, inches	35.4	35.4	35.4	35.4	35.4	35.4	35.4	35.4	35.4	35.4
Fan Tip Speed, ft./min.	7774	7774	7774	7774	7774	7774	7774	7774	7774	7774
Total Chiller Airflow, cfm	169000	182000	208000	234000	260000	273000	286000	286000	312000	
Evaporator, Direct Expansion										
Water Volume, gals.	202.0	236.0	236.0	236.0	266.0	266.0	318.0	318.0	318.0	
Maximum Water Side Pressure, PSIG	150	150	150	150	150	150	150	150	150	150
Maximum Refrigerant Side Pressure, PSIG	235	235	235	235	235	235	235	235	235	235
Minimum Chilled Water Flow Rate, gpm	250	300	300	300	350	350	400	400	400	400
Maximum Chilled Water Flow Rate, gpm	1200	1200	1200	1200	1250	1250	1400	1400	1400	1400
Water Connections, inches	10	10	10	10	10	10	10	10	10	10

Contact your nearest York Sales Office for weight data.

Physical Data (English - High Efficiency)

FORM 201.21-EG1 (607)

Refrigerant R-134a	HIGH EFFICIENCY							
	MODEL NUMBER (YCAV ___ E/V)							
	60Hz	YCAV0267	YCAV0287	YCAV0327	YCAV0357	YCAV0397	YCAV0417	YCAV0477
	50Hz	-	-	-	-	YCAV1429	YCAV1549	YCAV1739
General Unit Data								
Number of Independent Refrigerant Circuits	3	3	3	3	4	4	4	4
Refrigerant Charge, R-134a, Ckt.-1/Ckt.-2, lbs	185/185/170	185/185/230	185/185/230	230/230/230	185/185/185/185	230/230/185/185	230/230/230/230	230/230/230/230
Oil Charge, Ckt.-1/Ckt.-2, gal.	5/5/4	5/5/5	5/5/5	5/5/5	5/5/5/5	5/5/5/5	5/5/5/5	5/5/5/5
Glycol Charge (43% concentration), gal	5.5	5.7	6.0	6.3	9.2	9.4	9.6	9.6
Comp.s, Semihermetic Screw								
Quantity per Chiller	3	3	3	3	4	4	4	4
Condensers, High Efficiency Fin/Tube with Integral Subcooler								
Total Chiller Coil Face Area, ft ²	411	469	469	528	569	645	704	704
Number of Rows	3	3	3	3	3	3	3	3
Fins per Inch	17	17	17	17	17	17	17	17
Condenser Fans								
Number, Ckt.-1/Ckt.-2	5/5/4	5/5/6	5/5/6	6/6/6	5/5/5/5	6/6/5/5	6/6/6/6	6/6/6/6
Low Noise Fans								
Fan Motor, HP/kW	2/1.8	2/1.8	2/1.8	2/1.8	2/1.8	2/1.8	2/1.8	2/1.8
Fan & Motor Speed, revs./min.	1140	1140	1140	1140	1140	1140	1140	1140
Fan Diameter, inches	35.4	35.4	35.4	35.4	35.4	35.4	35.4	35.4
Fan Tip Speed, ft./min.	10575	10575	10575	10575	10575	10575	10575	10575
Total Chiller Airflow, cfm	182000	208000	208000	234000	260000	286000	312000	312000
Ultra Quiet Fans								
Fan Motor, HP/kW	2/1.50	2/1.50	2/1.50	2/1.50	2/1.50	2/1.50	2/1.50	2/1.50
Fan & Motor Speed, revs./min.	838	838	838	838	838	838	838	838
Fan Diameter, inches	35.4	35.4	35.4	35.4	35.4	35.4	35.4	35.4
Fan Tip Speed, ft./min.	7774	7774	7774	7774	7774	7774	7774	7774
Total Chiller Airflow, cfm	182000	208000	208000	234000	260000	286000	312000	312000
Evaporator, Direct Expansion								
Water Volume, gals.	202.0	202.0	236.0	236.0	266.0	318.0	318.0	318.0
Maximum Water Side Pressure, PSIG	150	150	150	150	150	150	150	150
Maximum Refrigerant Side Pressure, PSIG	235	235	235	235	235	235	235	235
Minimum Chilled Water Flow Rate, gpm	250	250	300	300	350	400	400	400
Maximum Chilled Water Flow Rate, gpm	1200	1200	1200	1200	1250	1400	1400	1400
Water Connections, inches	10	10	10	10	10	10	10	10

Contact your nearest York Sales Office for weight data.

Physical Data (SI - Standard Efficiency)

Refrigerant R-134a	STANDARD EFFICIENCY						
	MODEL NUMBER (YCAV___ S/P)						
	YCAV0157	YCAV0177	YCAV0187	YCAV0207	YCAV0227	YCAV0247	YCAV0267
General Unit Data							
Number of Independent Refrigerant Circuits	2	2	2	2	2	2	2
Refrigerant Charge, R-134a, Ckt.-1/Ckt.-2, kg.	74/74	77/77	84/77	87/80	87/87	105/89	105/105
Oil Charge, Ckt.-1/Ckt.-2, liters	19/19	19/19	19/19	19/19	19/19	19/19	19/19
Compressors, Semihhermetic Screw Qty per Chiller	2	2	2	2	2	2	2
Condensers, High Efficiency Fin/Tube with Integral Subcooler							
Total Chiller Coil Face Area, m ²	21.8	21.8	24.5	24.5	27.2	30.0	32.7
Number of Rows	3	3	3	3	3	3	3
Fins per meter	669	669	669	669	669	669	669
Condenser Fans							
Number, Ckt.-1/Ckt.-2	4/4	4/4	5/4	5/4	5/5	6/5	6/6
Low Sound Fans							
Fan Motor, HP/kw	2/1.50	2/1.50	2/1.50	2/1.50	2/1.50	2/1.50	2/1.50
Fan & Motor Speed, revs./sec.	19.0	19.0	19.0	19.0	19.0	19.0	19.0
Fan Diameter, mm	899	899	899	899	899	899	899
Fan Tip Speed, m/sec.	53.7	53.7	53.7	53.7	53.7	53.7	53.7
Total Chiller Airflow, l/sec.	49082	49082	55218	55218	61353	67488	73624
Ultra Quiet Fans							
Fan Motor, HP/kw	2/1.50	2/1.50	2/1.50	2/1.50	2/1.50	2/1.50	2/1.50
Fan & Motor Speed, revs./sec.	14.0	14.0	14.0	14.0	14.0	14.0	14.0
Fan Diameter, mm	899	899	899	899	899	899	899
Fan Tip Speed, m/sec.	39	39	39	39	39	39	39
Total Chiller Airflow, l/sec.	49082	49082	55218	55218	61353	67488	73624
Evaporator, Direct Expansion							
Water Volume, liters	253.6	359.6	359.6	529.9	529.9	529.9	529.9
Maximum Water Side Pressure, Bar ¹	10	10	10	10	10	10	10
Maximum Refrigerant Side Pressure, Bar	16	16	16	16	16	16	16
Minimum Chilled Water Flow Rate, l/sec.	8.8	10.1	10.1	11.4	11.4	11.4	11.4
Maximum Chilled Water Flow Rate, l/sec.	42.6	47.3	47.3	50.5	50.5	50.5	50.5
Water Connections, inches	8	10	10	10	10	10	10

Contact your nearest York Sales Office for weight data.

¹ Optional 21 Bar Waterside available

Physical Data (SI - High Efficiency)

FORM 201.21-EG1 (607)

Refrigerant R-134a	HIGH EFFICIENCY						
	MODEL NUMBER (YCAV___ E/V)						
	YCAV0157	YCAV0177	YCAV0187	YCAV0197	YCAV0207	YCAV0227	YCAV0247
General Unit Data							
Number of Independent Refrigerant Circuits	2	2	2	2	2	2	2
Refrigerant Charge, R-134a, Ckt.-1/Ckt.-2, kg.	77/77	84/77	84/84	87/87	102/87	102/102	105/105
Oil Charge, Ckt.-1/Ckt.-2, liters	19/19	19/19	19/19	19/19	19/19	19/19	19/19
Compressors, Semihermetic Screw Qty per Chiller	2	2	2	2	2	2	2
Condensers, High Efficiency Fin/Tube with Integral Subcooler							
Total Chiller Coil Face Area, m ²	21.8	24.5	27.2	27.2	30.0	32.7	32.7
Number of Rows	3	3	3	3	3	3	3
Fins per meter	669	669	669	669	669	669	669
Condenser Fans							
Number, Ckt.-1/Ckt.-2	4/4	5/4	5/5	5/5	6/5	6/6	6/6
Standard Fans							
Fan Motor, HP/kw	2/1.50	2/1.50	2/1.50	2/1.50	2/1.50	2/1.50	2/1.50
Fan & Motor Speed, revs./sec.	19.0	19.0	19.0	19.0	19.0	19.0	19.0
Fan Diameter, mm	899	899	899	899	899	899	899
Fan Tip Speed, m/sec.	53.7	53.7	53.7	53.7	53.7	53.7	53.7
Total Chiller Airflow, l/sec.	49082	55218	61353	61353	67488	73624	73624
Low Noise Fans							
Fan Motor, HP/kw	2/1.50	2/1.50	2/1.50	2/1.50	2/1.50	2/1.50	2/1.50
Fan & Motor Speed, revs./sec.	14.0	14.0	14.0	14.0	14.0	14.0	14.0
Fan Diameter, mm	899	899	899	899	899	899	899
Fan Tip Speed, m/sec.	39	39	39	39	39	39	39
Total Chiller Airflow, l/sec.	49082	55218	61353	61353	67488	73624	73624
Evaporator, Direct Expansion							
Water Volume, liters	359.6	359.6	359.6	416.4	416.4	416.4	529.9
Maximum Water Side Pressure, Bar ¹	10	10	10	10	10	10	10
Maximum Refrigerant Side Pressure, Bar	16	16	16	16	16	16	16
Minimum Chilled Water Flow Rate, l/sec.	10.1	10.1	10.1	11.4	11.4	11.4	11.4
Maximum Chilled Water Flow Rate, l/sec.	47.3	47.3	47.3	47.3	47.3	47.3	50.5
Water Connections, inches	10	10	10	10	10	10	10

Contact your nearest York Sales Office for weight data.

¹ Optional 21 Bar Waterside available

Physical Data (SI - Standard Efficiency)

Refrigerant R-134a	STANDARD EFFICIENCY								
	MODEL NUMBER (YCAV ___ S/P)								
	60Hz	YCAV0287	YCAV0307	YCAV0357	YCAV0397	YCAV0417	YCAV0457	YCAV0477	YCAV0507
50Hz	-	-	-	-	YCAV1549	YCAV1649	YCAV1739	YCAV1829	YCAV1909
General Unit Data									
Number of Independent Refrigerant Circuits	3	3	3	3	4	4	4	4	4
Refrigerant Charge, R-134a, Ckt.-1/Ckt.-2, kg.	84 / 77 / 77	84 / 84 / 77	84 / 84 / 105	105 / 105 / 105	84 / 84 / 84 / 84	105 / 84 / 84 / 84	105 / 105 / 84 / 84	105 / 105 / 84 / 84	105 / 105 / 105 / 105
Oil Charge, Ckt.-1/Ckt.-2, liters	19 / 15 / 15	19 / 19 / 15	19 / 19 / 19	19 / 19 / 19	19 / 19 / 19 / 19	19 / 19 / 19 / 19	19 / 19 / 19 / 19	19 / 19 / 19 / 19	19 / 19 / 19 / 19
Glycol Charge (43% concentration), liters	0	0	0	0	0	0	0	0	0
Compressors, Semihermetic Screw									
Quantity per Chiller	3	3	3	3	4	4	4	4	4
Condensers, High Efficiency Fin/Tube with Integral Subcooler									
Total Chiller Coil Face Area, m ²	35	38	44	49	55	57	60	60	65
Number of Rows	3	3	3	3	3	3	3	3	3
Fins per meter	669	669	669	669	669	669	669	669	669
Condenser Fans									
Number, Ckt.-1/Ckt.-2	5/4/4	5/5/4	5/5/6	6/6/6	5 / 5 / 5 / 5	6 / 5 / 5 / 5	6 / 6 / 5 / 5	6 / 6 / 5 / 6	6 / 6 / 6 / 6
Standard Fans									
Fan Motor, HP/kW	2/1.50	2/1.50	2/1.50	2/1.50	2/1.50	2/1.50	2/1.50	2/1.50	2/1.50
Fan & Motor Speed, revs./sec.	19	19	19	19	19	19	19	19	19
Fan Diameter, mm	899.2	899.2	899.2	899.2	899.2	899.2	899.2	899.2	899.2
Fan Tip Speed, m/sec.	54	54	54	54	54	54	54	54	54
Total Chiller Airflow, l/sec.	79768	85904	98176	110448	122720	128856	134992	134992	147264
Low Noise Fans									
Fan Motor, HP/kW	2/1.50	2/1.50	2/1.50	2/1.50	2/1.50	2/1.50	2/1.50	2/1.50	2/1.50
Fan & Motor Speed, revs./sec.	14	14	14	14	14	14	14	14	14
Fan Diameter, mm	899.2	899.2	899.2	899.2	899.2	899.2	899.2	899.2	899.2
Fan Tip Speed, m/sec.	39	39	39	39	39	39	39	39	39
Total Chiller Airflow, l/sec.	79768	85904	98176	110448	122720	128856	134992	134992	147264
Evaporator, Direct Expansion									
Water Volume, liters	764.6	893.3	893.3	893.3	1006.8	1006.8	1203.6	1203.6	1203.6
Maximum Water Side Pressure, Bar	10	10	10	10	10	10	10	10	10
Maximum Refrigerant Side Pressure, Bar	16	16	16	16	16	16	16	16	16
Minimum Chilled Water Flow Rate, l/sec.	16	19	19	19	22	22	25	25	25
Maximum Chilled Water Flow Rate, l/sec.	76	76	76	76	79	79	88	88	88
Water Connections, mm	245	245	245	245	245	245	245	245	245

Physical Data (SI - High Efficiency)

FORM 201.21-EG1 (607)

Refrigerant R-134a	HIGH EFFICIENCY							
	MODEL NUMBER (YCAV ___ E/V)							
	60Hz	YCAV0267	YCAV0287	YCAV0327	YCAV0357	YCAV0397	YCAV0417	YCAV0477
50Hz	-	-	-	-	-	YCAV1429	YCAV1549	YCAV1739
General Unit Data								
Number of Independent Refrigerant Circuits	3	3	3	3	4	4	4	4
Refrigerant Charge, R-134a, Ckt.-1/Ckt.-2, kg.	84 / 84 / 77	84 / 84 / 105	84 / 84 / 105	105 / 105 / 105	84 / 84 / 84 / 84	105 / 105 / 84 / 84	105 / 105 / 105 / 105	105 / 105 / 105 / 105
Oil Charge, Ckt.-1/Ckt.-2, liters	19 / 19 / 15	19 / 19 / 19	19 / 19 / 19	19 / 19 / 19	19 / 19 / 19 / 19	19 / 19 / 19 / 19	19 / 19 / 19 / 19	19 / 19 / 19 / 19
Glycol Charge (43% concentration), liters	0	0	0	0	0	0	0	0
Compressors, Semihermetic Screw								
Quantity per Chiller	3	3	3	3	4	4	4	4
Condensers, High Efficiency Fin/Tube with Integral Subcooler								
Total Chiller Coil Face Area, m ²	38	44	44	49	53	60	65	65
Number of Rows	3	3	3	3	3	3	3	3
Fins per meter	669	669	669	669	669	669	669	669
Condenser Fans								
Number, Ckt.-1/Ckt.-2	05/05/04	05/05/06	05/05/06	06/06/06	5 / 5 / 5 / 5	6 / 6 / 5 / 5	6 / 6 / 6 / 6	6 / 6 / 6 / 6
Standard Fans								
Fan Motor, HP/kW	2/1.50	2/1.50	2/1.50	2/1.50	2/1.50	2/1.50	2/1.50	2/1.50
Fan & Motor Speed, revs./sec.	19	19	19	19	19	19	19	19
Fan Diameter, mm	899.2	899.2	899.2	899.2	899.2	899.2	899.2	899.2
Fan Tip Speed, m/sec.	54	54	54	54	54	54	54	54
Total Chiller Airflow, l/sec.	85904	98176	98176	110448	122720	134992	147264	147264
Low Noise Fans								
Fan Motor, HP/kW	2/1.50	2/1.50	2/1.50	2/1.50	2/1.50	2/1.50	2/1.50	2/1.50
Fan & Motor Speed, revs./sec.	14	14	14	14	14	14	14	14
Fan Diameter, mm	899.2	899.2	899.2	899.2	899.2	899.2	899.2	899.2
Fan Tip Speed, m/sec.	39	39	39	39	39	39	39	39
Total Chiller Airflow, l/sec.	85904	98176	98176	110448	122720	134992	147264	147264
Evaporator, Direct Expansion								
Water Volume, liters	764.6	764.6	893.3	893.3	1006.8	1203.6	1203.6	1203.6
Maximum Water Side Pressure, Bar	10	10	10	10	10	10	10	10
Maximum Refrigerant Side Pressure, Bar	16	16	16	16	16	16	16	16
Minimum Chilled Water Flow Rate, l/sec.	16	16	19	19	22	25	25	25
Maximum Chilled Water Flow Rate, l/sec.	76	76	76	76	79	88	88	88
Water Connections, mm	245	245	245	245	245	245	245	245

Dimensions – English

YCAV0157S/P

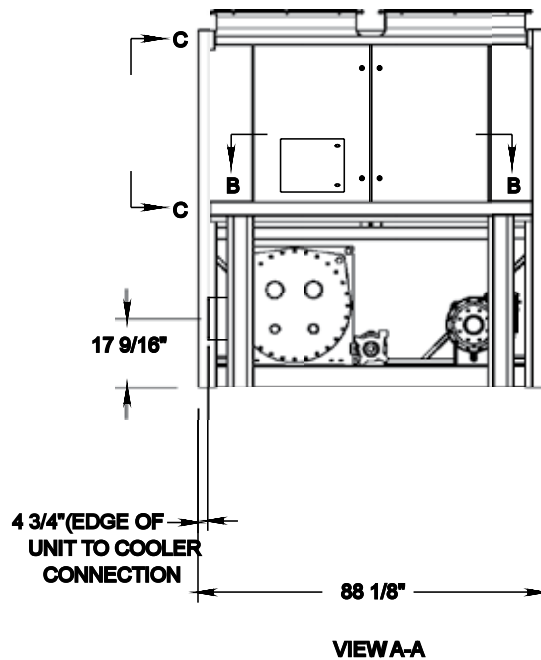
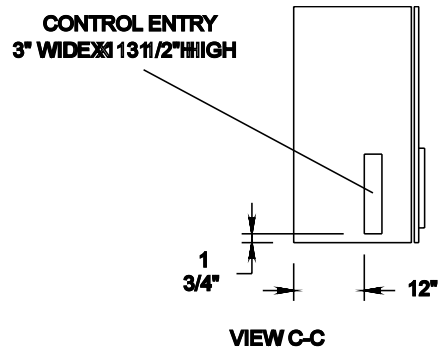
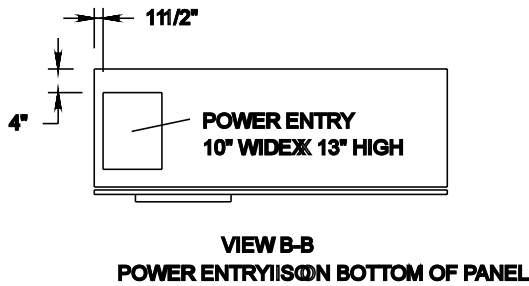

Notes:

1. Placement on a level surface free of obstructions (including snow, for winter operation) or air recirculation ensures rated performance, reliable operation and ease of maintenance. Site restrictions may compromise minimum clearances indicated below, resulting in unpredictable air patterns and possible diminished performance. York's unit controls will optimize operation without nuisance high pressure safety cutout; however, the system designer must consider potential performance degradation. Access to the unit control center assumes the unit is no higher than on spring isolators. Recommended minimum clearances: side to wall - 6'; rear to wall - 6'; control panel end to wall - 4'; top - no obstructions allowed; distance between adjacent units - 10'. No more than one adjacent wall may be higher than the unit.

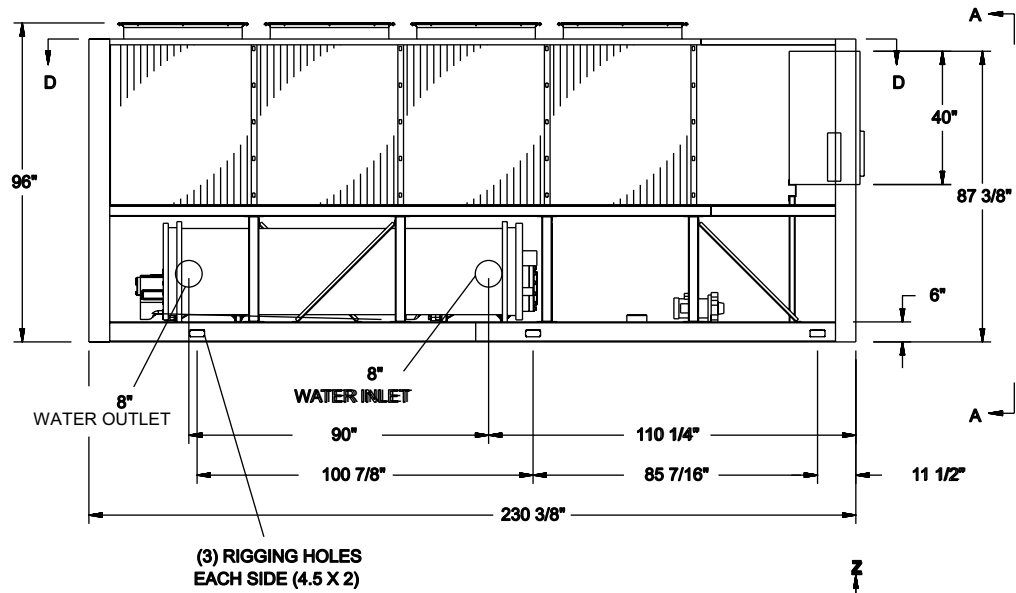
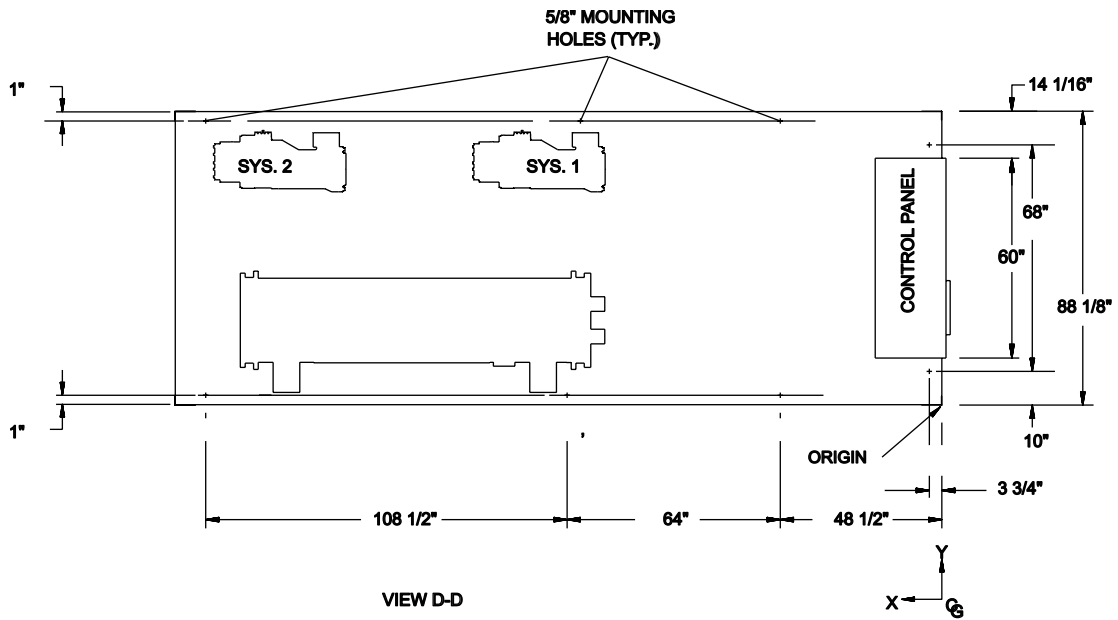

POWER: SINGLE POINT WITH TERMINAL BLOCK

Dimensions – English

YCAV0157E/V, 0177S/P

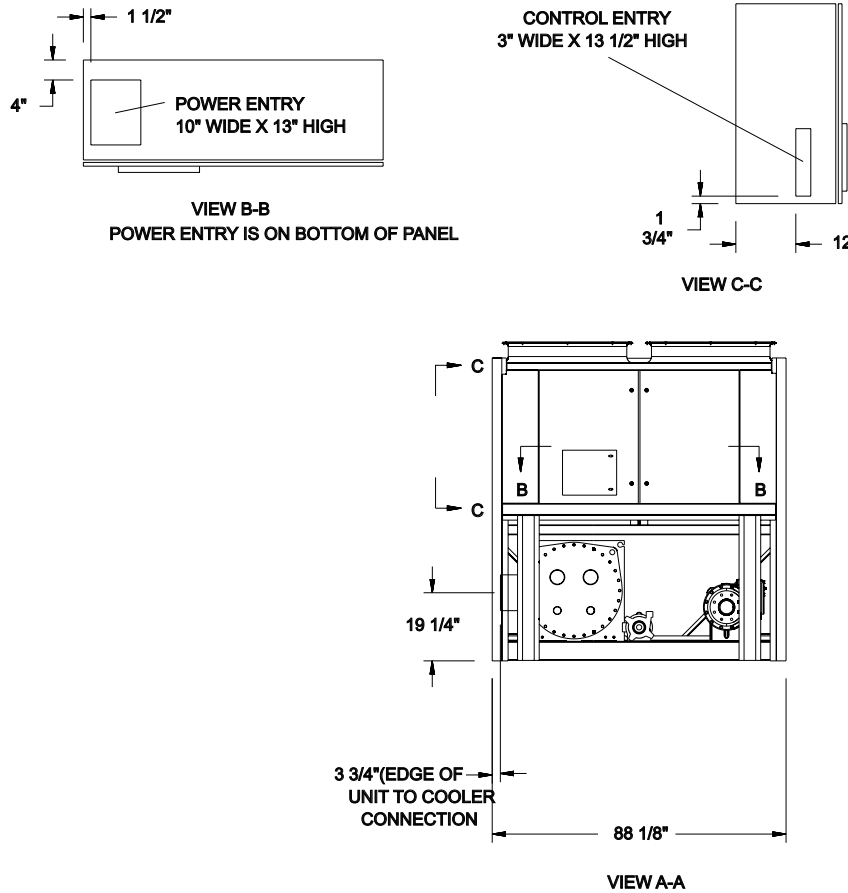

NOTES:

1. Placement on a level surface free of obstructions (including snow, for winter operation) or air recirculation ensures rated performance, reliable operation and ease of maintenance. Site restrictions may compromise minimum clearances indicated below, resulting in unpredictable air patterns and possible diminished performance. York's unit controls will optimize operation without nuisance high pressure safety cutout; however, the system designer must consider potential performance degradation. Access to the unit control center assumes the unit is no higher than on spring isolators. Recommended minimum clearances: side to wall - 6'; rear to wall - 6'; control panel end to wall - 4'; top - no obstructions allowed; distance between adjacent units - 10'. No more than one adjacent wall may be higher than the unit.

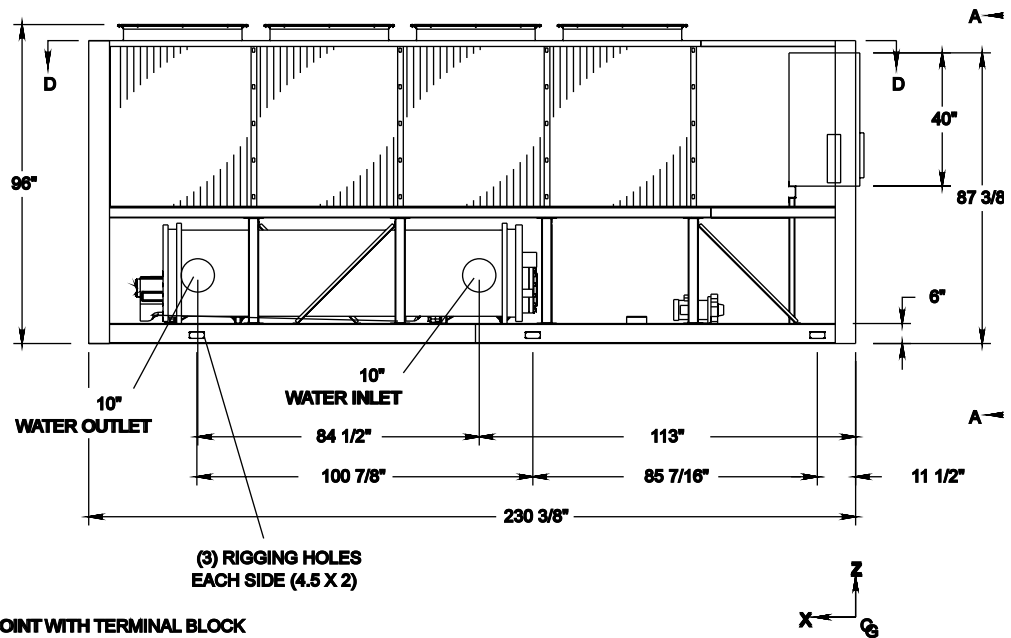
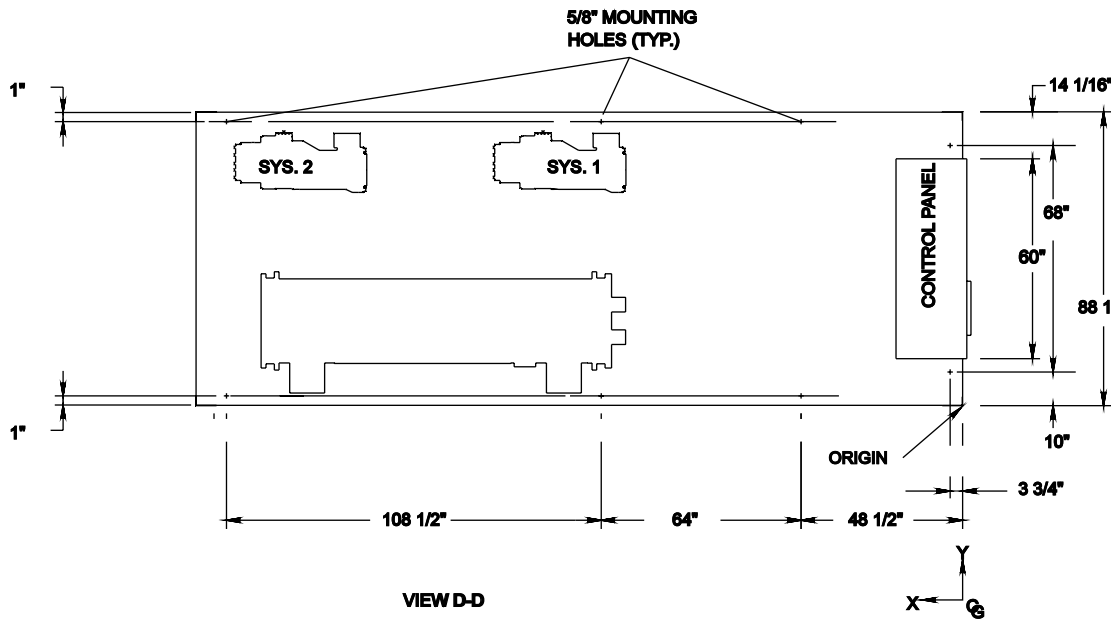

Dimensions – English

YCAV0177E/V, 0187S/P, 0187E/V

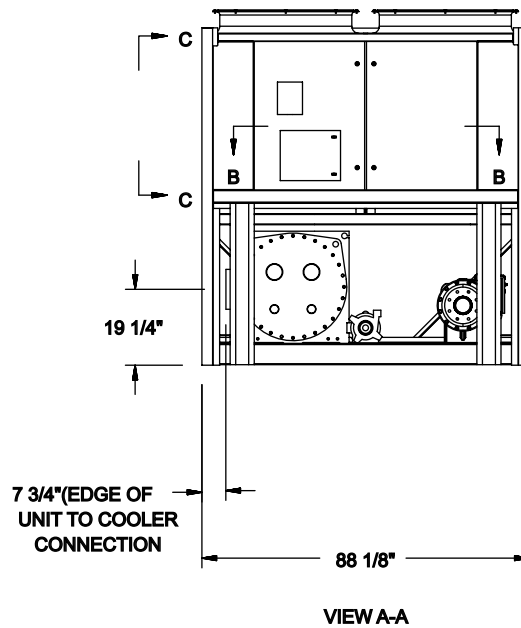
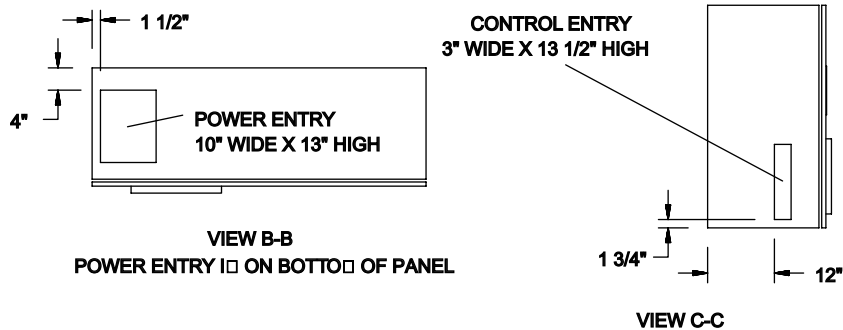

Notes:

1. Placement on a level surface free of obstructions (including snow, for winter operation) or air recirculation ensures rated performance, reliable operation and ease of maintenance. Site restrictions may compromise minimum clearances indicated below, resulting in unpredictable air patterns and possible diminished performance. York's unit controls will optimize operation without nuisance high pressure safety cutout; however, the system designer must consider potential performance degradation. Access to the unit control center assumes the unit is no higher than on spring isolators. Recommended minimum clearances: side to wall - 6'; rear to wall - 6'; control panel end to wall - 4'; top - no obstructions allowed; distance between adjacent units - 10'. No more than one adjacent wall may be higher than the unit.

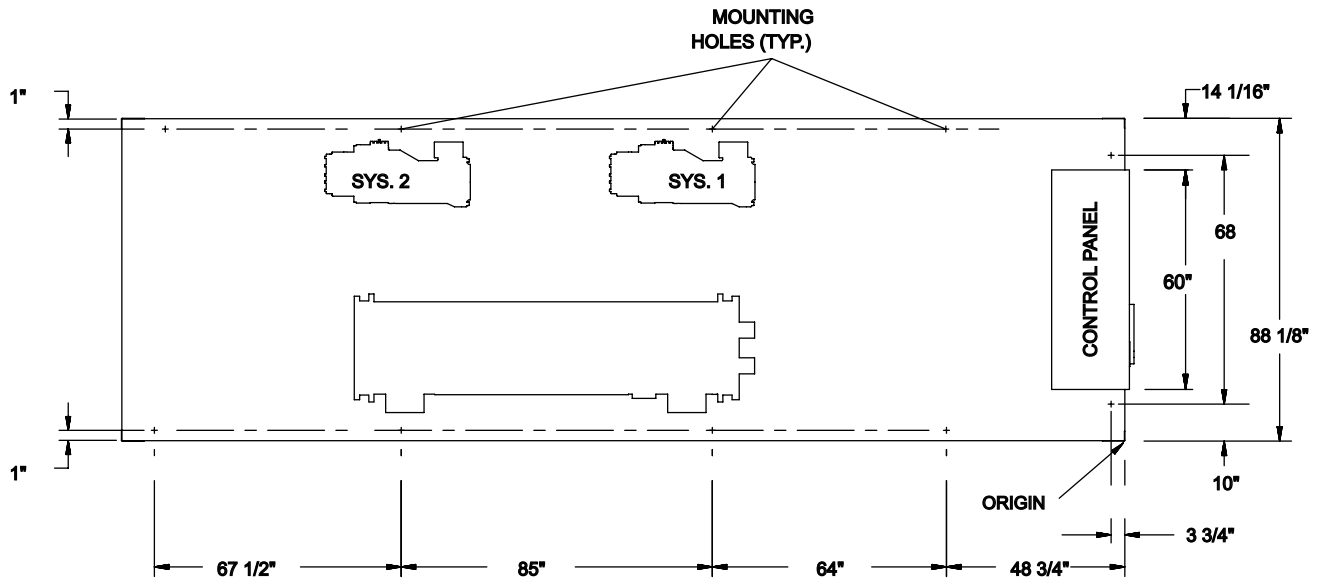

VIEW D-D

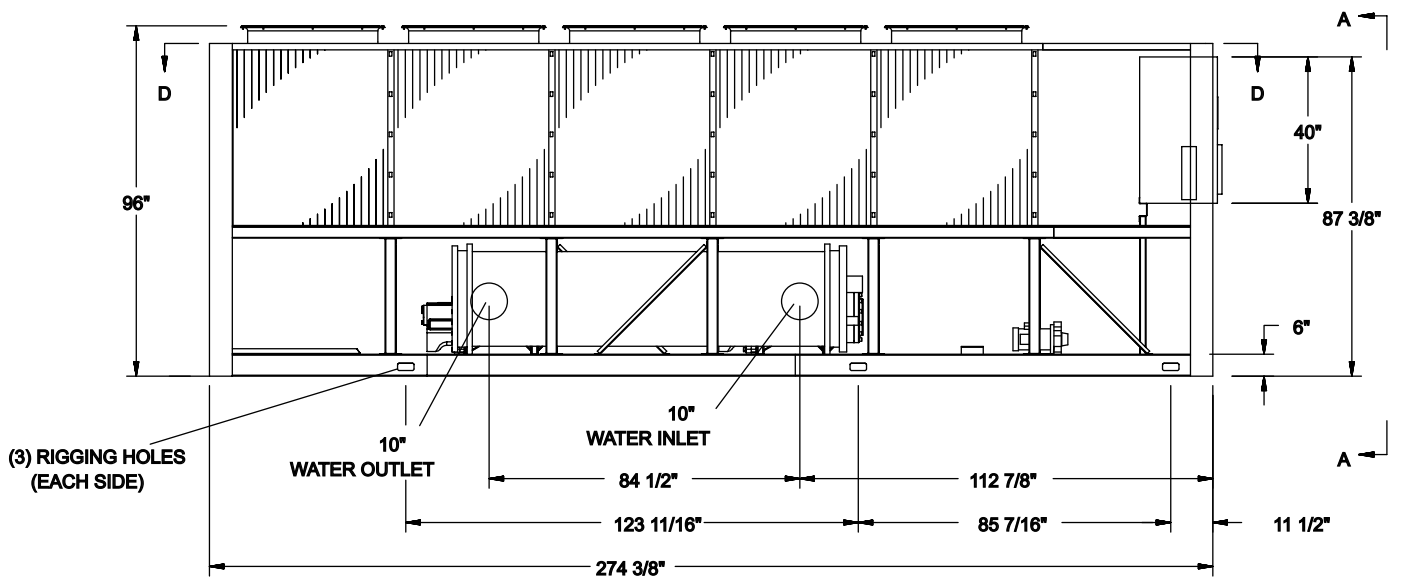

Dimensions – English

YCAV0197E/V

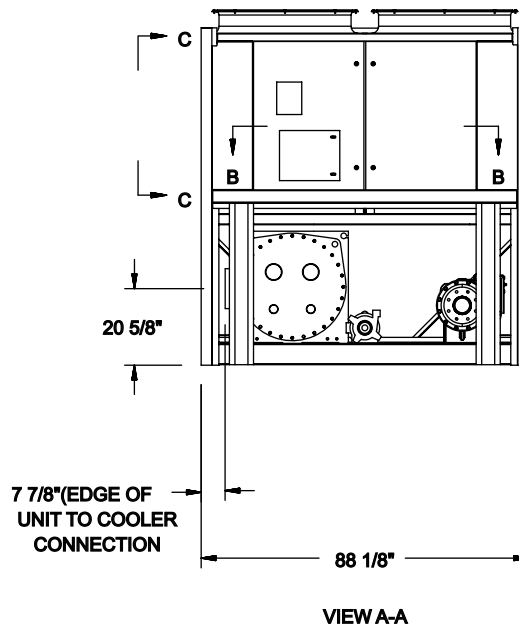
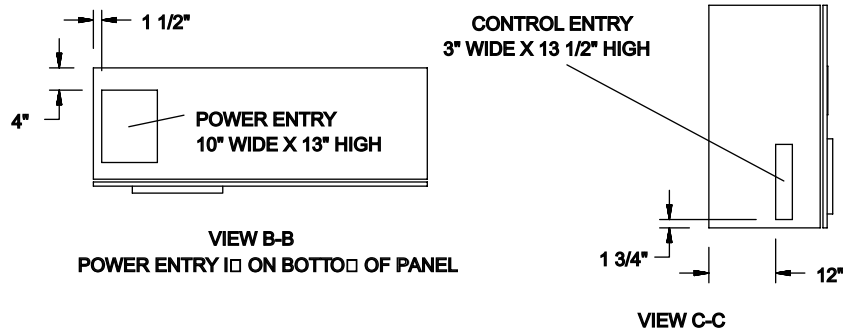

Notes:

1. Placement on a level surface free of obstructions (including snow, for winter operation) or air recirculation ensures rated performance, reliable operation and ease of maintenance. Site restrictions may compromise minimum clearances indicated below, resulting in unpredictable air patterns and possible diminished performance. York's unit controls will optimize operation without nuisance high pressure safety cutout; however, the system designer must consider potential performance degradation. Access to the unit control center assumes the unit is no higher than on spring isolators. Recommended minimum clearances: side to wall - 6'; rear to wall - 6'; control panel end to wall - 4'; top - no obstructions allowed; distance between adjacent units - 10'. No more than one adjacent wall may be higher than the unit.

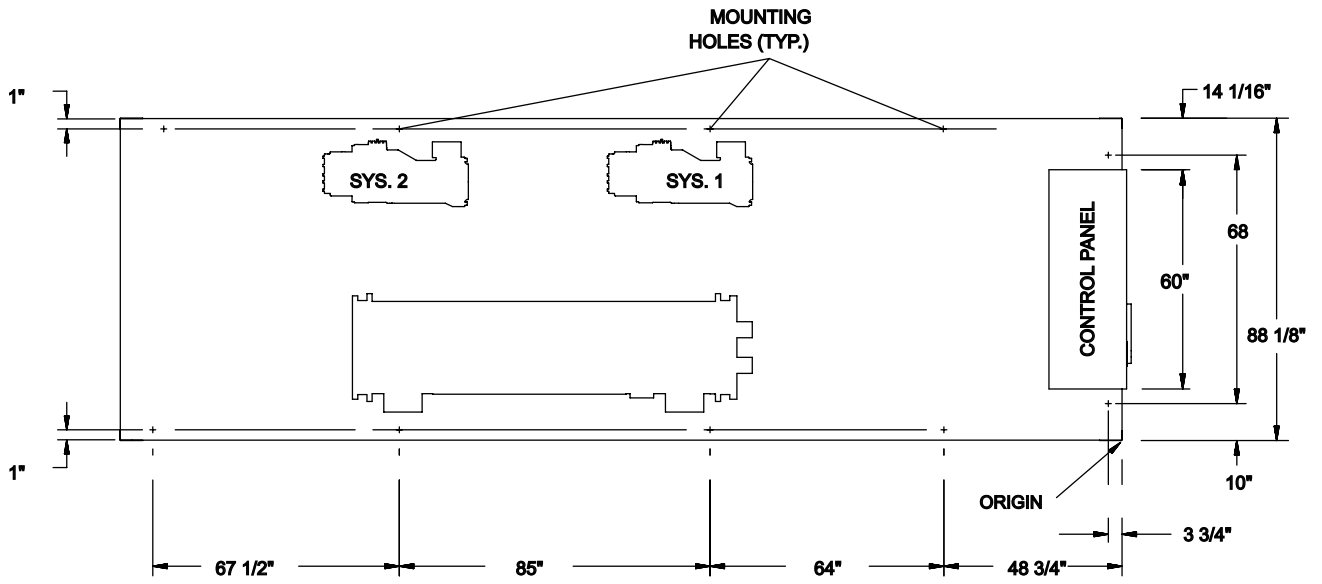

VIEW D-D

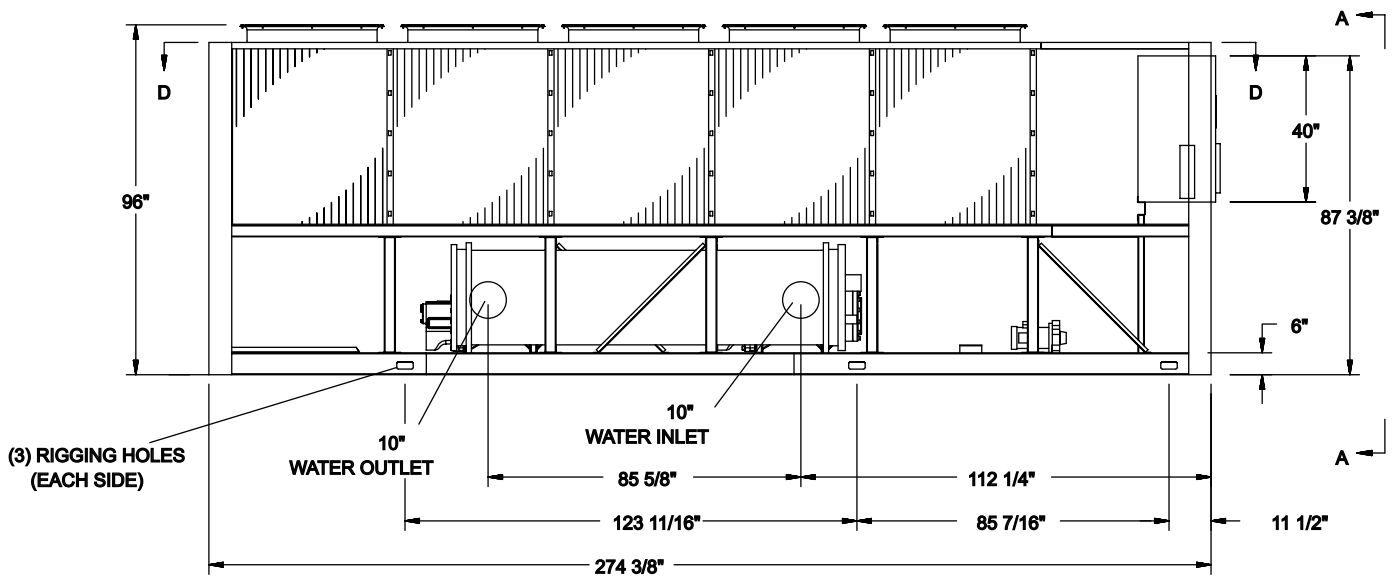

Dimensions – English

YCAV0207S/P, 0227S/P

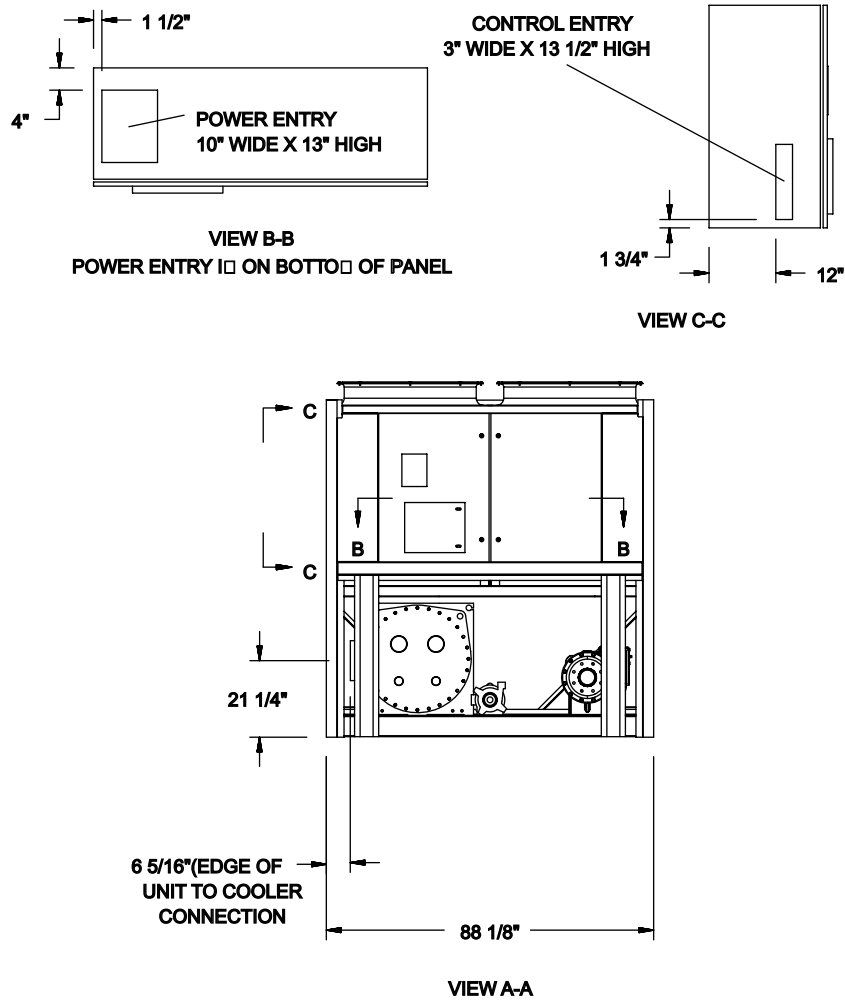

Notes:

1. Placement on a level surface free of obstructions (including snow, for winter operation) or air recirculation ensures rated performance, reliable operation and ease of maintenance. Site restrictions may compromise minimum clearances indicated below, resulting in unpredictable air patterns and possible diminished performance. York's unit controls will optimize operation without nuisance high pressure safety cutout; however, the system designer must consider potential performance degradation. Access to the unit control center assumes the unit is no higher than on spring isolators. Recommended minimum clearances: side to wall - 6'; rear to wall - 6'; control panel end to wall - 4'; top - no obstructions allowed; distance between adjacent units - 10'. No more than one adjacent wall may be higher than the unit.

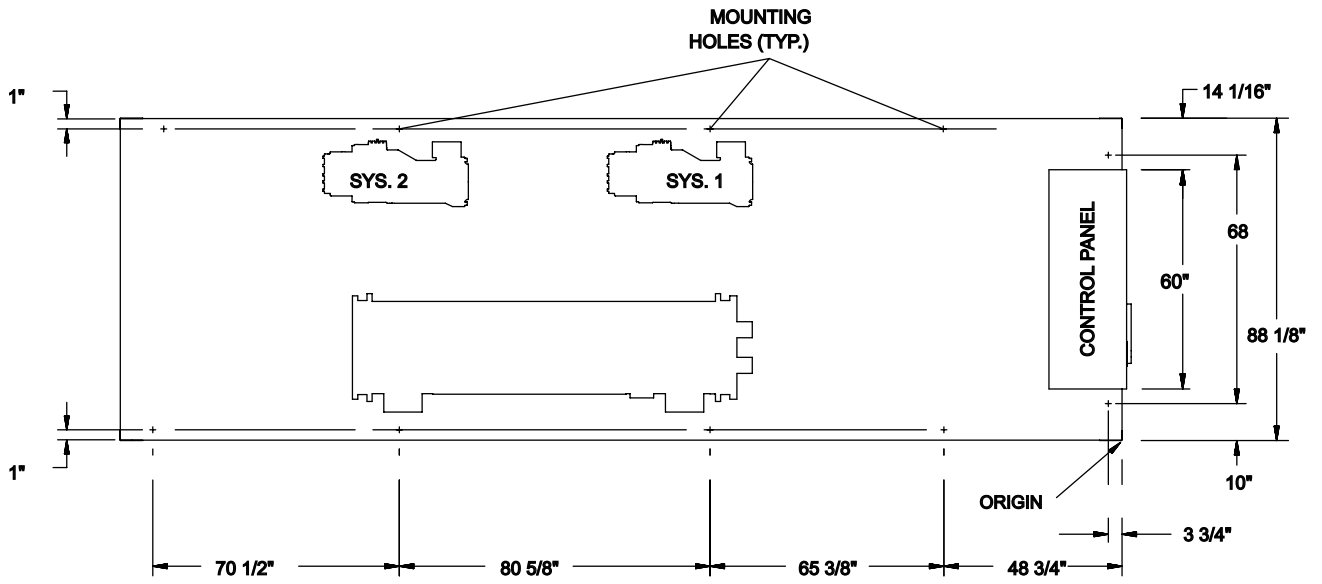

VIEW D-D

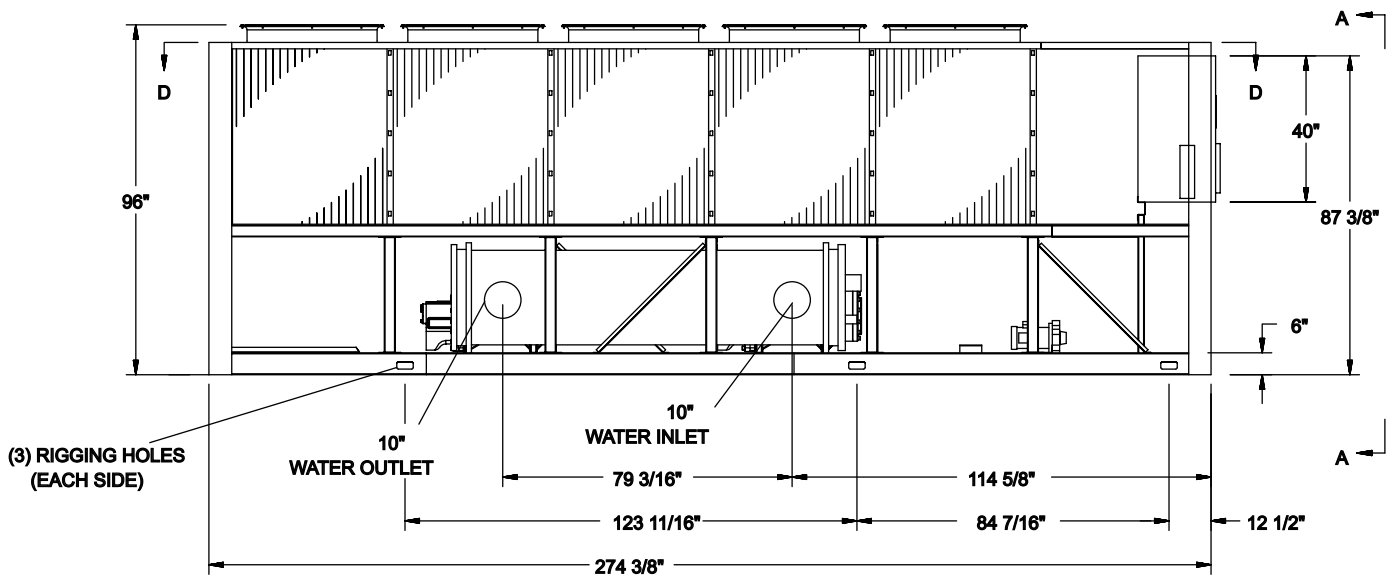

Dimensions – English

YCAV0207E/V, 0227E/V

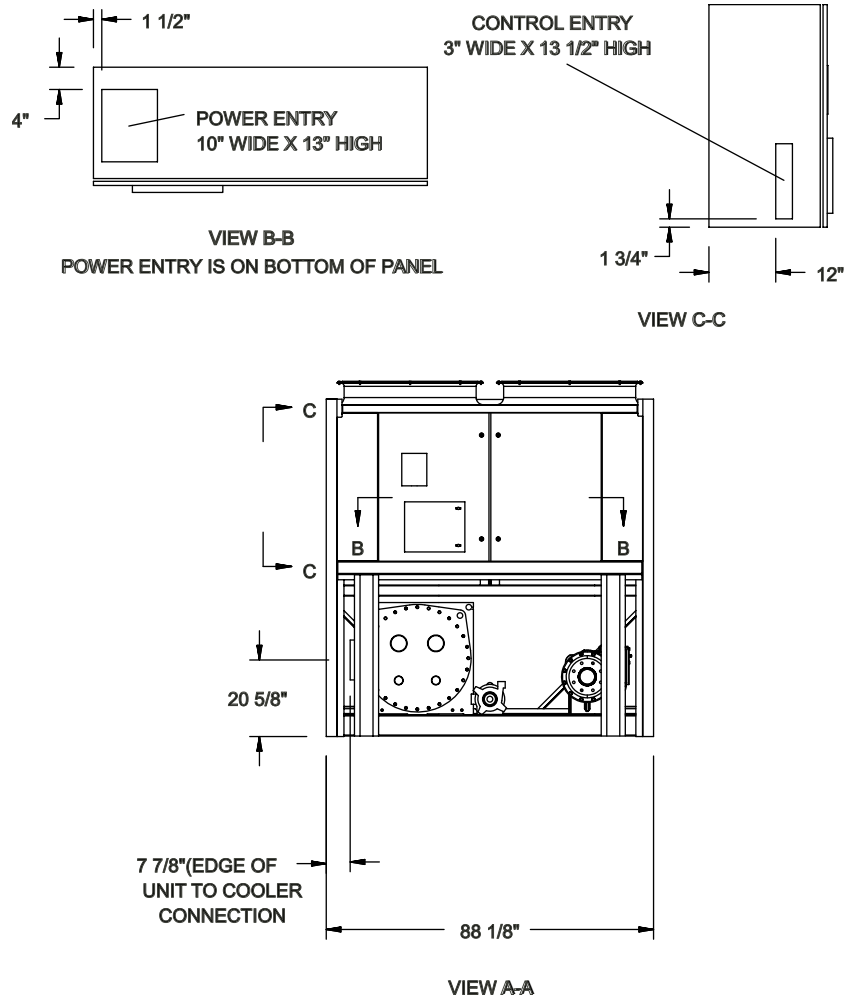

Notes:

1. Placement on a level surface free of obstructions (including snow, for winter operation) or air recirculation ensures rated performance, reliable operation and ease of maintenance. Site restrictions may compromise minimum clearances indicated below, resulting in unpredictable air patterns and possible diminished performance. York's unit controls will optimize operation without nuisance high pressure safety cutout; however, the system designer must consider potential performance degradation. Access to the unit control center assumes the unit is no higher than on spring isolators. Recommended minimum clearances: side to wall - 6'; rear to wall - 6'; control panel end to wall - 4'; top - no obstructions allowed; distance between adjacent units - 10'. No more than one adjacent wall may be higher than the unit.

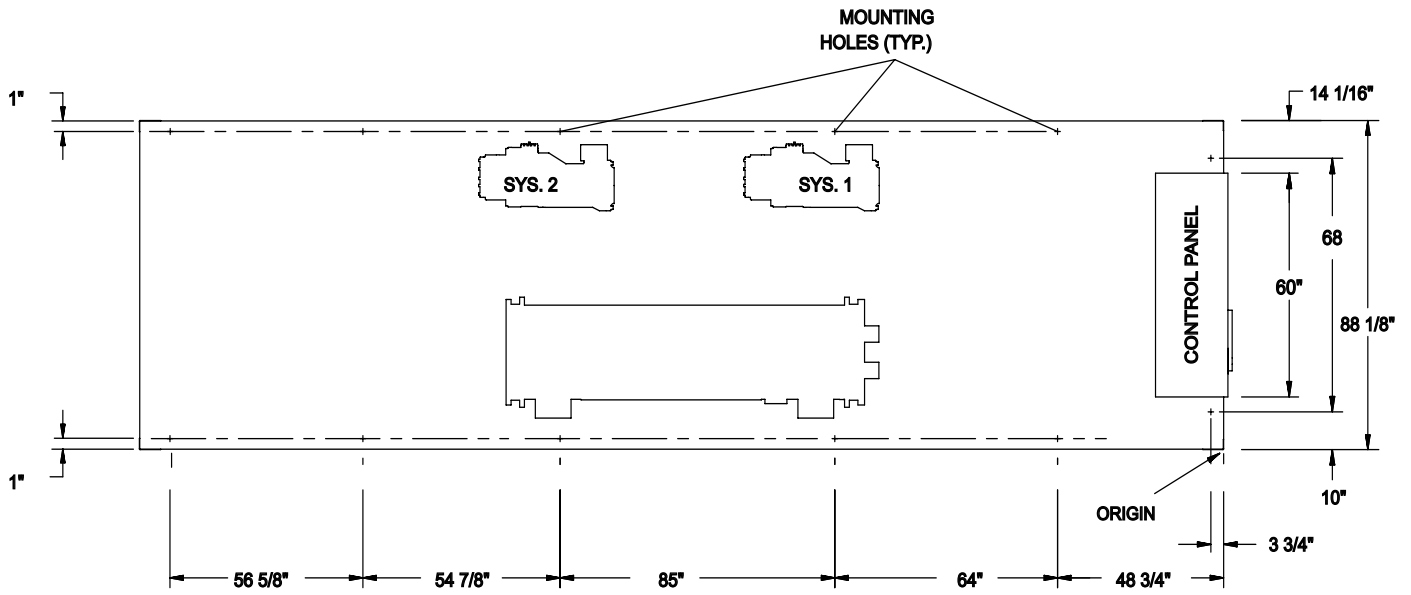

VIEW D-D

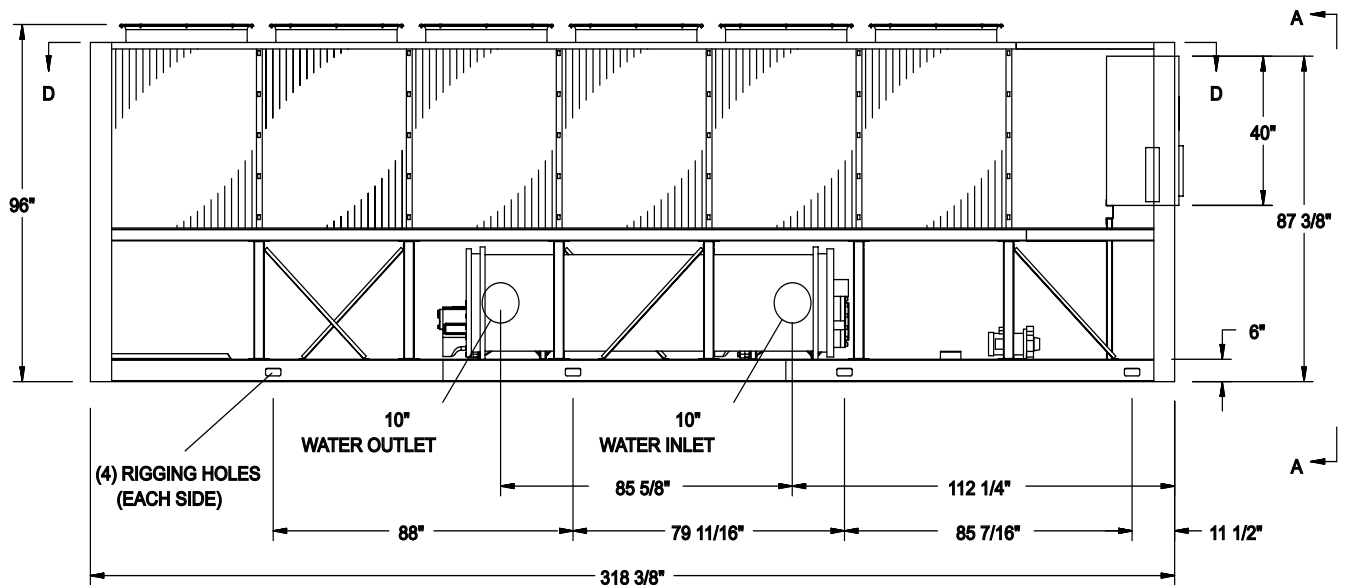

Dimensions – English

YCAV0247S/P, 0247E/V,

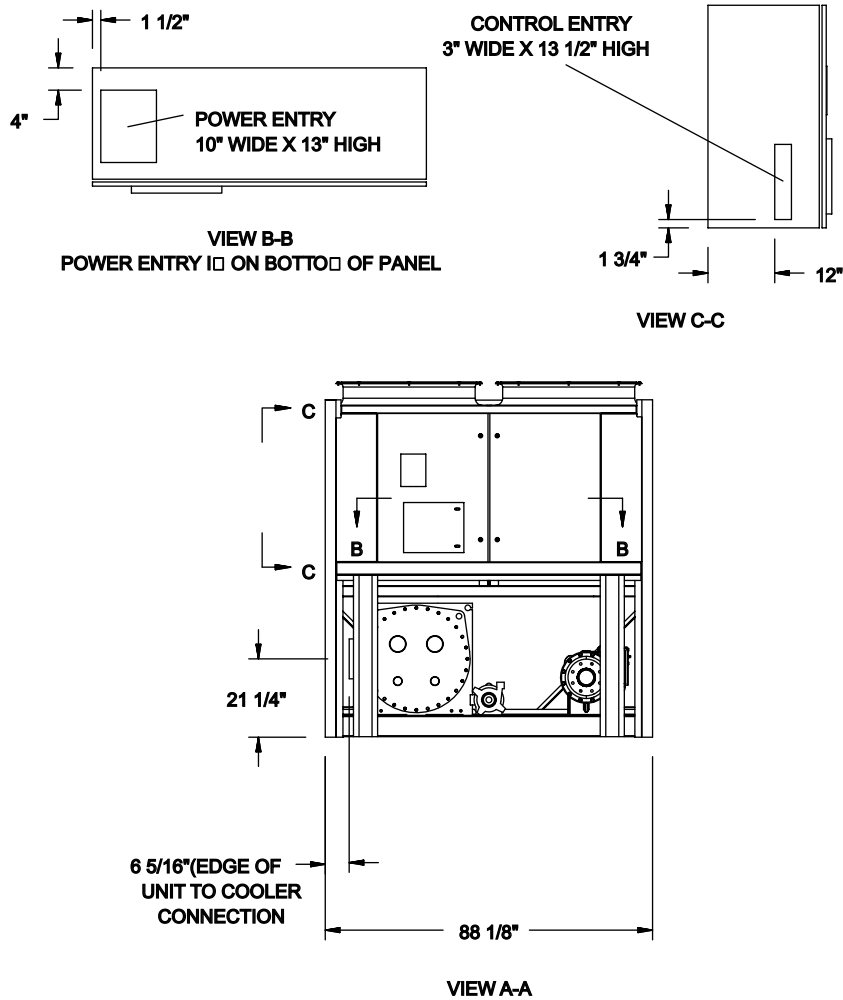

Notes:

1. Placement on a level surface free of obstructions (including snow, for winter operation) or air recirculation ensures rated performance, reliable operation and ease of maintenance. Site restrictions may compromise minimum clearances indicated below, resulting in unpredictable air patterns and possible diminished performance. York's unit controls will optimize operation without nuisance high pressure safety cutout; however, the system designer must consider potential performance degradation. Access to the unit control center assumes the unit is no higher than on spring isolators. Recommended minimum clearances: side to wall - 6'; rear to wall - 6'; control panel end to wall - 4'; top - no obstructions allowed; distance between adjacent units - 10'. No more than one adjacent wall may be higher than the unit.

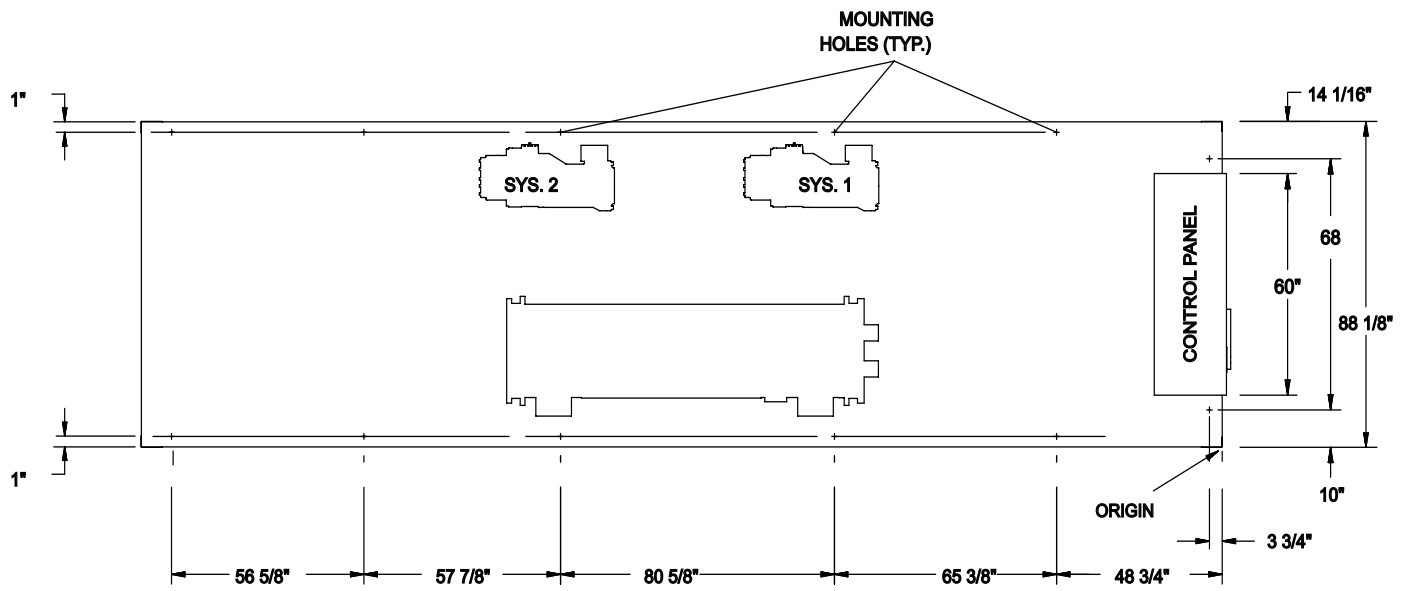

VIEW D-D

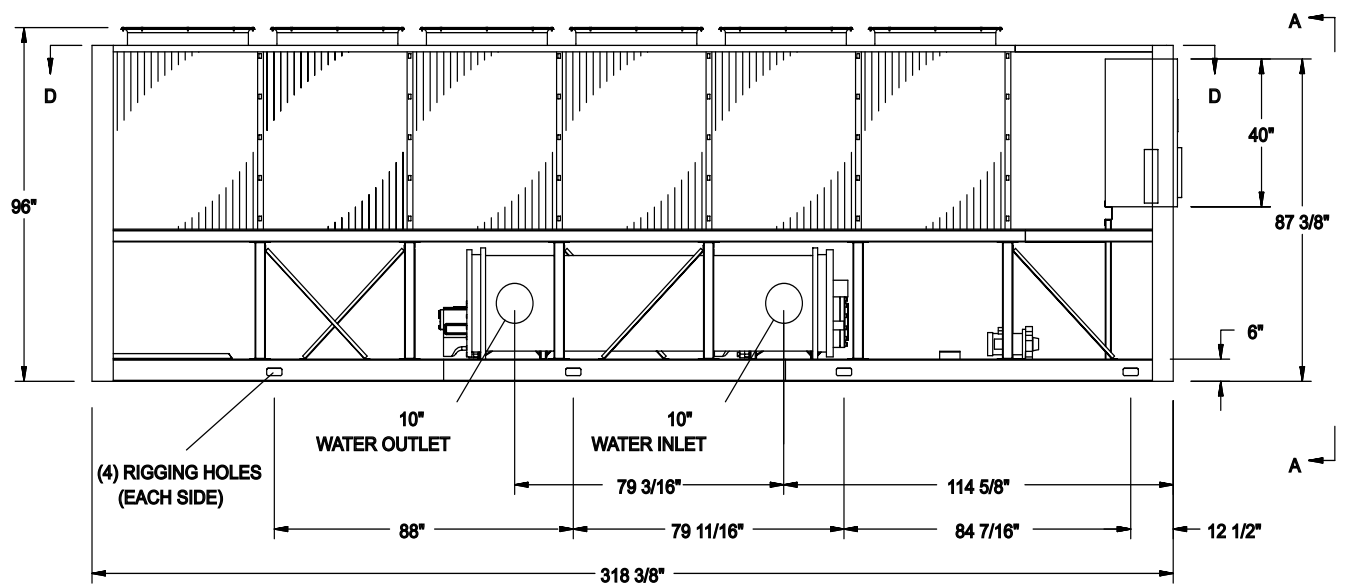

Dimensions – English

YCAV0267E/V, 0287S/P

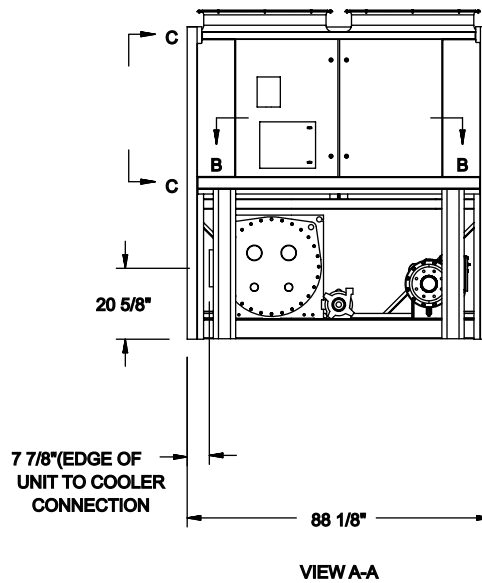
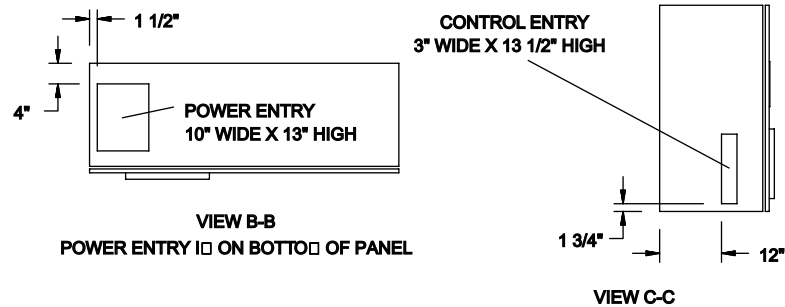

Notes:
 1. Placement on a level surface free of obstructions (including snow, for winter operation) or air recirculation ensures rated performance, reliable operation and ease of maintenance. Site restrictions may compromise minimum clearances indicated below, resulting in unpredictable air patterns and possible diminished performance. York's unit controls will optimize operation without nuisance high pressure safety cutout; however, the system designer must consider potential performance degradation. Access to the unit control center assumes the unit is no higher than on spring isolators. Recommended minimum clearances: side to wall - 6'; rear to wall - 6'; control panel end to wall - 4'; top - no obstructions allowed; distance between adjacent units - 10'. No more than one adjacent wall may be higher than the unit.

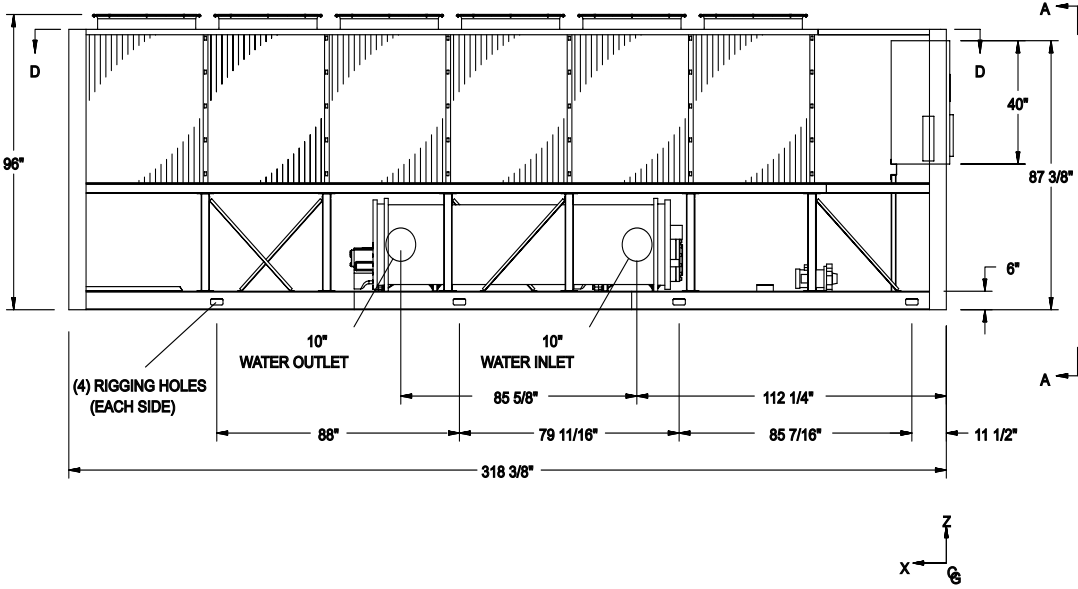
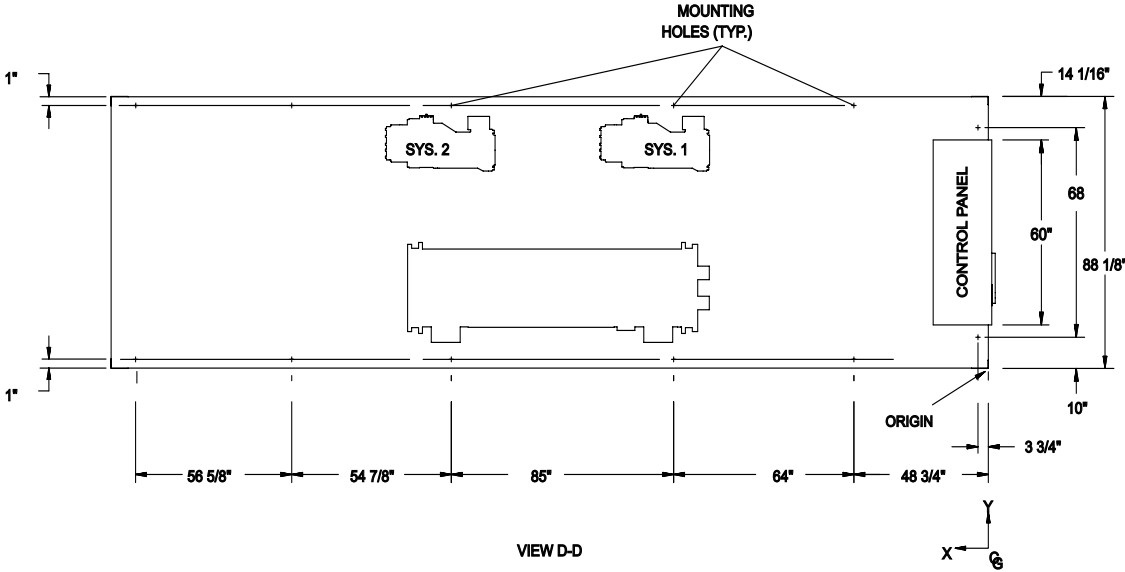

Dimensions – English

YCAV0287E/V

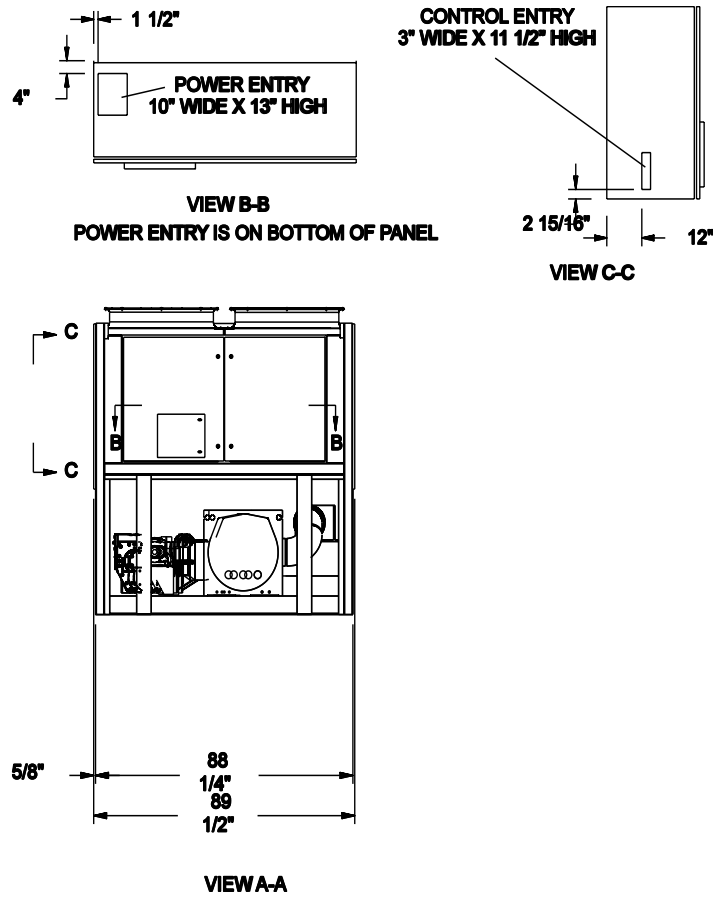

POWER: SINGLE POINT WITH TERMINAL BLOCK

Notes:
1. Placement on a level surface free of obstructions (including snow, for winter operation) or air recirculation ensures rated performance, reliable operation and ease of maintenance. Site restrictions may compromise minimum clearances indicated below, resulting in unpredictable air patterns and possible diminished performance. York's unit controls will optimize operation without nuisance high pressure safety cutout; however, the system designer must consider potential performance degradation. Access to the unit control center assumes the unit is no higher than on spring isolators. Recommended minimum clearances: side to wall - 6'; rear to wall - 6'; control panel end to wall - 4'; top - no obstructions allowed; distance between adjacent units - 10'. No more than one adjacent wall may be higher than the unit.

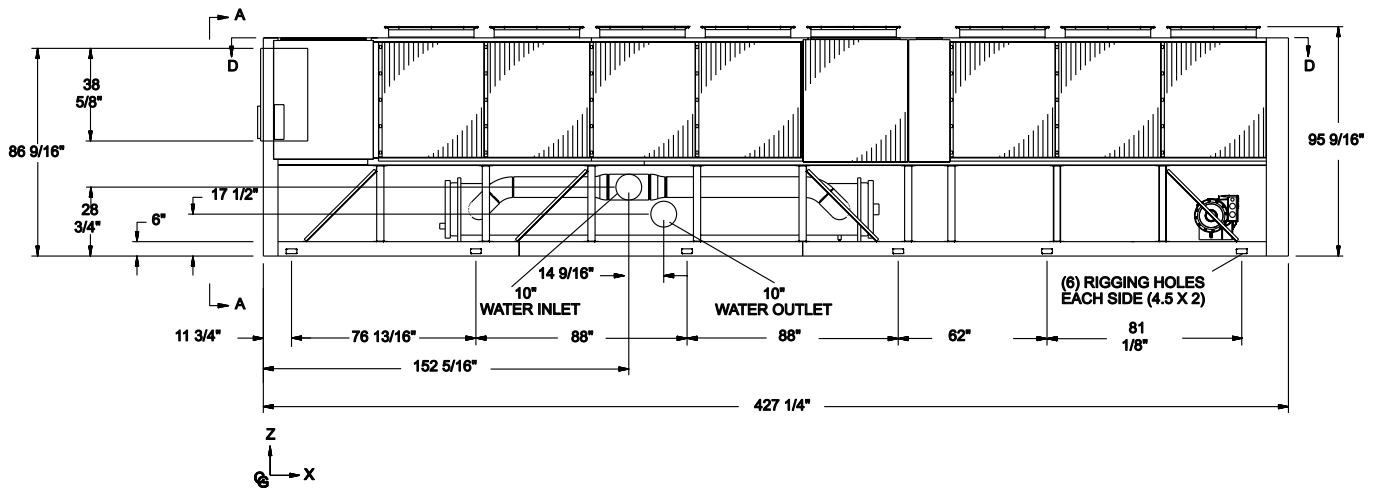
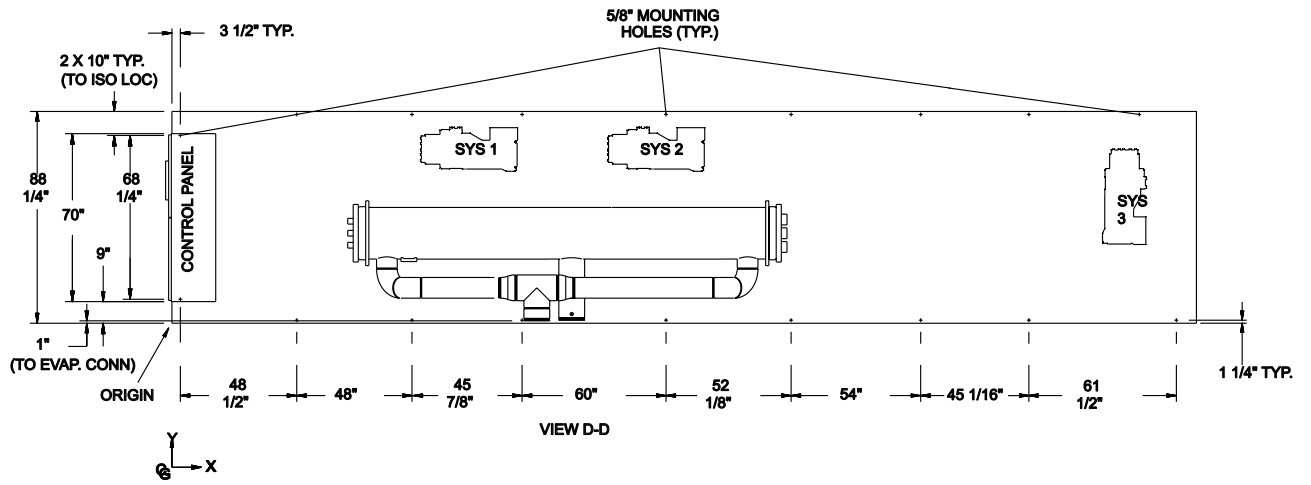

Dimensions – English

YCAV0307S/P

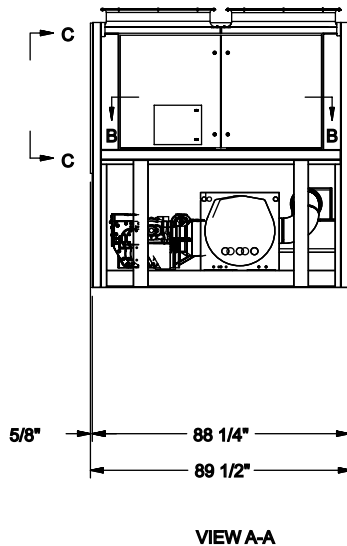
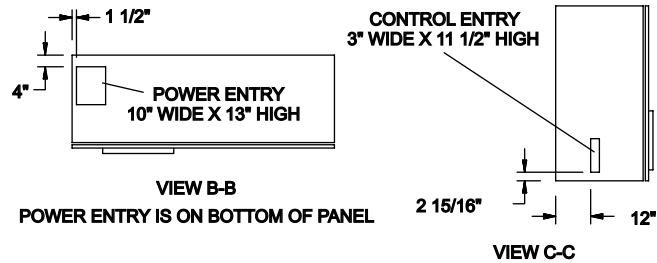

Notes:
1. Placement on a level surface free of obstructions (including snow, for winter operation) or air recirculation ensures rated performance, reliable operation and ease of maintenance. Site restrictions may compromise minimum clearances indicated below, resulting in unpredictable air patterns and possible diminished performance. York's unit controls will optimize operation without nuisance high pressure safety cutout; however, the system designer must consider potential performance degradation. Access to the unit control center assumes the unit is no higher than on spring isolators. Recommended minimum clearances: side to wall - 6'; rear to wall - 6'; control panel end to wall - 4'; top - no obstructions allowed; distance between adjacent units - 10'. No more than one adjacent wall may be higher than the unit.

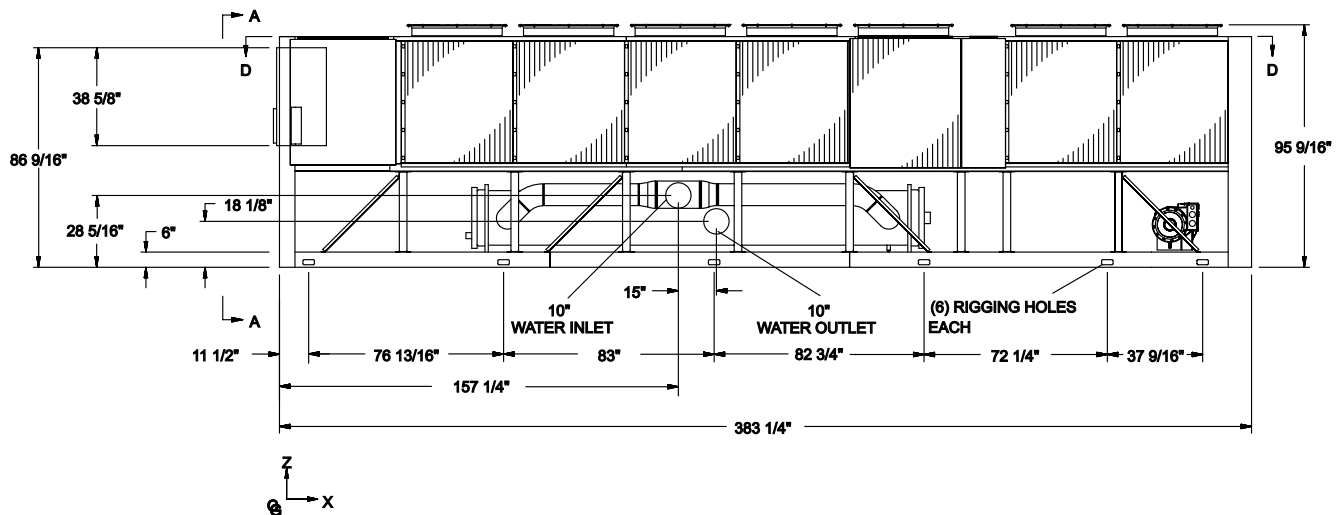
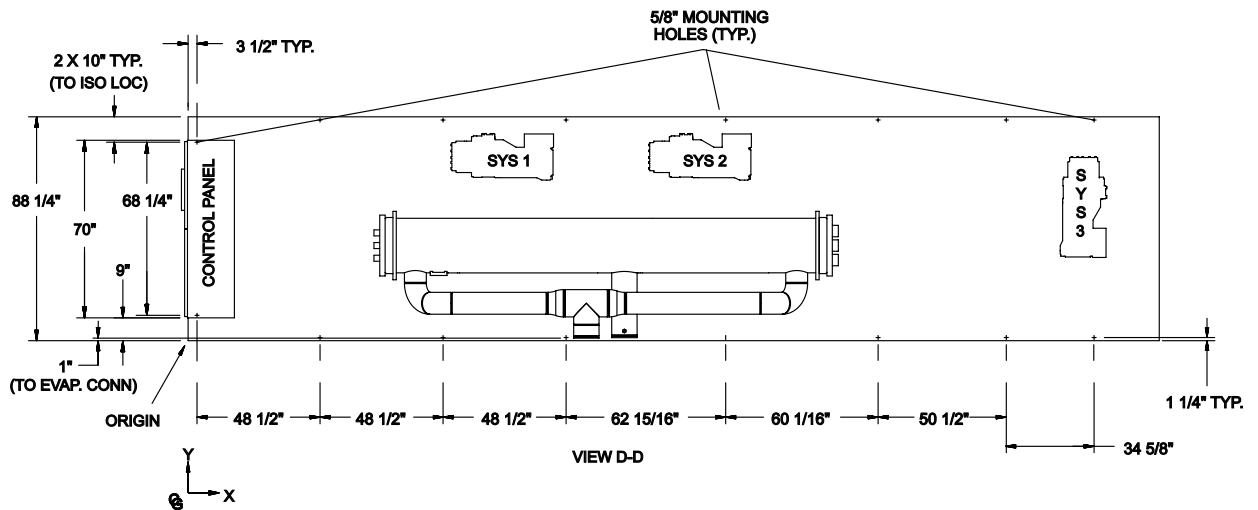

Dimensions – English

YCAV0327E/V, 0357S/P

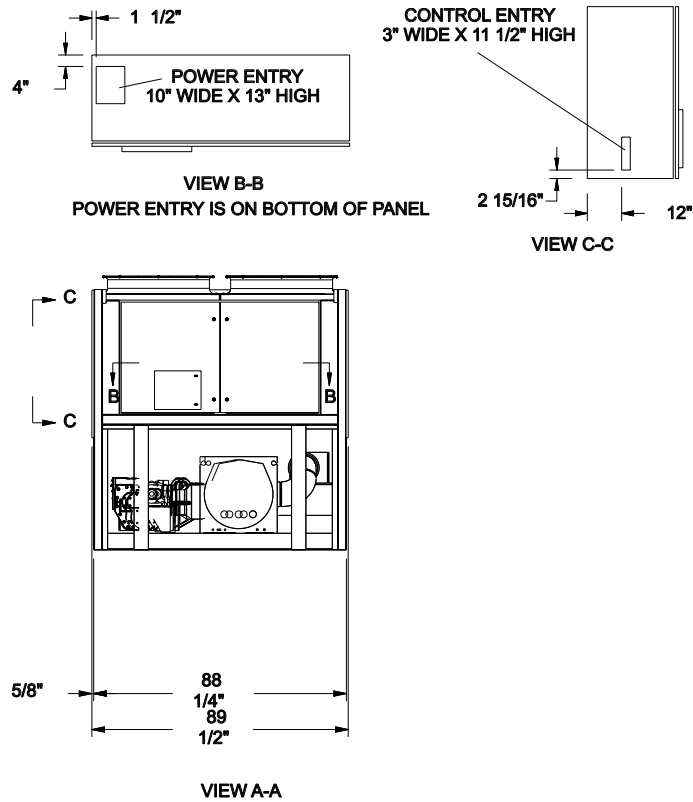

POWER: SINGLE POINT WITH TERMINAL BLOCK

Notes:
 1. Placement on a level surface free of obstructions (including snow, for winter operation) or air recirculation ensures rated performance, reliable operation and ease of maintenance. Site restrictions may compromise minimum clearances indicated below, resulting in unpredictable air patterns and possible diminished performance. York's unit controls will optimize operation without nuisance high pressure safety cutout; however, the system designer must consider potential performance degradation. Access to the unit control center assumes the unit is no higher than on spring isolators. Recommended minimum clearances: side to wall - 6'; rear to wall - 6'; control panel end to wall - 4'; top - no obstructions allowed; distance between adjacent units - 10'. No more than one adjacent wall may be higher than the unit.

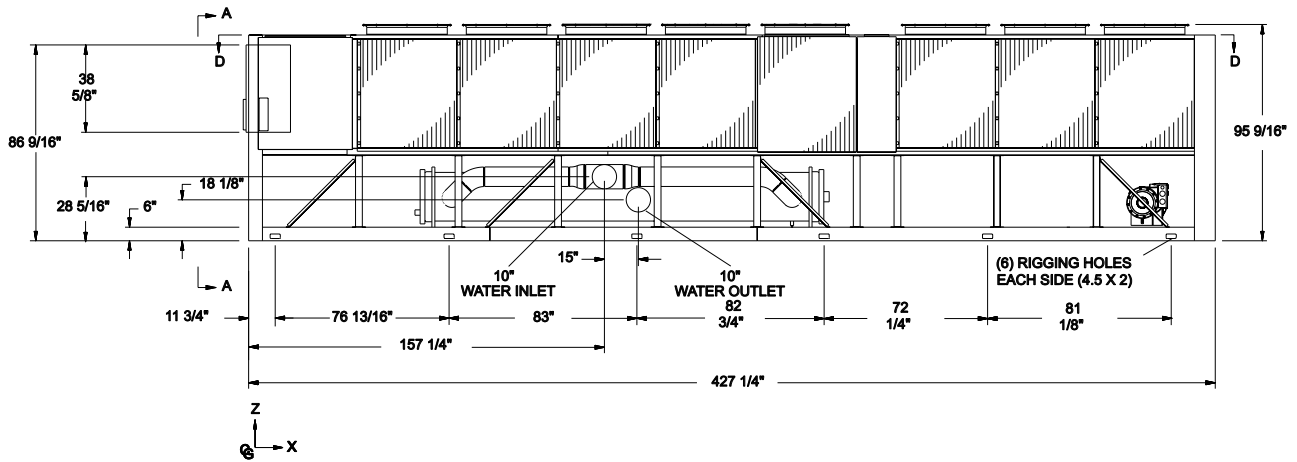
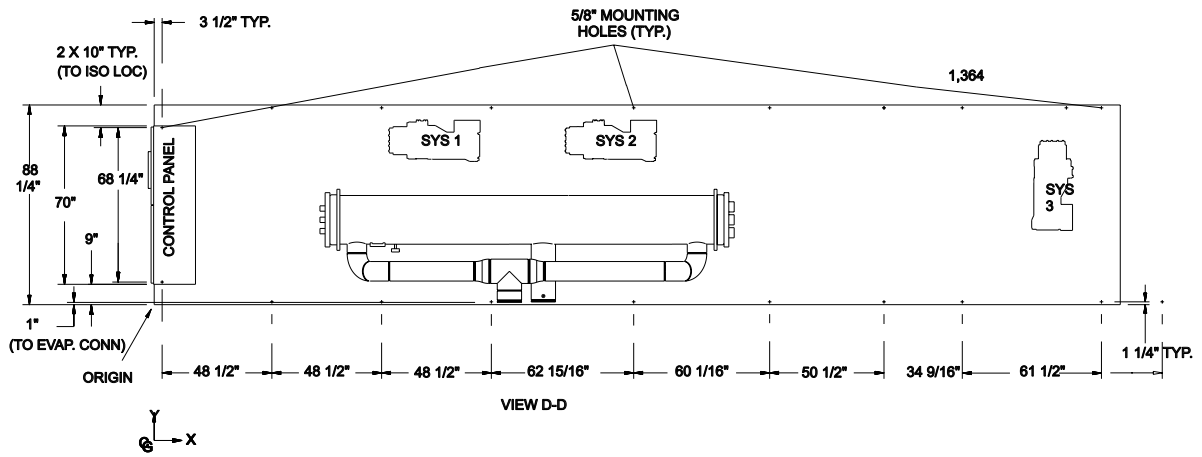

Dimensions – English

YCAV0357E/V, 0397S/P

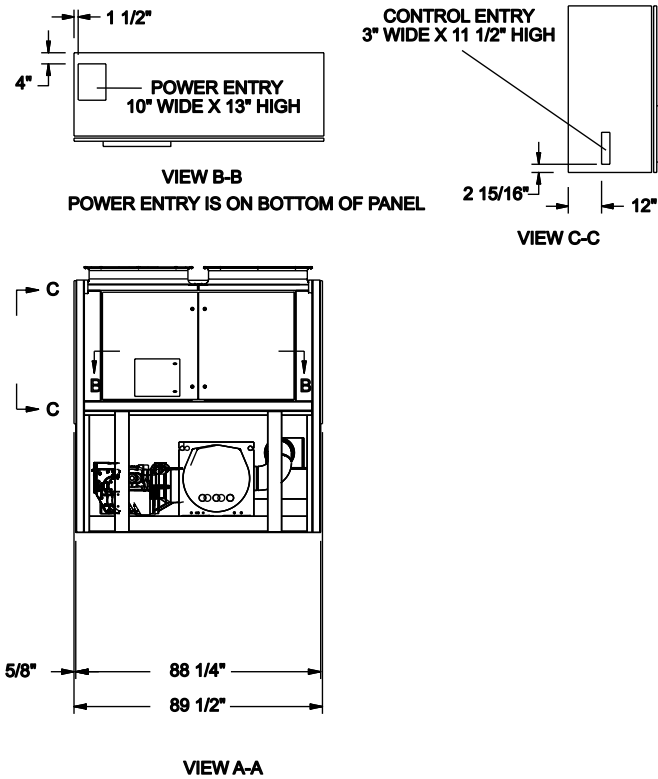

POWER: SINGLE POINT WITH TERMINAL BLOCK

Notes:
1. Placement on a level surface free of obstructions (including snow, for winter operation) or air recirculation ensures rated performance, reliable operation and ease of maintenance. Site restrictions may compromise minimum clearances indicated below, resulting in unpredictable air patterns and possible diminished performance. York's unit controls will optimize operation without nuisance high pressure safety cutout; however, the system designer must consider potential performance degradation. Access to the unit control center assumes the unit is no higher than on spring isolators. Recommended minimum clearances: side to wall - 6'; rear to wall - 6'; control panel end to wall - 4'; top - no obstructions allowed; distance between adjacent units - 10'. No more than one adjacent wall may be higher than the unit.

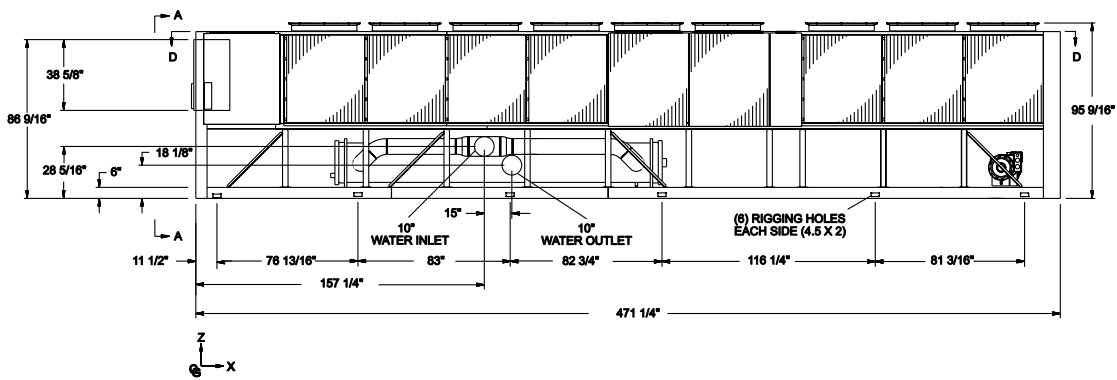
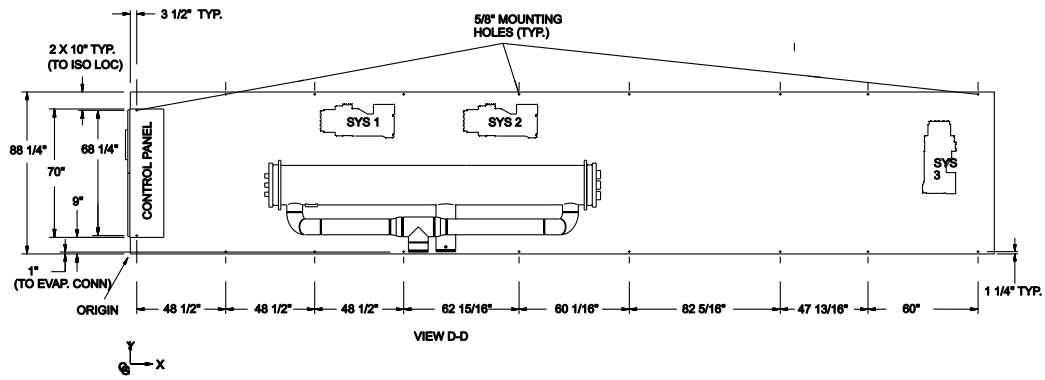

Dimensions – English

YCAV0397E/V, 0417S/P, 1429E/V, 1549S/P

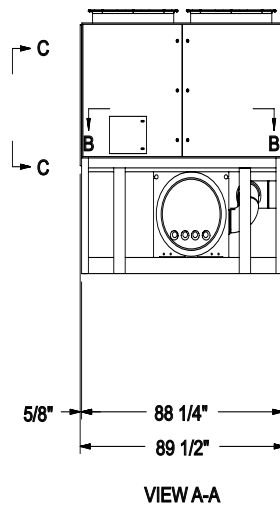
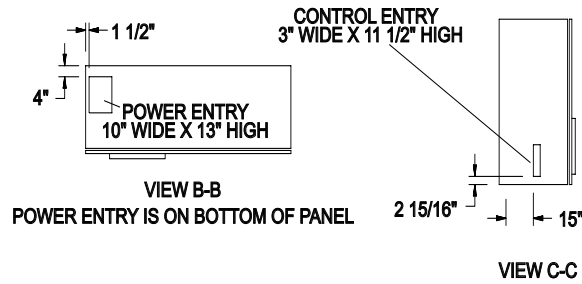

Notes:
 1. Placement on a level surface free of obstructions (including snow, for winter operation) or air recirculation ensures rated performance, reliable operation and ease of maintenance. Site restrictions may compromise minimum clearances indicated below, resulting in unpredictable air patterns and possible diminished performance. York's unit controls will optimize operation without nuisance high pressure safety cutout; however, the system designer must consider potential performance degradation. Access to the unit control center assumes the unit is no higher than on spring isolators. Recommended minimum clearances: side to wall - 6'; rear to wall - 6'; control panel end to wall - 4'; top - no obstructions allowed; distance between adjacent units - 10'. No more than one adjacent wall may be higher than the unit.

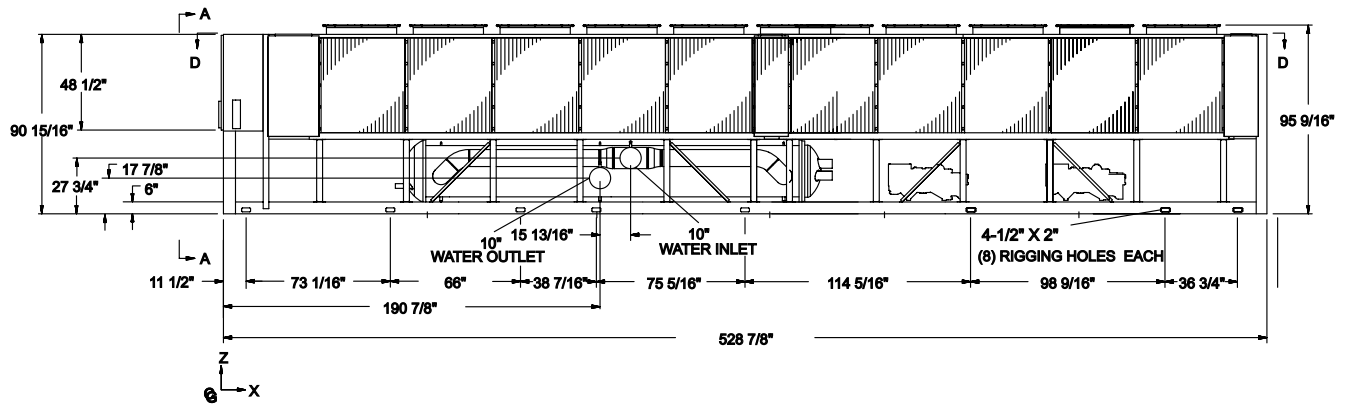
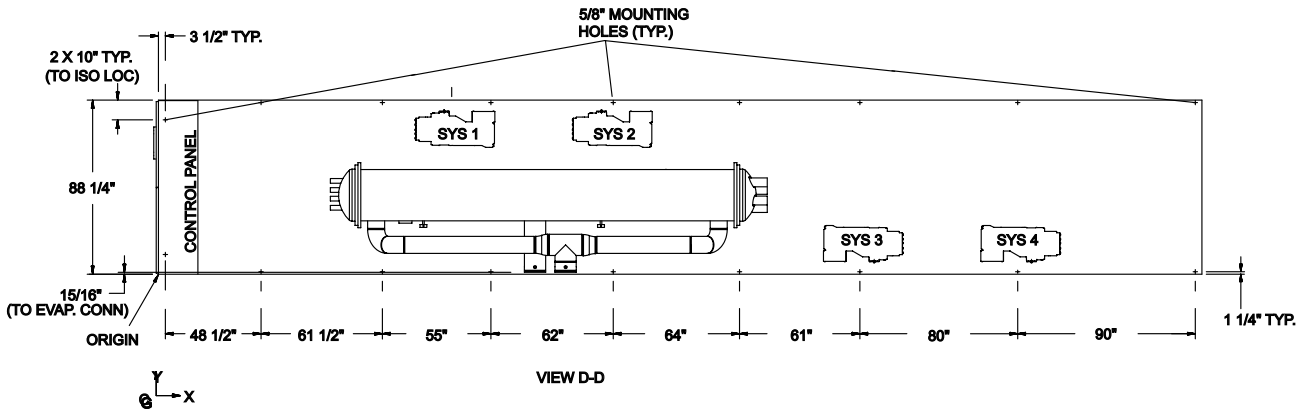

Dimensions – English

YCAV0417E/V, 0477S/P, 1549E/V, 1739S/P

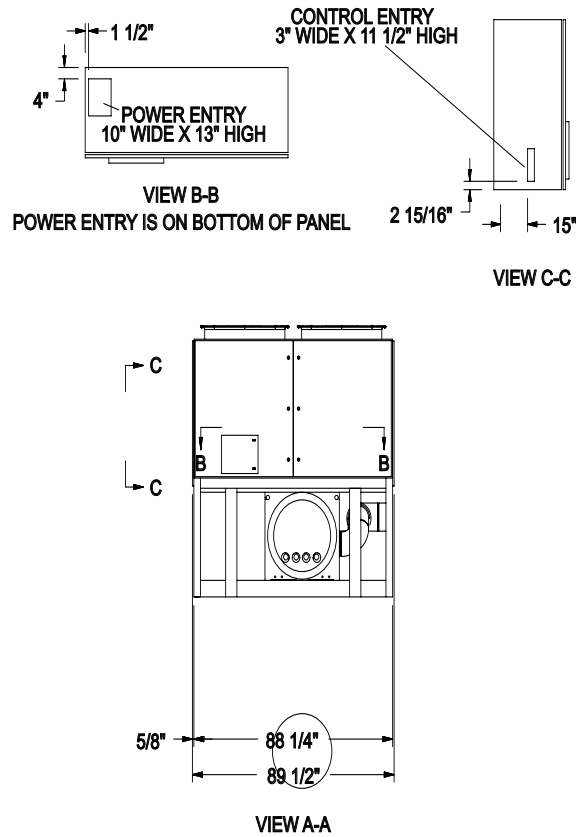

Notes:
1. Placement on a level surface free of obstructions (including snow, for winter operation) or air recirculation ensures rated performance, reliable operation and ease of maintenance. Site restrictions may compromise minimum clearances indicated below, resulting in unpredictable air patterns and possible diminished performance. York's unit controls will optimize operation without nuisance high pressure safety cutout; however, the system designer must consider potential performance degradation. Access to the unit control center assumes the unit is no higher than on spring isolators. Recommended minimum clearances: side to wall - 6'; rear to wall - 6'; control panel end to wall - 4'; top - no obstructions allowed; distance between adjacent units - 10'. No more than one adjacent wall may be higher than the unit.

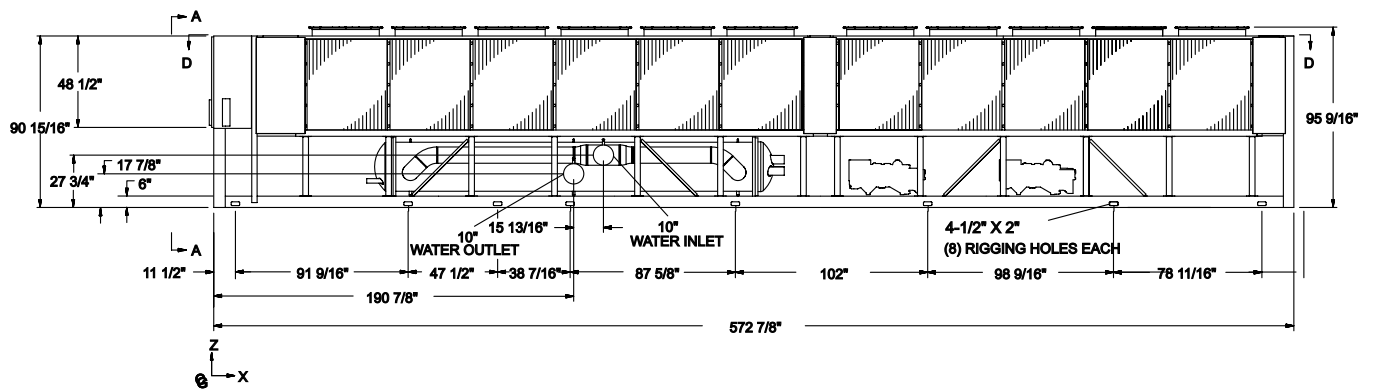
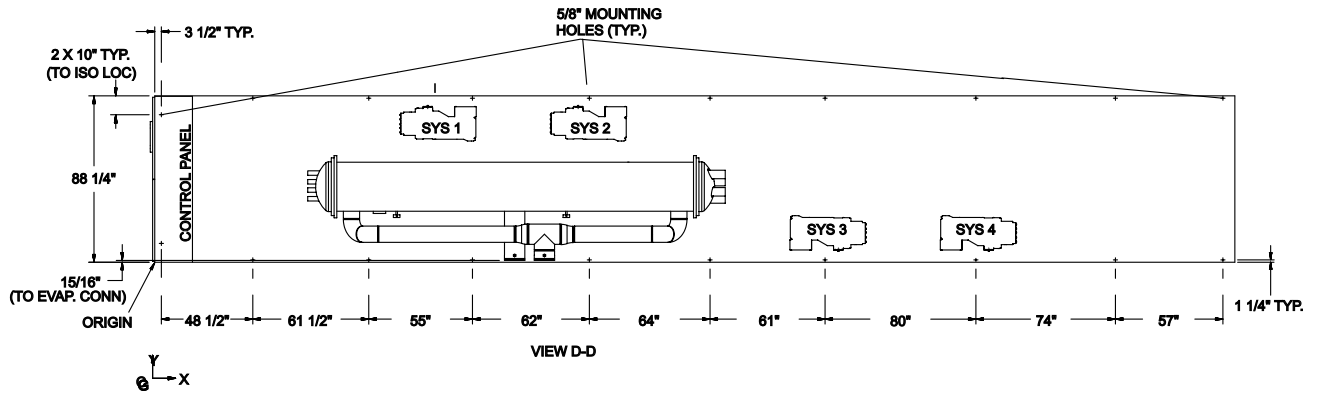

Dimensions – English

YCAV0457S/P, 1649S/P

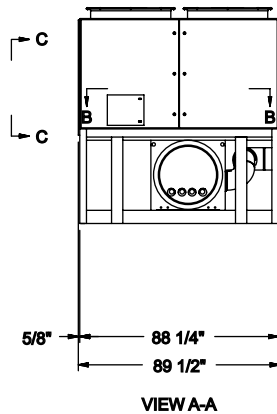
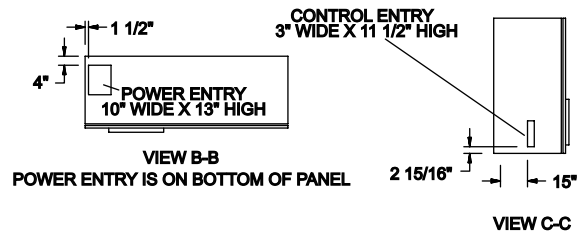

Notes:
1. Placement on a level surface free of obstructions (including snow, for winter operation) or air recirculation ensures rated performance, reliable operation and ease of maintenance. Site restrictions may compromise minimum clearances indicated below, resulting in unpredictable air patterns and possible diminished performance. York's unit controls will optimize operation without nuisance high pressure safety cutout; however, the system designer must consider potential performance degradation. Access to the unit control center assumes the unit is no higher than on spring isolators. Recommended minimum clearances: side to wall - 6'; rear to wall - 6'; control panel end to wall - 4'; top - no obstructions allowed; distance between adjacent units - 10'. No more than one adjacent wall may be higher than the unit.

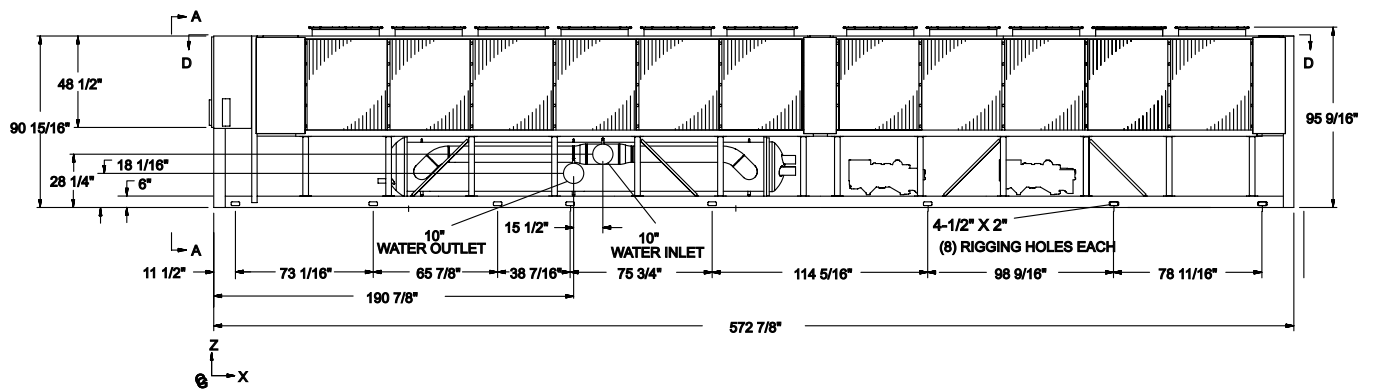
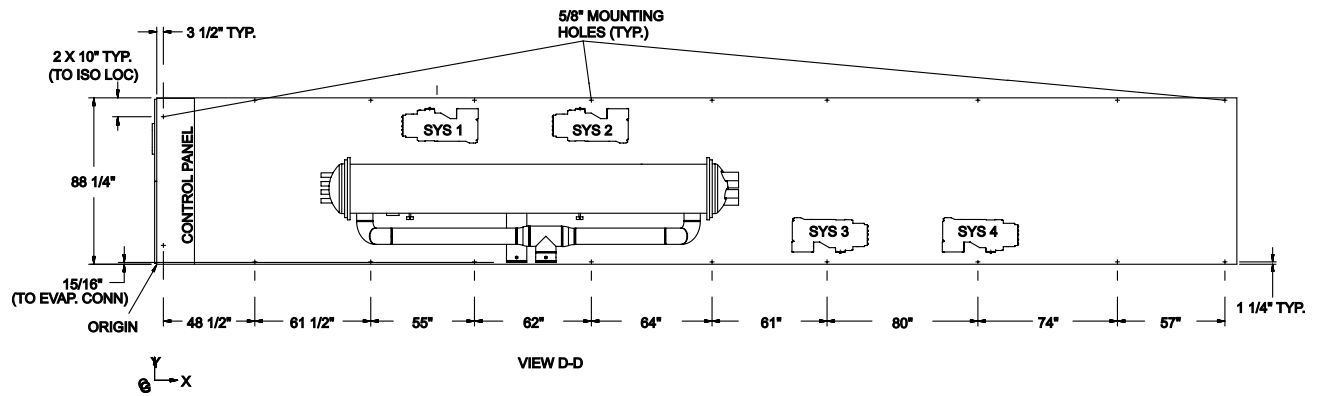

Dimensions – English

YCAV0477E/V, 0507S/P, 0527S/P, 1739E/V, 1829S/P, 1909S/P

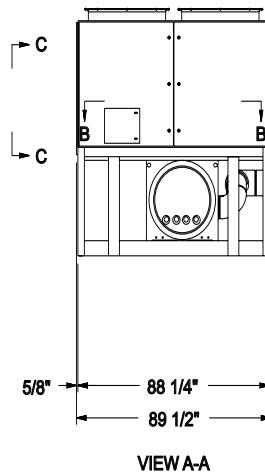
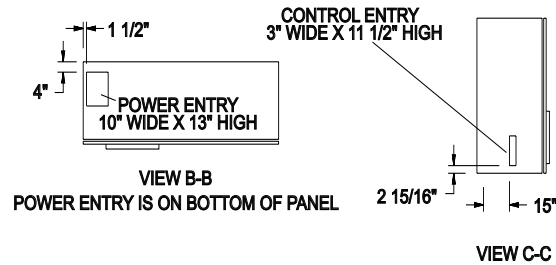

Notes:
1. Placement on a level surface free of obstructions (including snow, for winter operation) or air recirculation ensures rated performance, reliable operation and ease of maintenance. Site restrictions may compromise minimum clearances indicated below, resulting in unpredictable air patterns and possible diminished performance. York's unit controls will optimize operation without nuisance high pressure safety cutout; however, the system designer must consider potential performance degradation. Access to the unit control center assumes the unit is no higher than on spring isolators. Recommended minimum clearances: side to wall - 6'; rear to wall - 6'; control panel end to wall - 4'; top - no obstructions allowed; distance between adjacent units - 10'. No more than one adjacent wall may be higher than the unit.

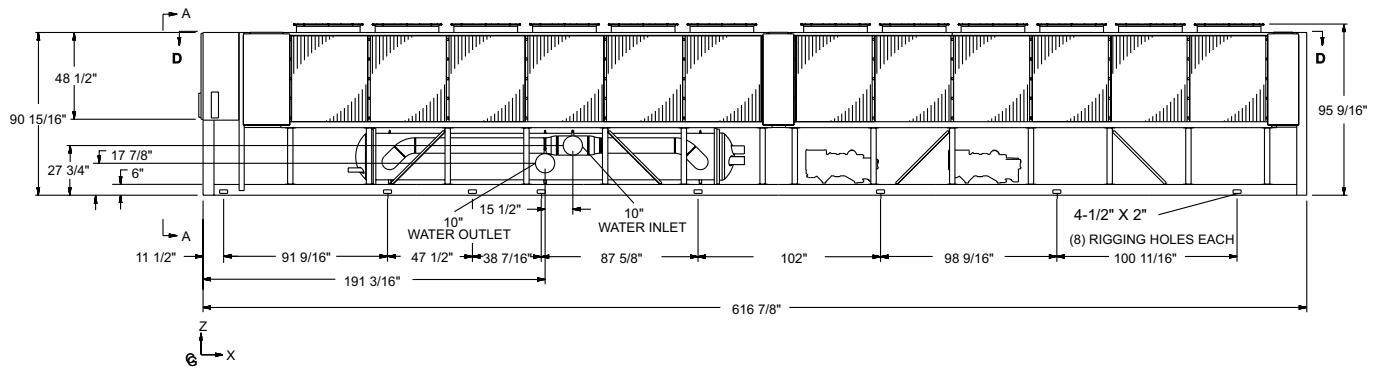
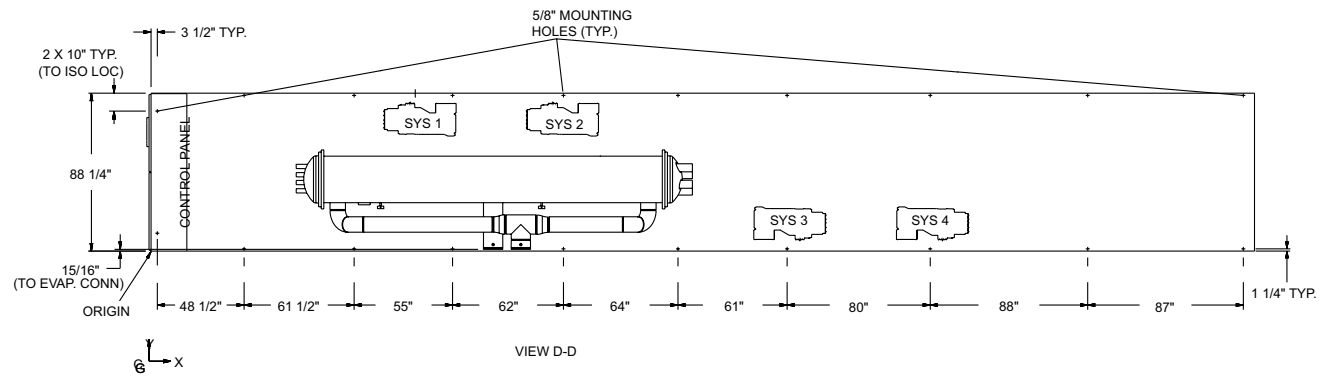

Dimensions – SI

YCAV0157S/P

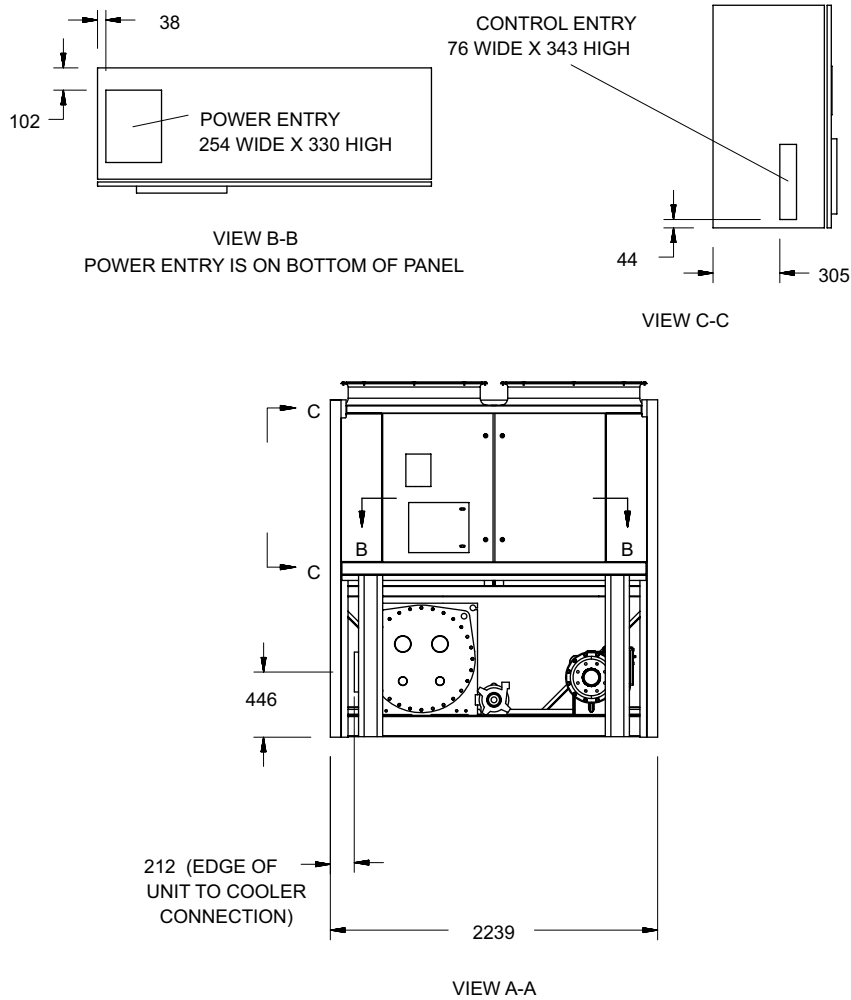

Notes:
1. Placement on a level surface free of obstructions (including snow, for winter operation) or air recirculation ensures rated performance, reliable operation and ease of maintenance. Site restrictions may compromise minimum clearances indicated below, resulting in unpredictable air patterns and possible diminished performance. York's unit controls will optimize operation without nuisance high pressure safety cutout; however, the system designer must consider potential performance degradation. Access to the unit control center assumes the unit is no higher than on spring isolators. Recommended minimum clearances: side to wall - 2m; rear to wall - 2m; control panel end to wall - 1.2m; top - no obstructions allowed; distance between adjacent units - 3m. No more than one adjacent wall may be higher than the unit.

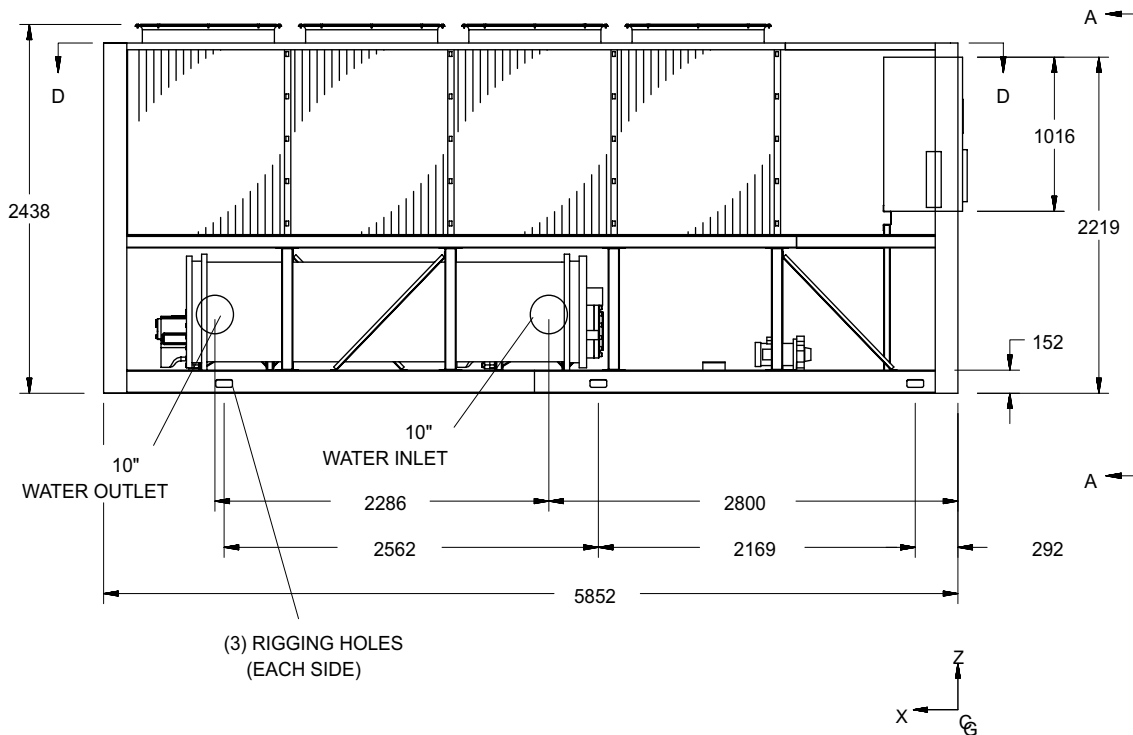
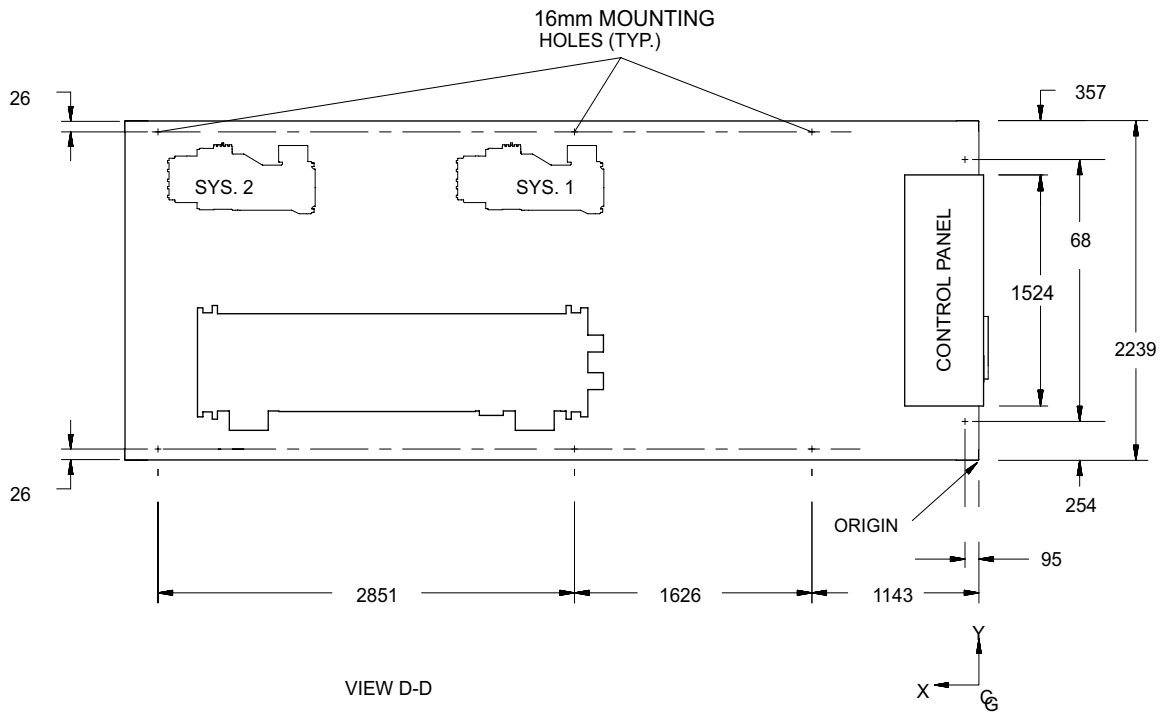

Dimensions – SI

YCAV0157E/V, 0177S/P

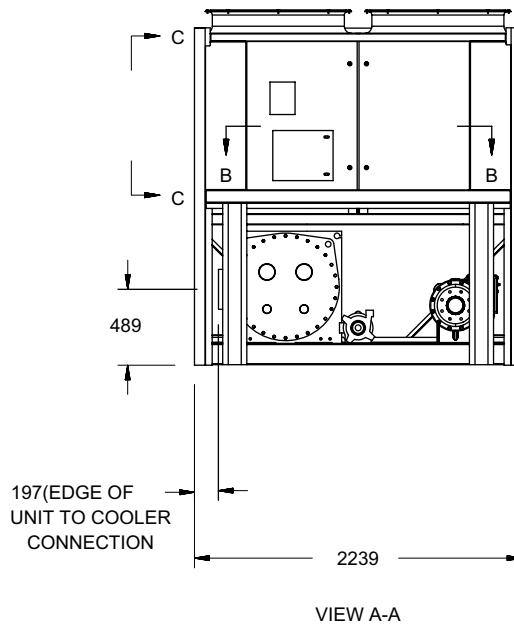
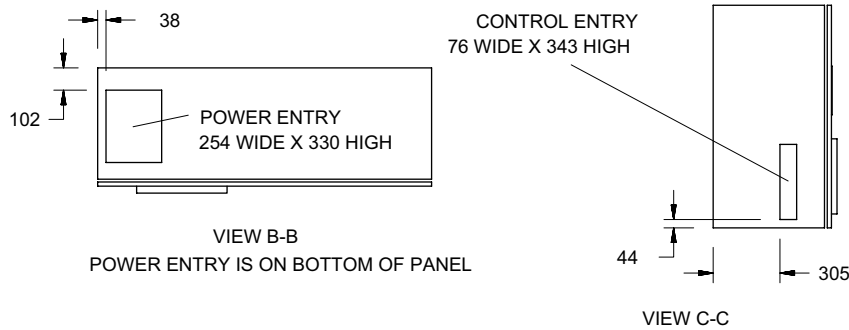

Notes:
1. Placement on a level surface free of obstructions (including snow, for winter operation) or air recirculation ensures rated performance, reliable operation and ease of maintenance. Site restrictions may compromise minimum clearances indicated below, resulting in unpredictable air patterns and possible diminished performance. York's unit controls will optimize operation without nuisance high pressure safety cutout; however, the system designer must consider potential performance degradation. Access to the unit control center assumes the unit is no higher than on spring isolators. Recommended minimum clearances: side to wall - 2m; rear to wall - 2m; control panel end to wall - 1.2m; top - no obstructions allowed; distance between adjacent units - 3m. No more than one adjacent wall may be higher than the unit.

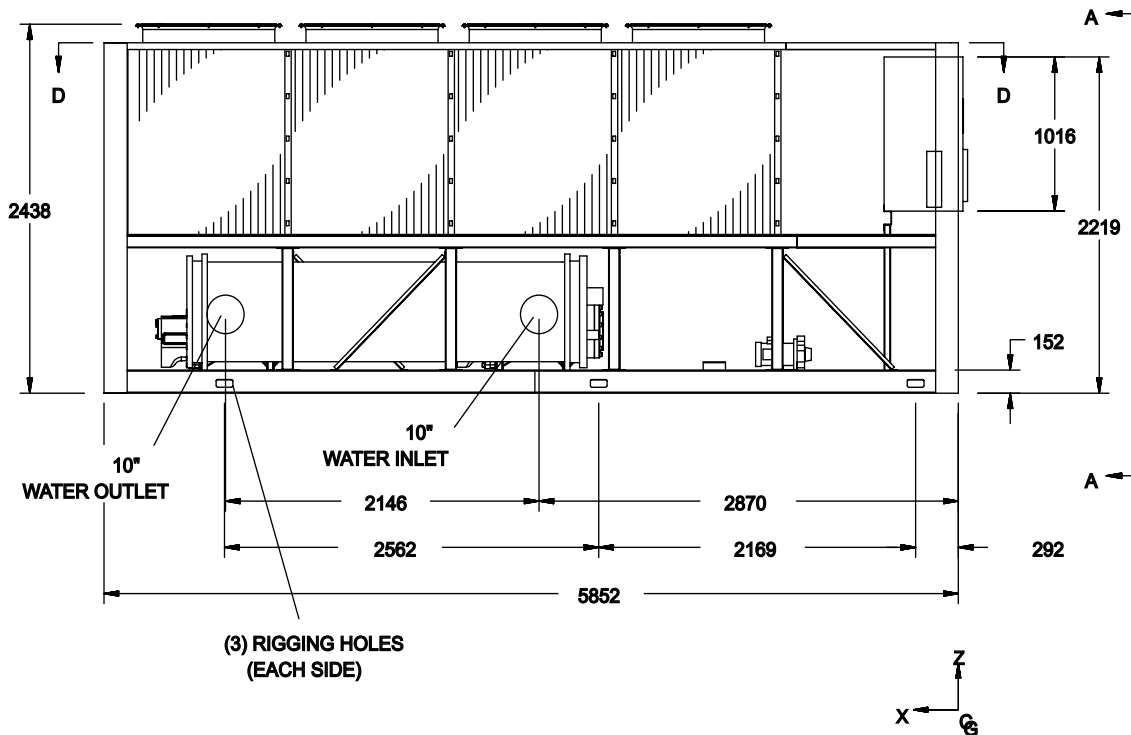
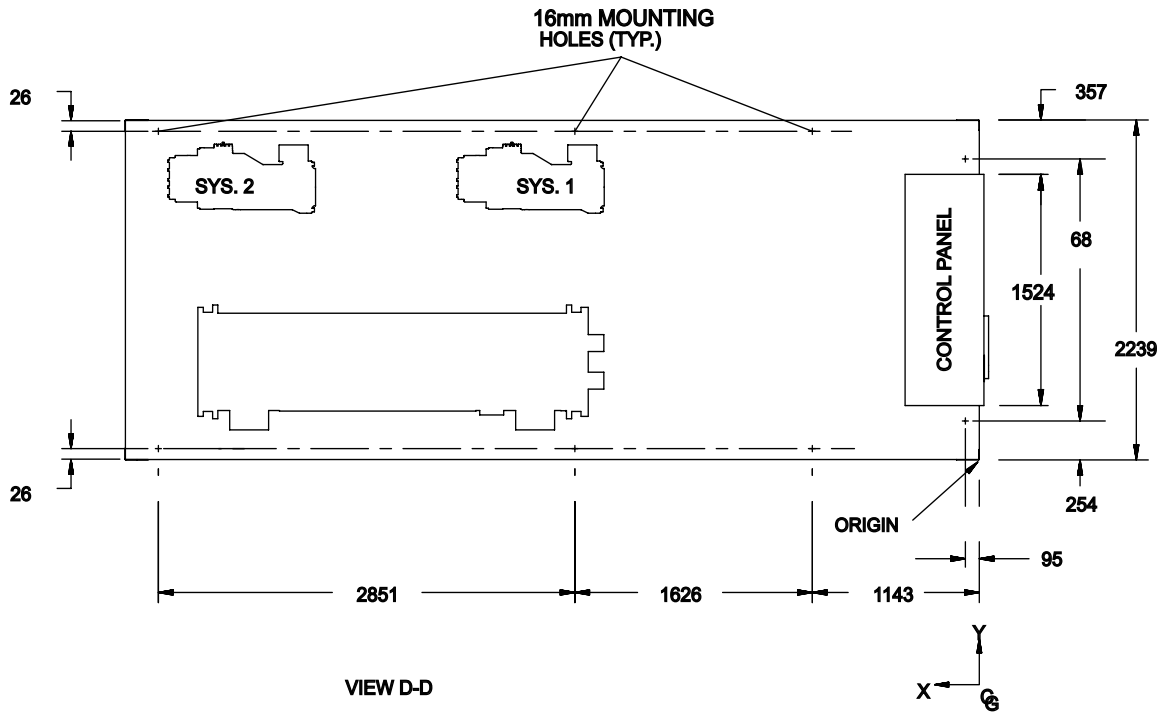

Dimensions – SI

YCAV0177E/V, 0187S/P, 0187E/V

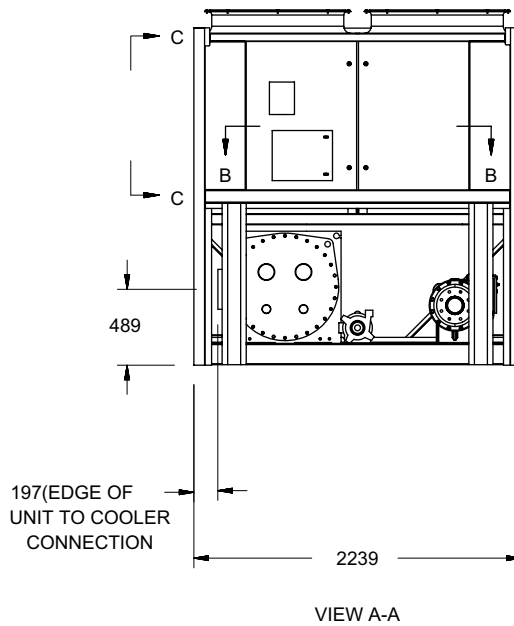
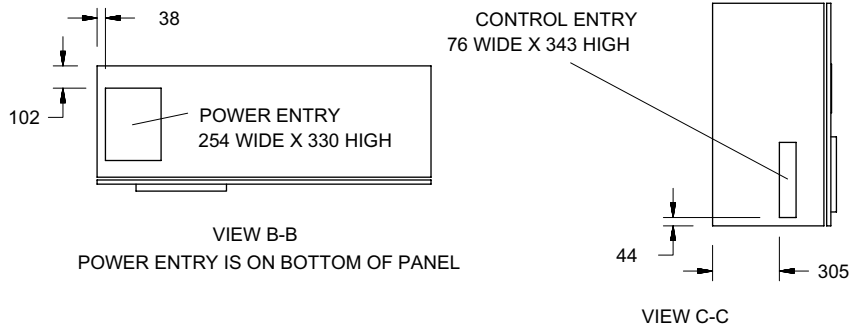

Notes:

1. Placement on a level surface free of obstructions (including snow, for winter operation) or air recirculation ensures rated performance, reliable operation and ease of maintenance. Site restrictions may compromise minimum clearances indicated below, resulting in unpredictable air patterns and possible diminished performance. York's unit controls will optimize operation without nuisance high pressure safety cutout; however, the system designer must consider potential performance degradation. Access to the unit control center assumes the unit is no higher than on spring isolators. Recommended minimum clearances: side to wall - 2m; rear to wall - 2m; control panel end to wall - 1.2m; top - no obstructions allowed; distance between adjacent units - 3m. No more than one adjacent wall may be higher than the unit.

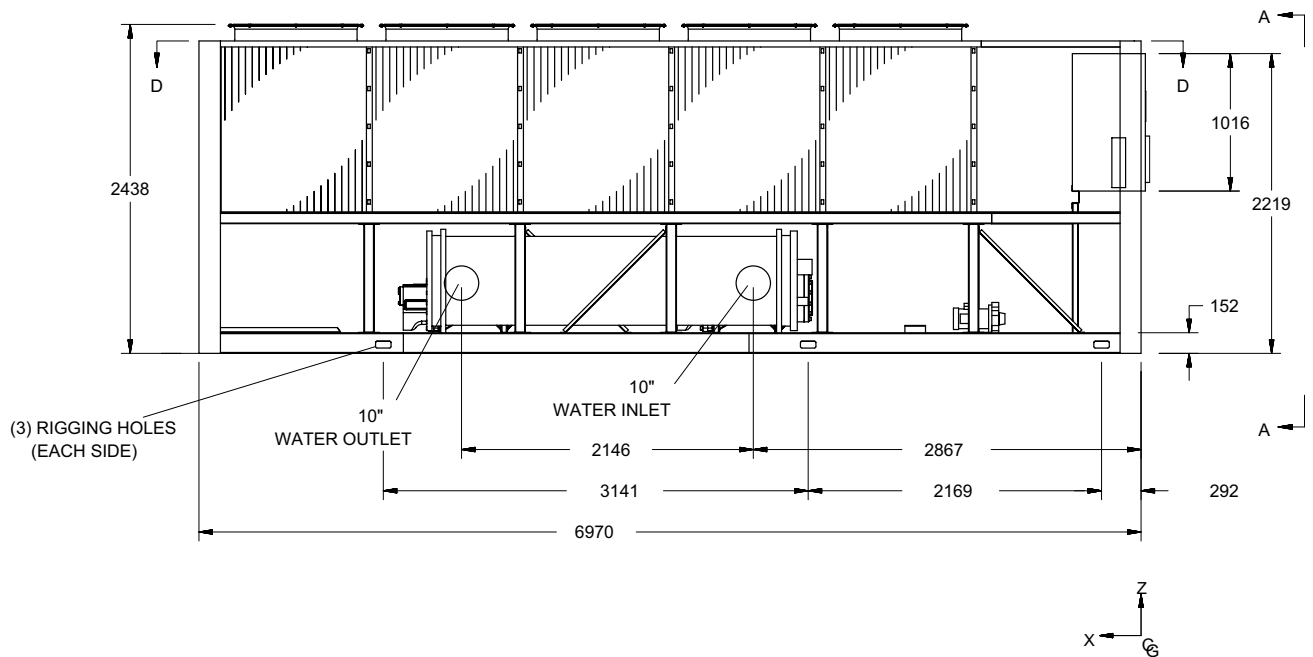
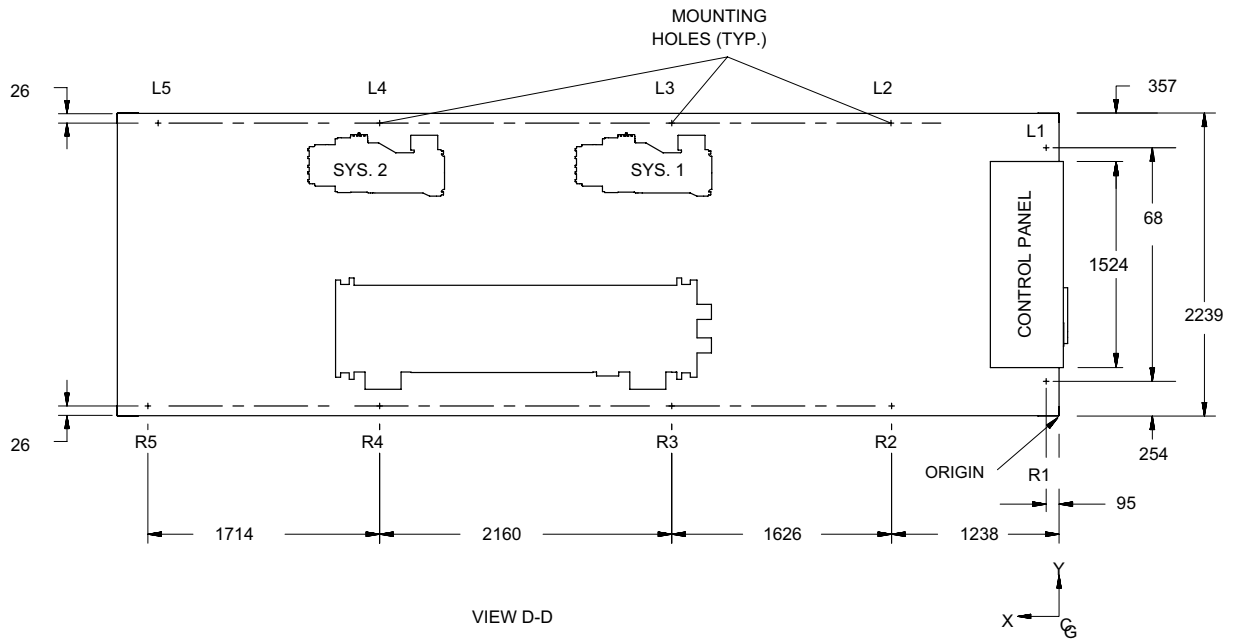

Dimensions – SI

YCAV0197E/V

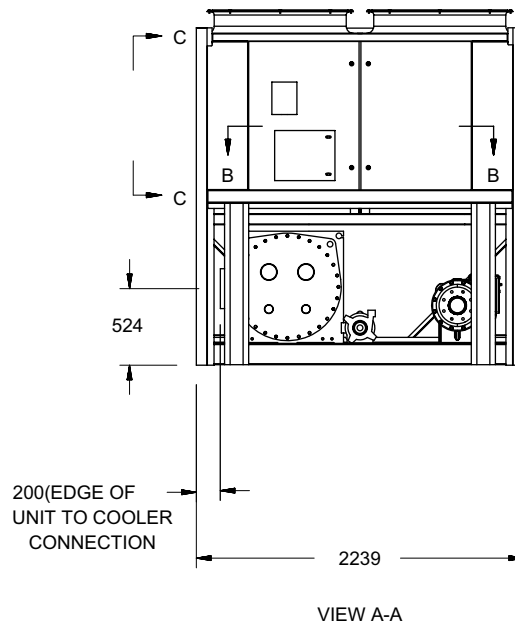
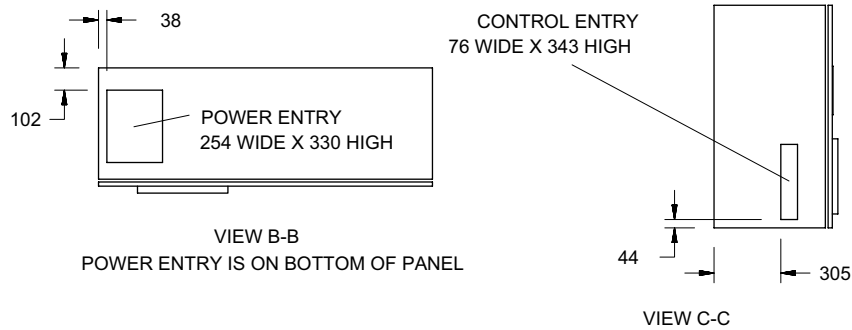

Notes:

1. Placement on a level surface free of obstructions (including snow, for winter operation) or air recirculation ensures rated performance, reliable operation and ease of maintenance. Site restrictions may compromise minimum clearances indicated below, resulting in unpredictable air patterns and possible diminished performance. York's unit controls will optimize operation without nuisance high pressure safety cutout; however, the system designer must consider potential performance degradation. Access to the unit control center assumes the unit is no higher than on spring isolators. Recommended minimum clearances: side to wall - 2m; rear to wall - 2m; control panel end to wall - 1.2m; top - no obstructions allowed; distance between adjacent units - 3m. No more than one adjacent wall may be higher than the unit.

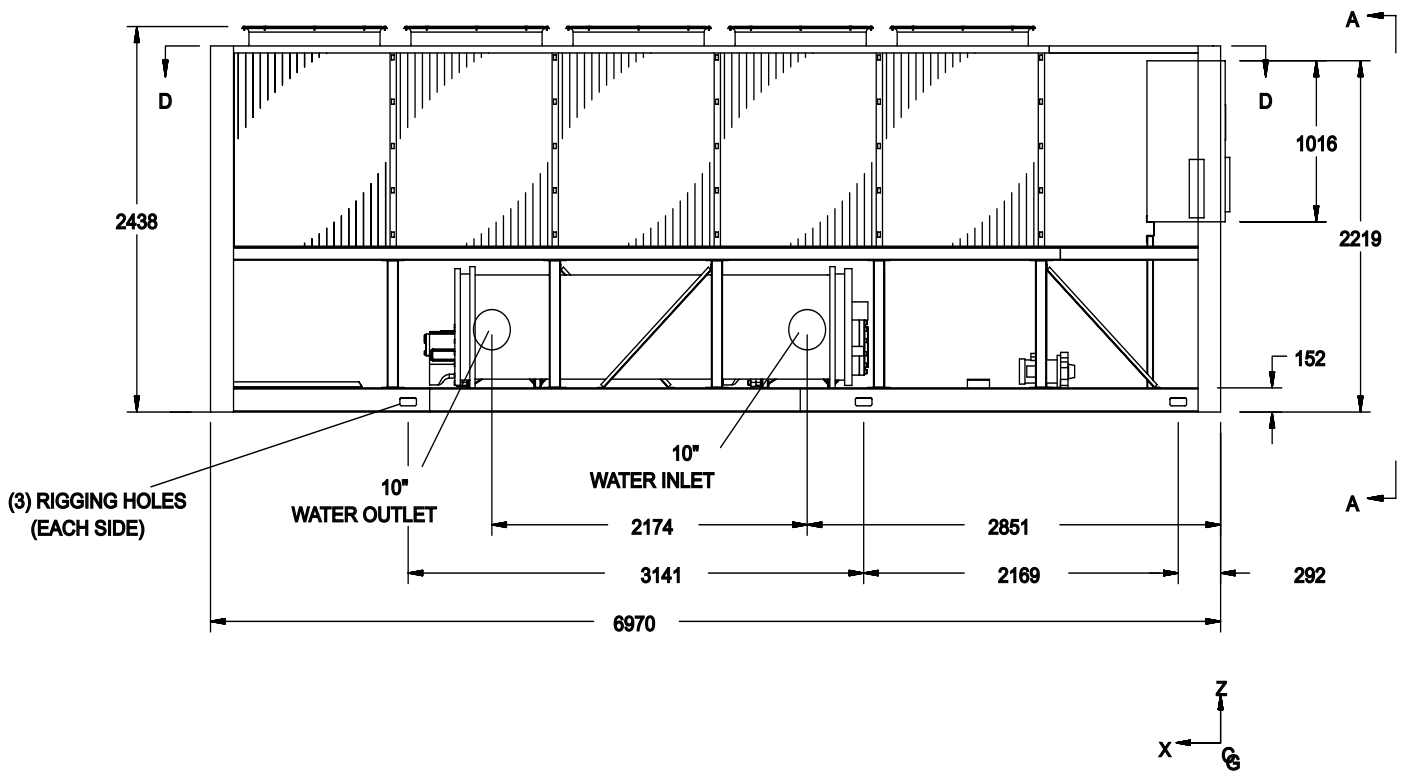
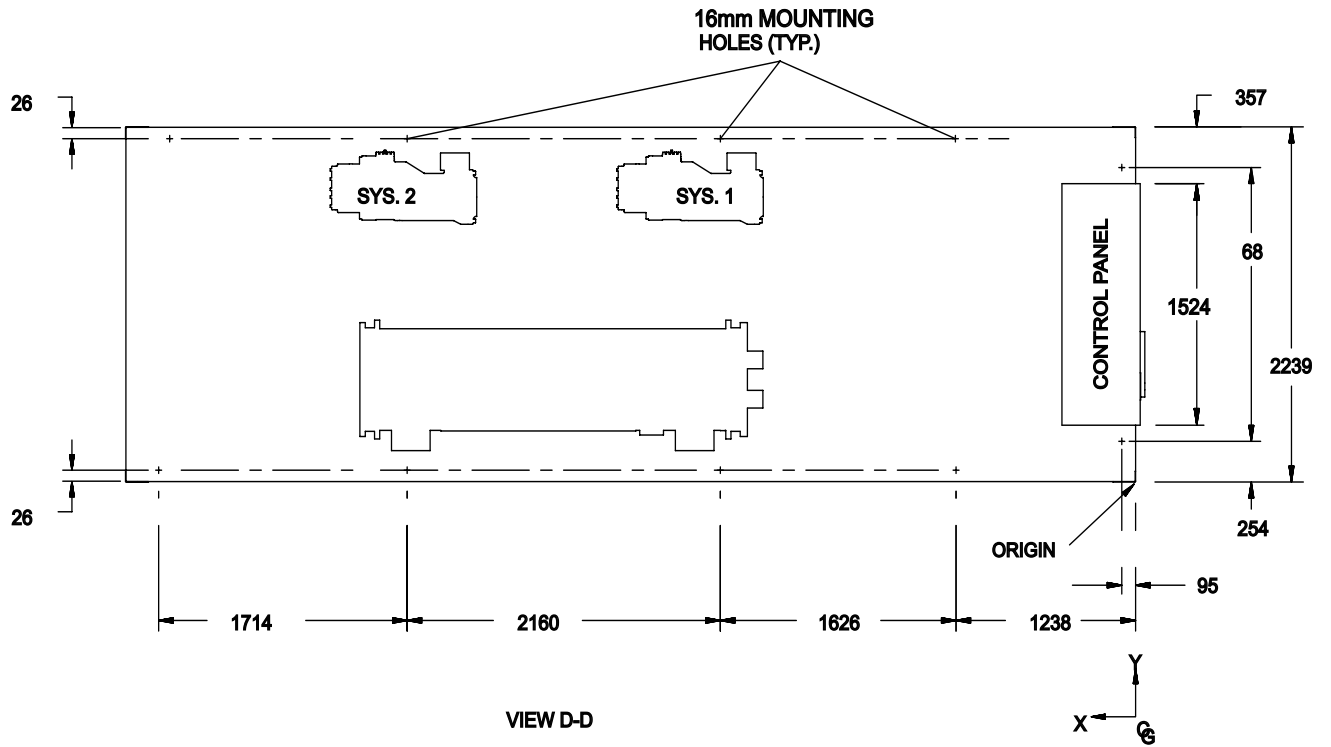

Dimensions – SI

YCAV0207S/P, 0227S/P

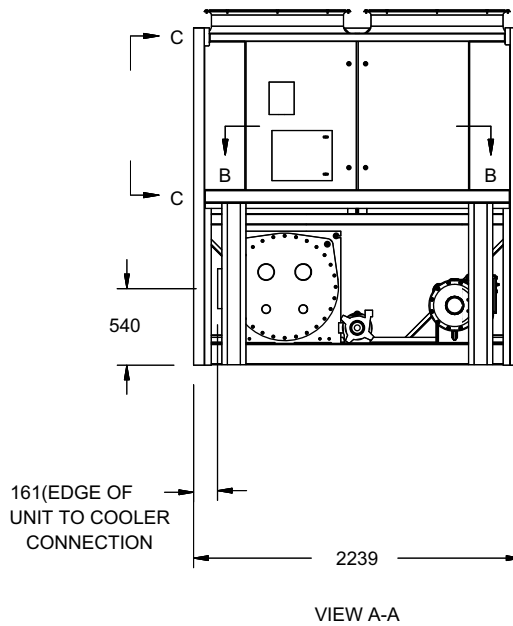
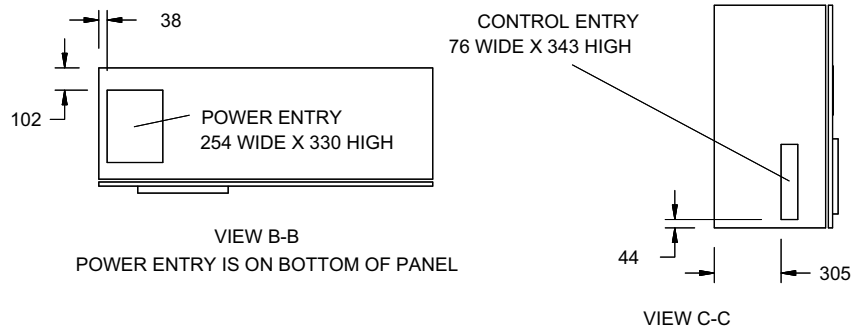

Notes:
1. Placement on a level surface free of obstructions (including snow, for winter operation) or air recirculation ensures rated performance, reliable operation and ease of maintenance. Site restrictions may compromise minimum clearances indicated below, resulting in unpredictable air patterns and possible diminished performance. York's unit controls will optimize operation without nuisance high pressure safety cutout; however, the system designer must consider potential performance degradation. Access to the unit control center assumes the unit is no higher than on spring isolators. Recommended minimum clearances: side to wall - 2m; rear to wall - 2m; control panel end to wall - 1.2m; top - no obstructions allowed; distance between adjacent units - 3m. No more than one adjacent wall may be higher than the unit.

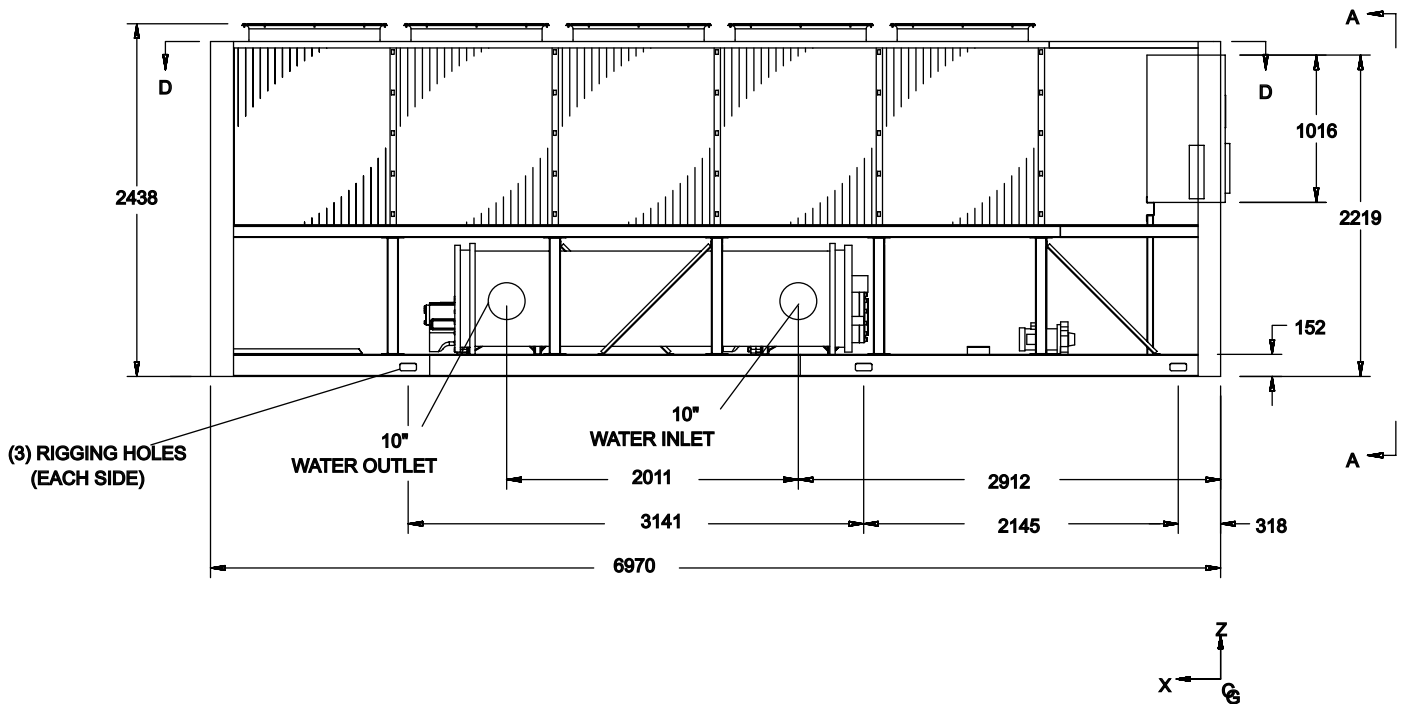
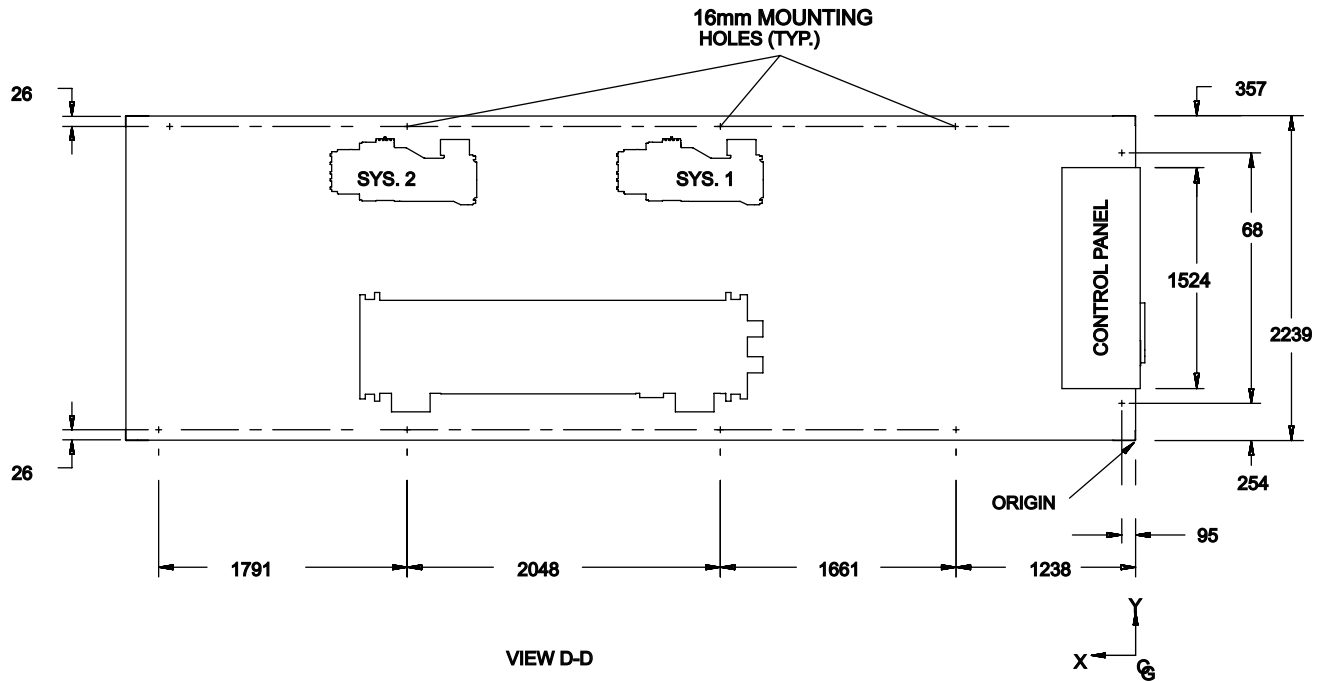

Dimensions – SI

YCAV0207E/V, 0227E/V

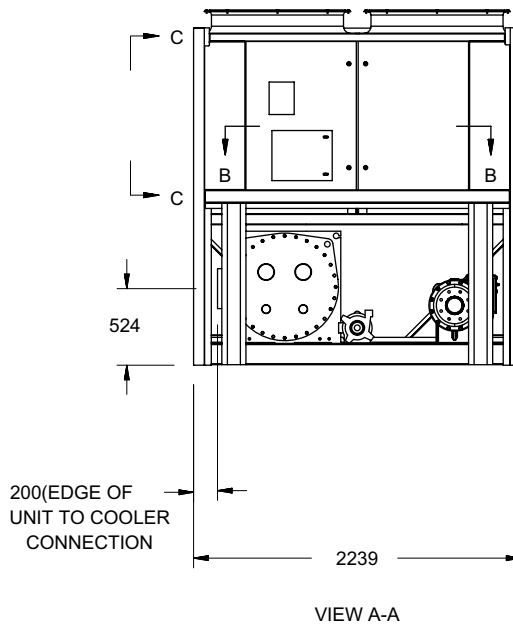
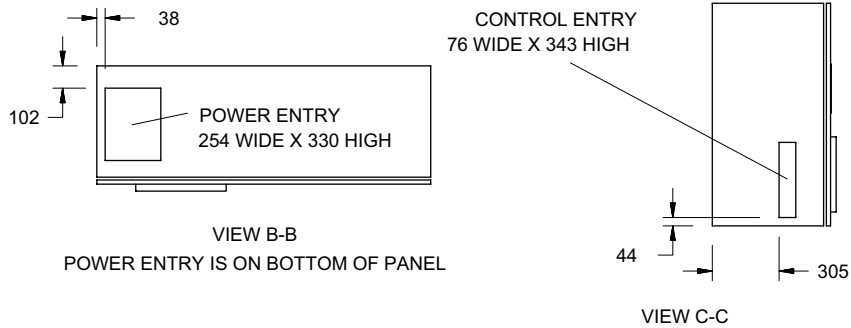

Notes:

1. Placement on a level surface free of obstructions (including snow, for winter operation) or air recirculation ensures rated performance, reliable operation and ease of maintenance. Site restrictions may compromise minimum clearances indicated below, resulting in unpredictable air patterns and possible diminished performance. York's unit controls will optimize operation without nuisance high pressure safety cutout; however, the system designer must consider potential performance degradation. Access to the unit control center assumes the unit is no higher than on spring isolators. Recommended minimum clearances: side to wall - 2m; rear to wall - 2m; control panel end to wall - 1.2m; top - no obstructions allowed; distance between adjacent units - 3m. No more than one adjacent wall may be higher than the unit.

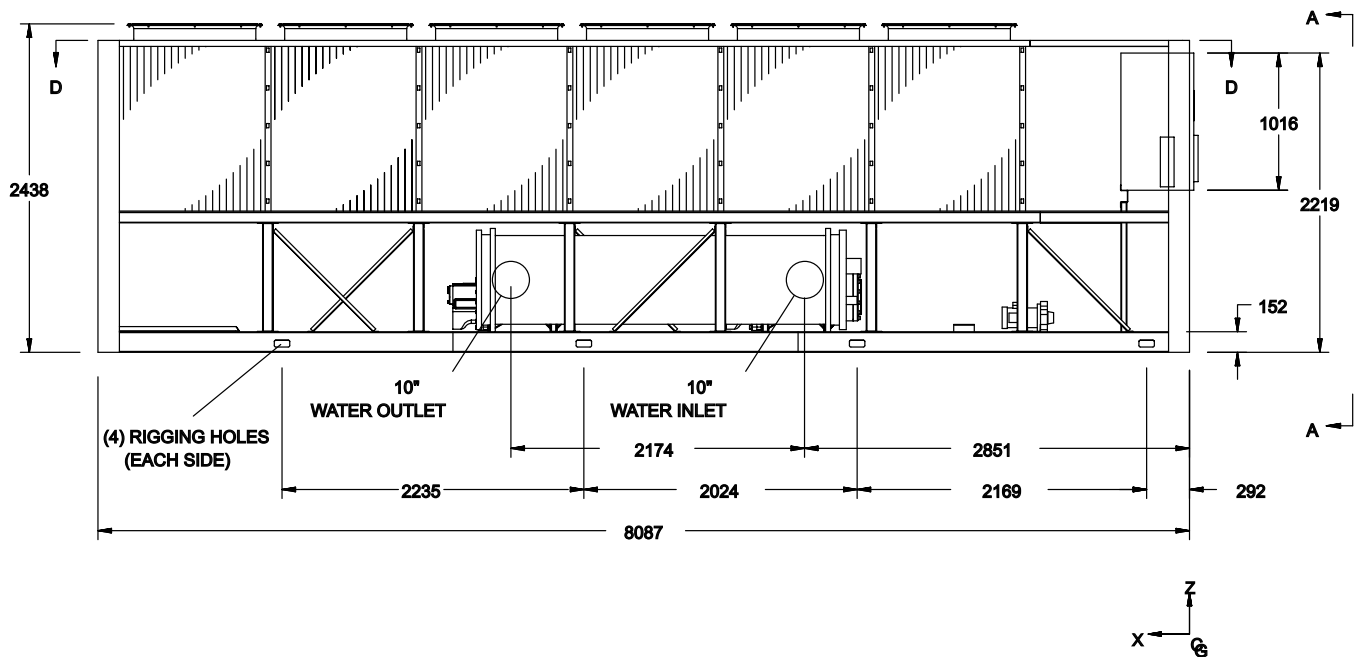
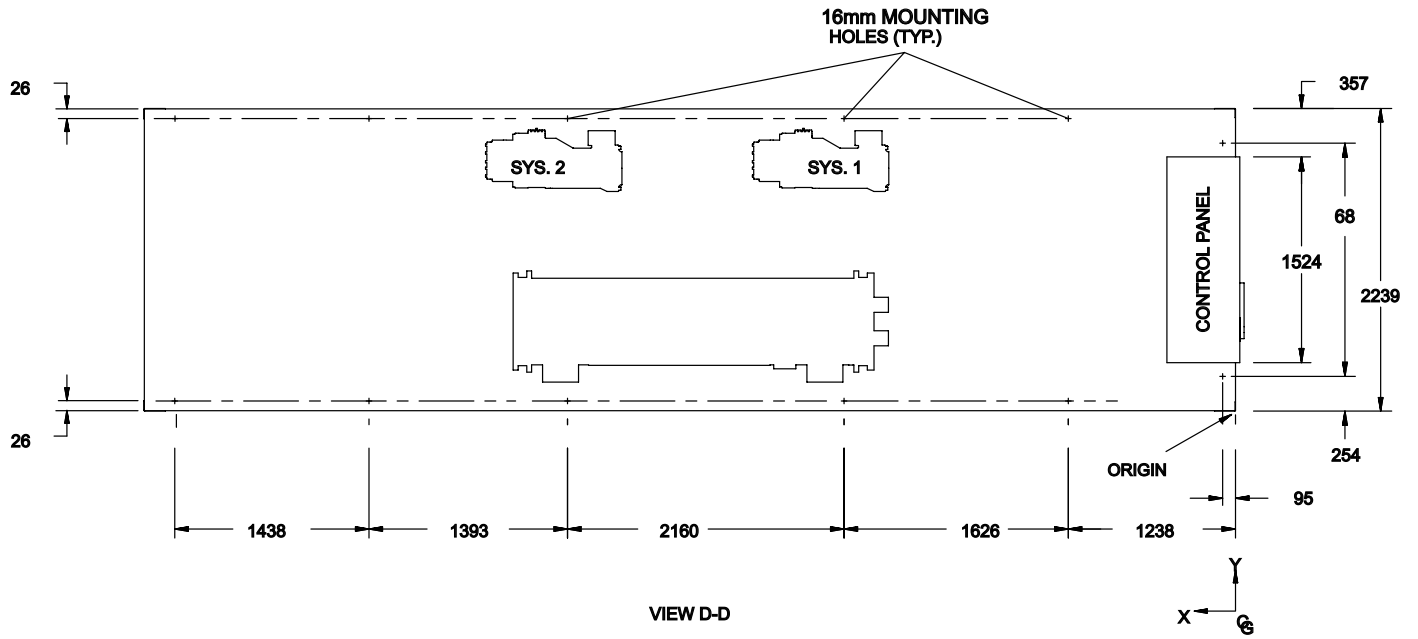

Dimensions – SI

YCAV0247S/P, 0247E/V, 0267S/P

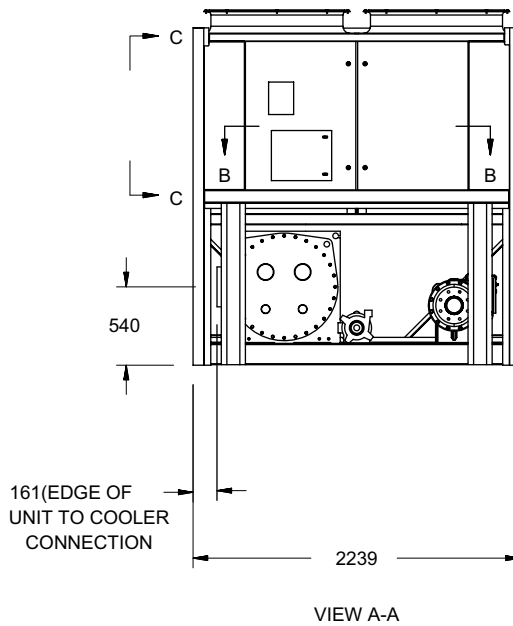
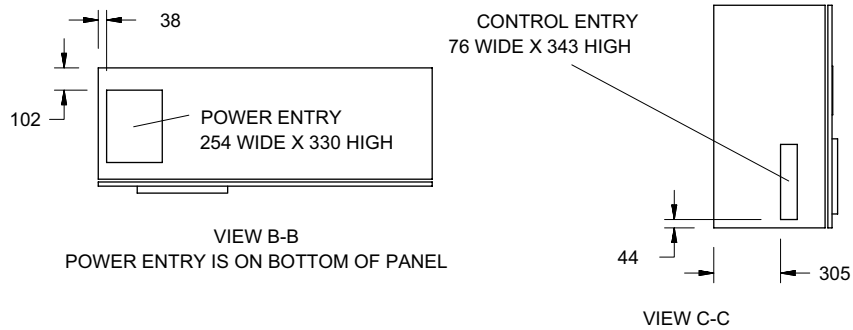

Notes:

1. Placement on a level surface free of obstructions (including snow, for winter operation) or air recirculation ensures rated performance, reliable operation and ease of maintenance. Site restrictions may compromise minimum clearances indicated below, resulting in unpredictable air patterns and possible diminished performance. York's unit controls will optimize operation without nuisance high pressure safety cutout; however, the system designer must consider potential performance degradation. Access to the unit control center assumes the unit is no higher than on spring isolators. Recommended minimum clearances: side to wall - 2m; rear to wall - 2m; control panel end to wall - 1.2m; top - no obstructions allowed; distance between adjacent units - 3m. No more than one adjacent wall may be higher than the unit.

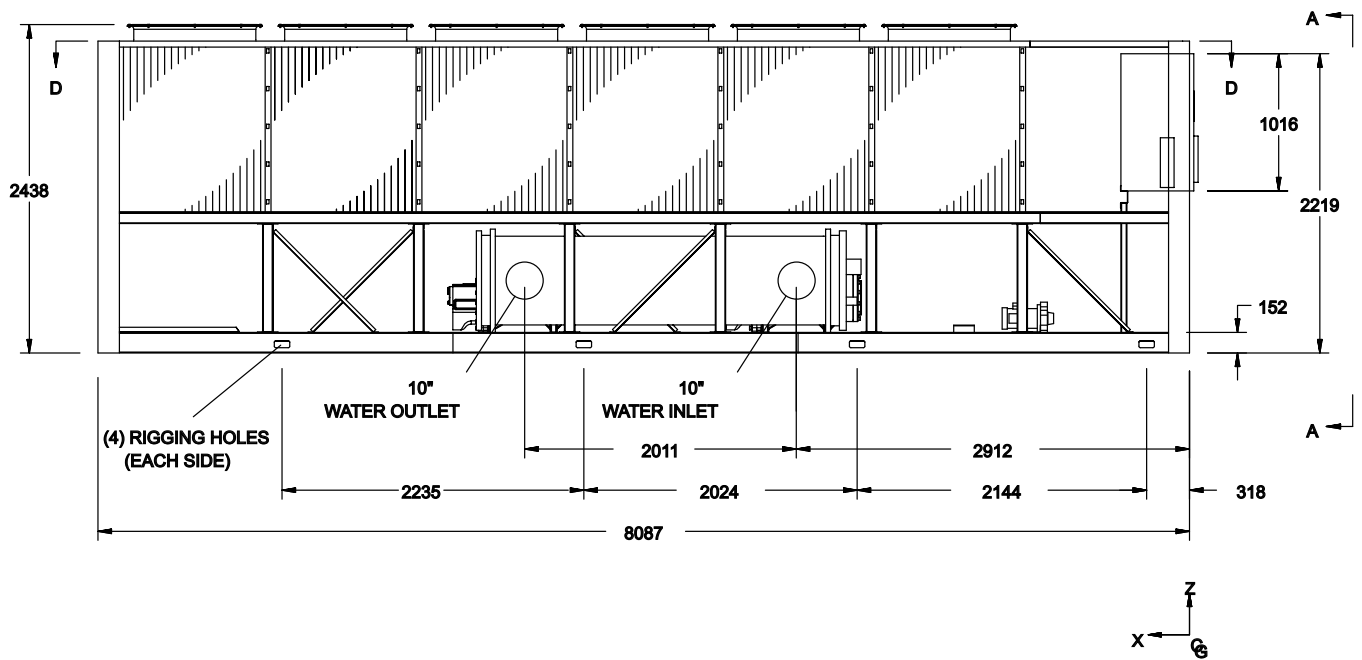
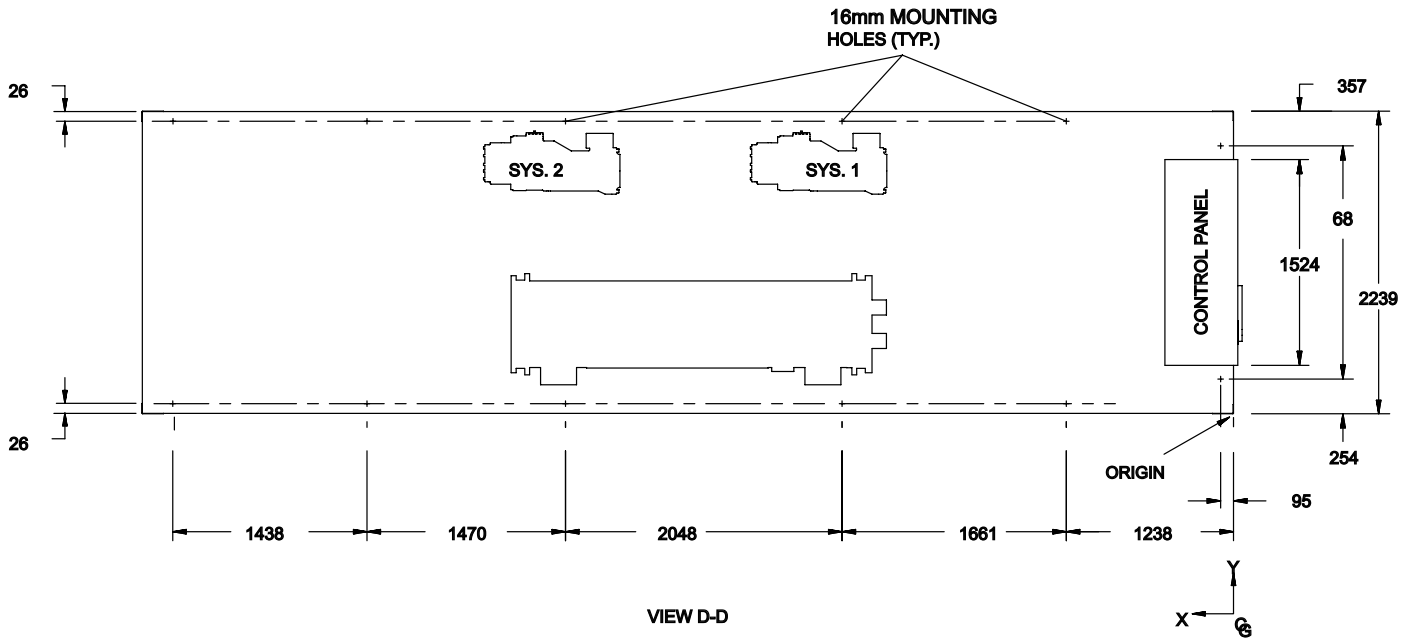

Dimensions – SI

YCAV0267E/V, 0287S/P

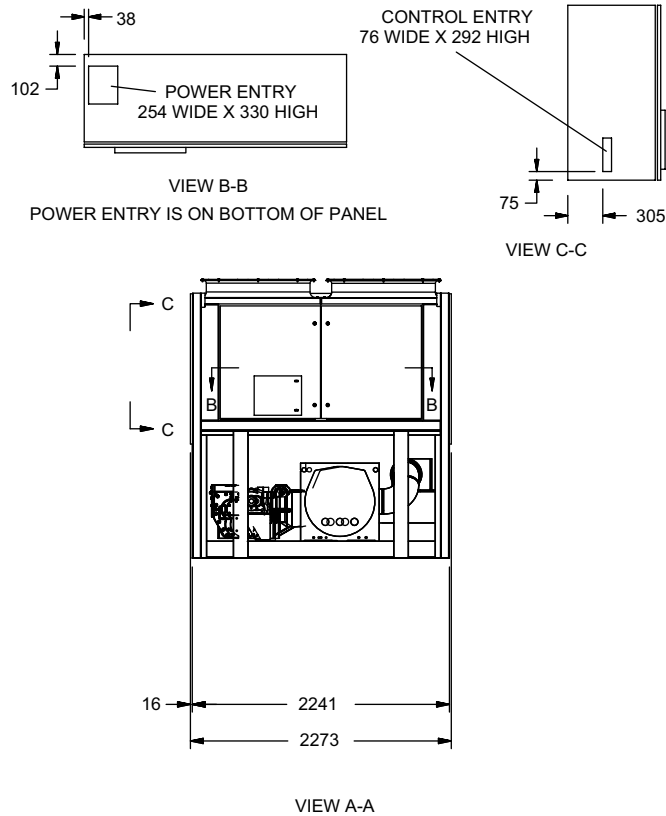

Notes:
1. Placement on a level surface free of obstructions (including snow, for winter operation) or air recirculation ensures rated performance, reliable operation and ease of maintenance. Site restrictions may compromise minimum clearances indicated below, resulting in unpredictable air patterns and possible diminished performance. York's unit controls will optimize operation without nuisance high pressure safety cutout; however, the system designer must consider potential performance degradation. Access to the unit control center assumes the unit is no higher than on spring isolators. Recommended minimum clearances: side to wall - 2m; rear to wall - 2m; control panel end to wall - 1.2m; top - no obstructions allowed; distance between adjacent units - 3m. No more than one adjacent wall may be higher than the unit.

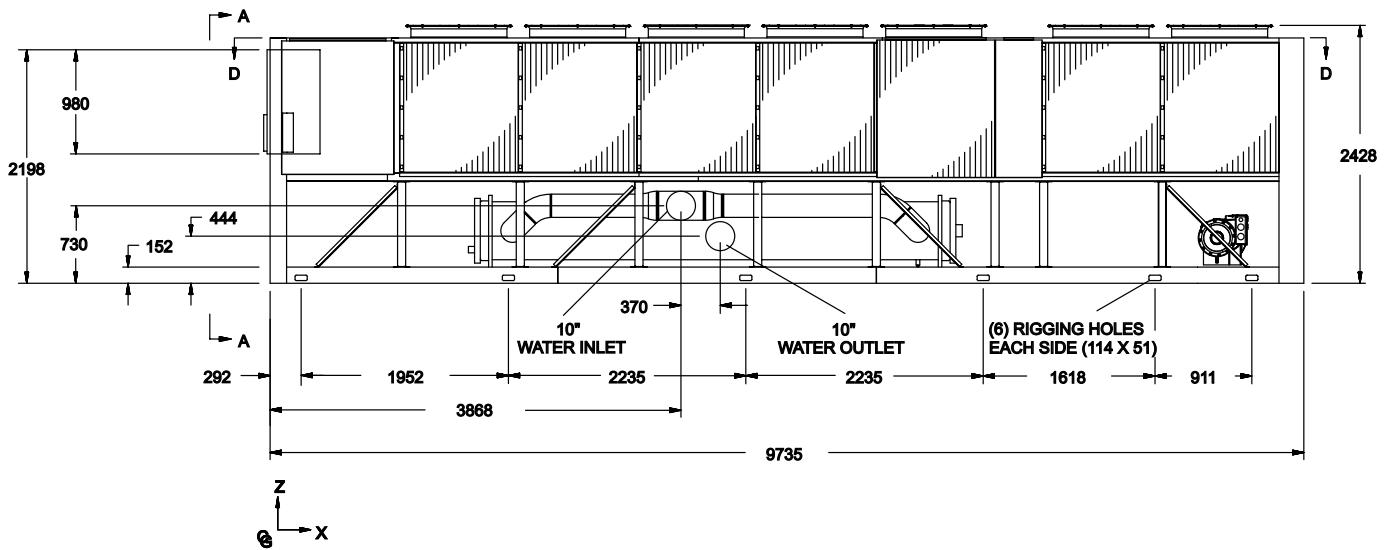
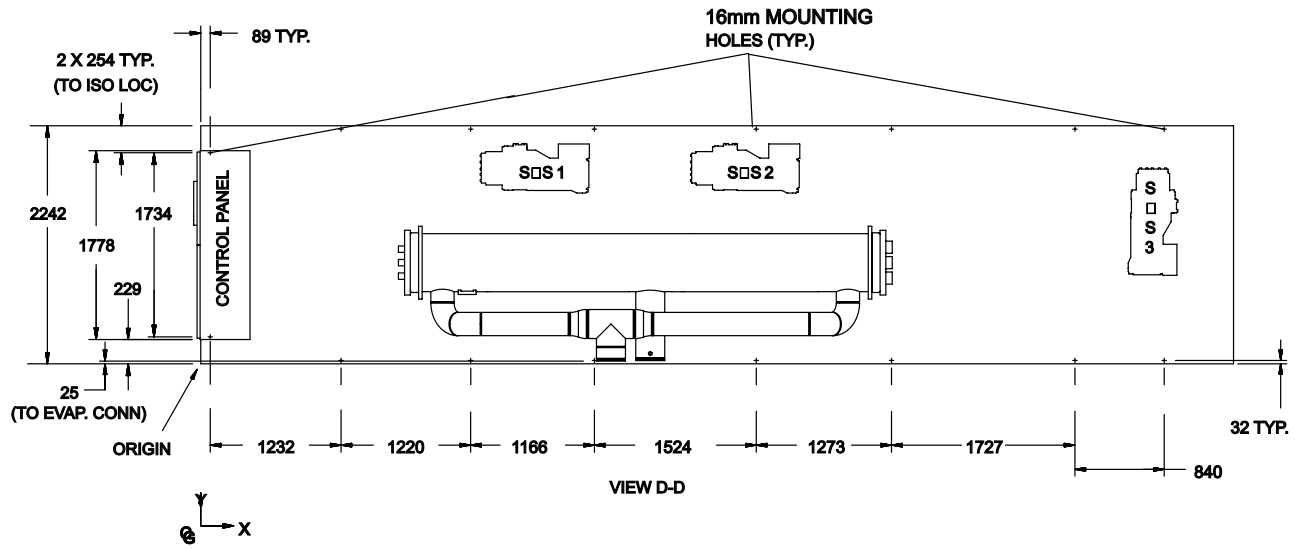

Dimensions – SI

YCAV0287E/V

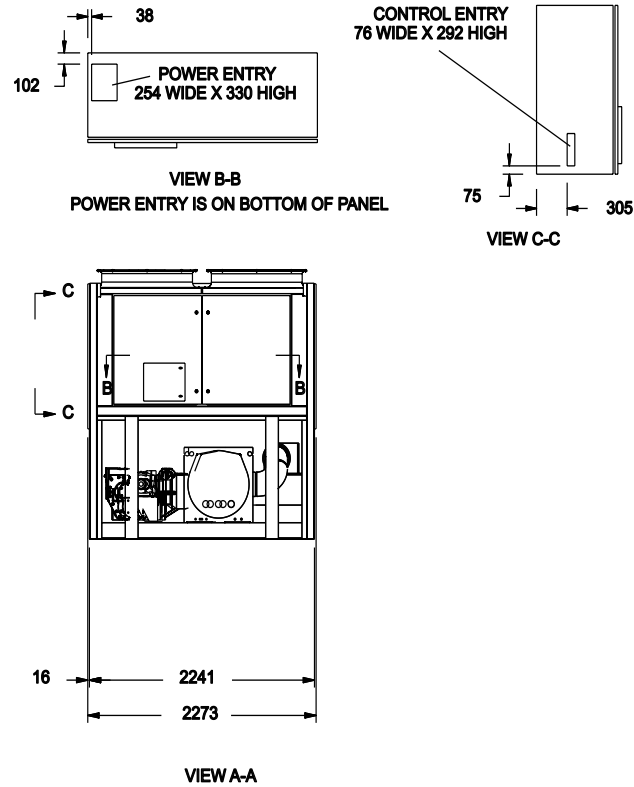

POWER: SINGLE POINT WITH TERMINAL BLOCK

Notes:
1. Placement on a level surface free of obstructions (including snow, for winter operation) or air recirculation ensures rated performance, reliable operation and ease of maintenance. Site restrictions may compromise minimum clearances indicated below, resulting in unpredictable air patterns and possible diminished performance. York's unit controls will optimize operation without nuisance high pressure safety cutout; however, the system designer must consider potential performance degradation. Access to the unit control center assumes the unit is no higher than on spring isolators. Recommended minimum clearances: side to wall - 2m; rear to wall - 2m; control panel end to wall - 1.2m; top - no obstructions allowed; distance between adjacent units - 3m. No more than one adjacent wall may be higher than the unit.

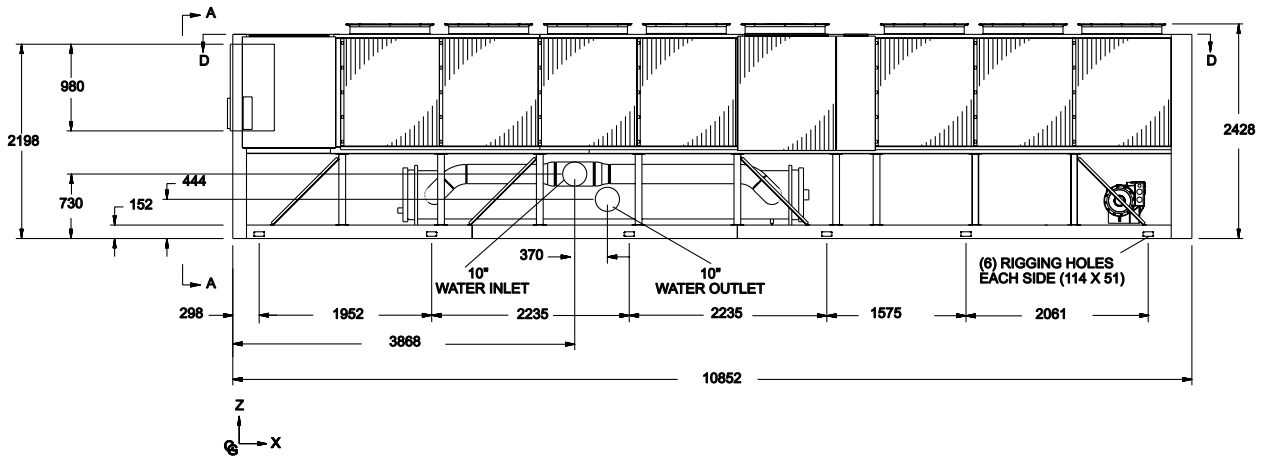
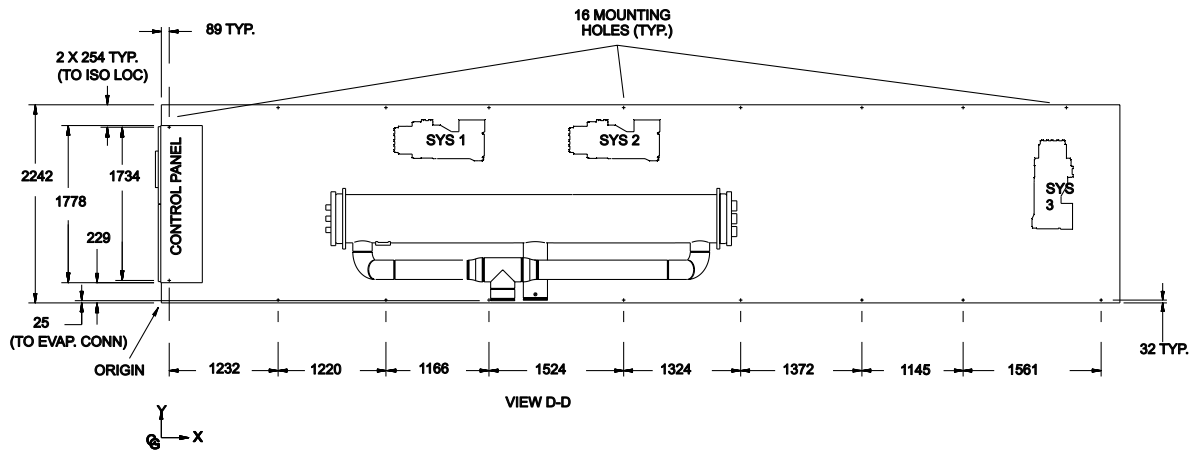

Dimensions – SI

YCAV0307S/P

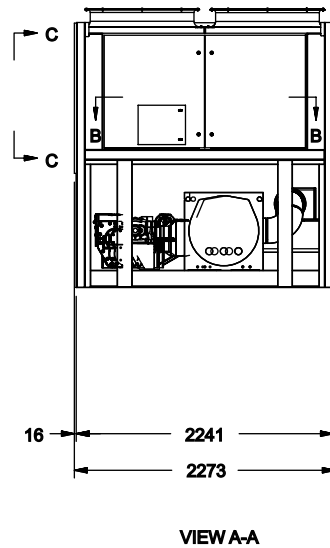
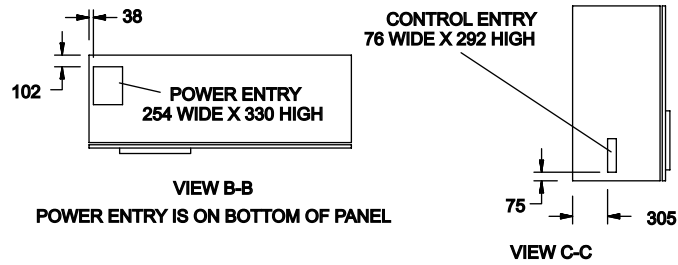

Notes:
1. Placement on a level surface free of obstructions (including snow, for winter operation) or air recirculation ensures rated performance, reliable operation and ease of maintenance. Site restrictions may compromise minimum clearances indicated below, resulting in unpredictable air patterns and possible diminished performance. York's unit controls will optimize operation without nuisance high pressure safety cutout; however, the system designer must consider potential performance degradation. Access to the unit control center assumes the unit is no higher than on spring isolators. Recommended minimum clearances: side to wall - 2m; rear to wall - 2m; control panel end to wall - 1.2m; top - no obstructions allowed; distance between adjacent units - 3m. No more than one adjacent wall may be higher than the unit.

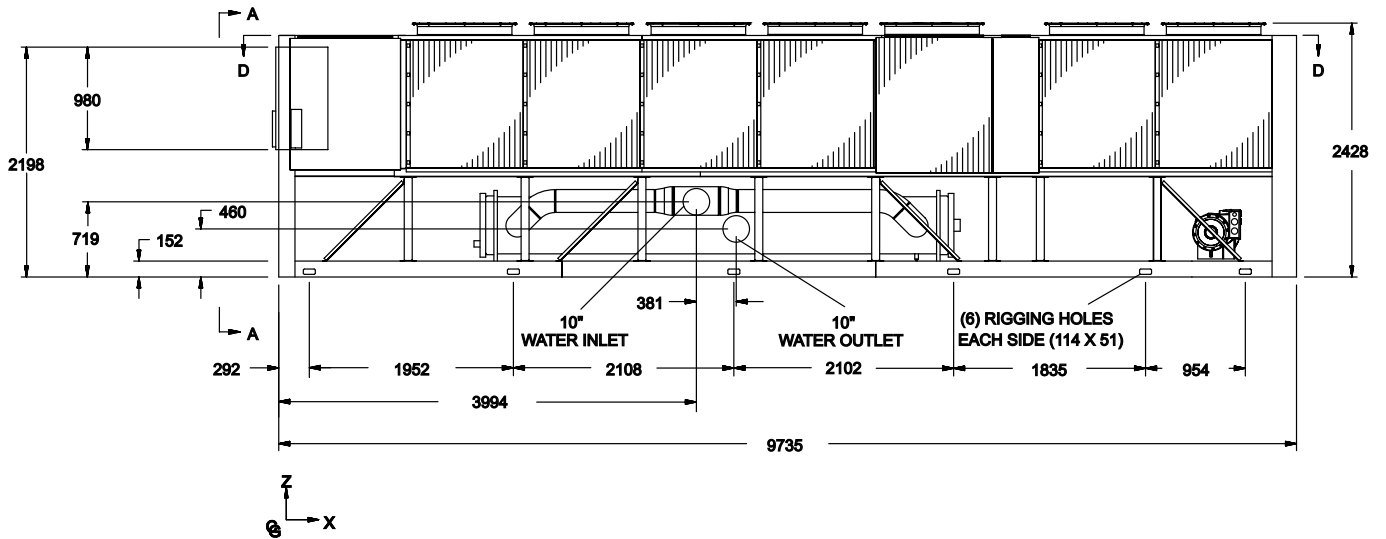
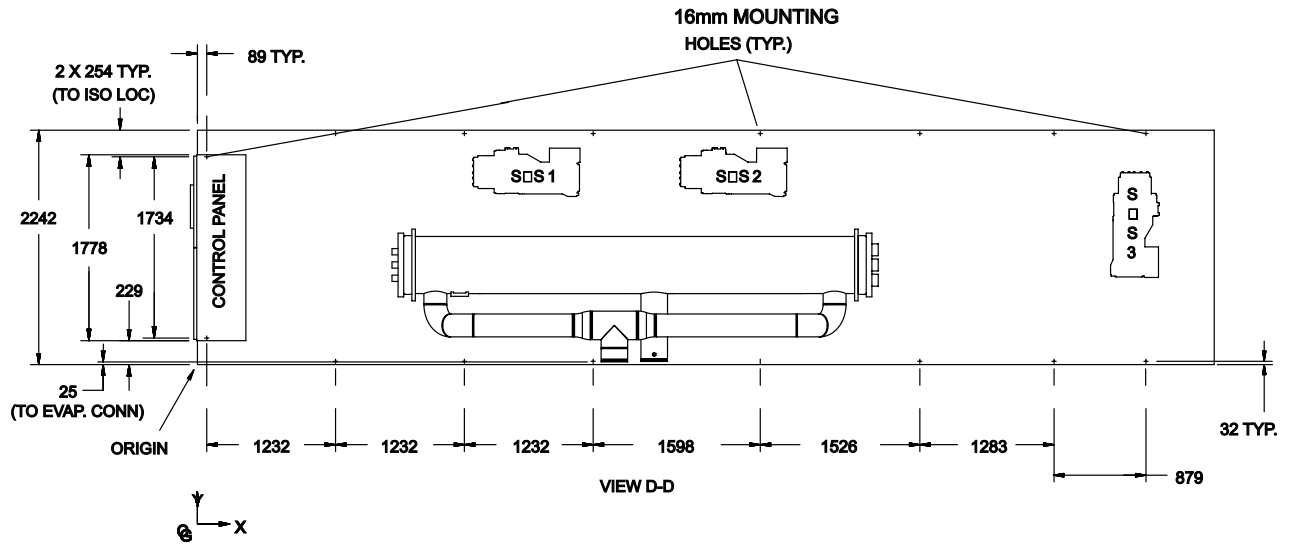

Dimensions – SI

YCAV0327E/V, 0357S/P

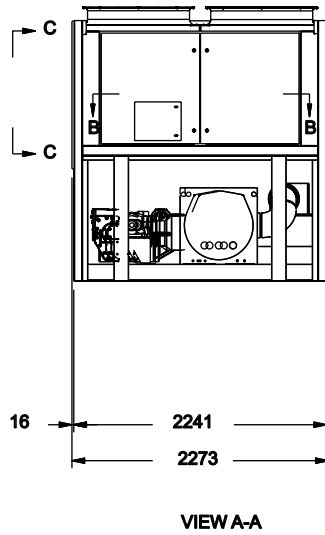
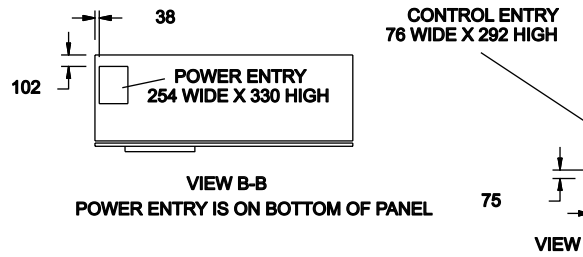

Notes:

1. Placement on a level surface free of obstructions (including snow, for winter operation) or air recirculation ensures rated performance, reliable operation and ease of maintenance. Site restrictions may compromise minimum clearances indicated below, resulting in unpredictable air patterns and possible diminished performance. York's unit controls will optimize operation without nuisance high pressure safety cutout; however, the system designer must consider potential performance degradation. Access to the unit control center assumes the unit is no higher than on spring isolators. Recommended minimum clearances: side to wall - 2m; rear to wall - 2m; control panel end to wall - 1.2m; top - no obstructions allowed; distance between adjacent units - 3m. No more than one adjacent wall may be higher than the unit.

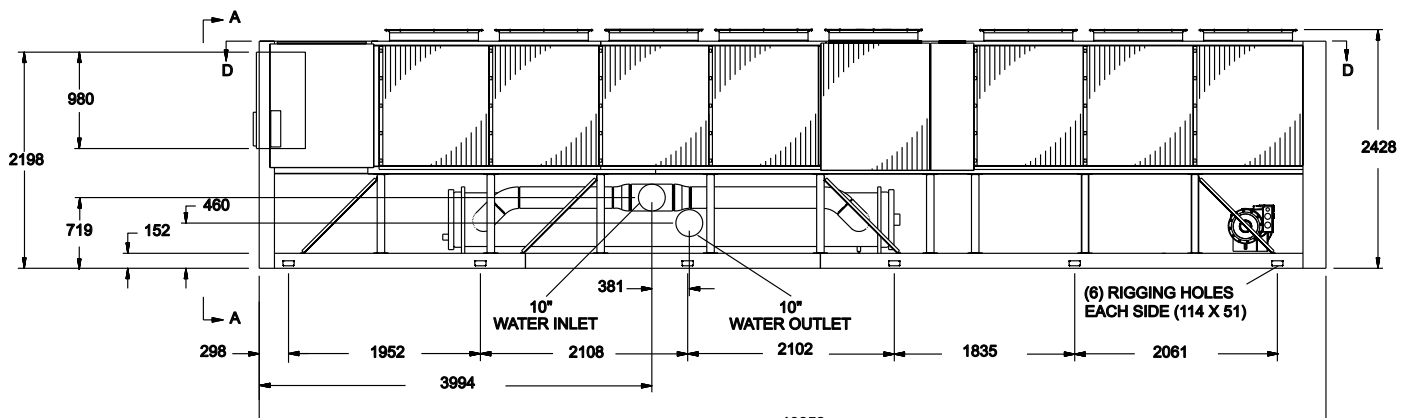
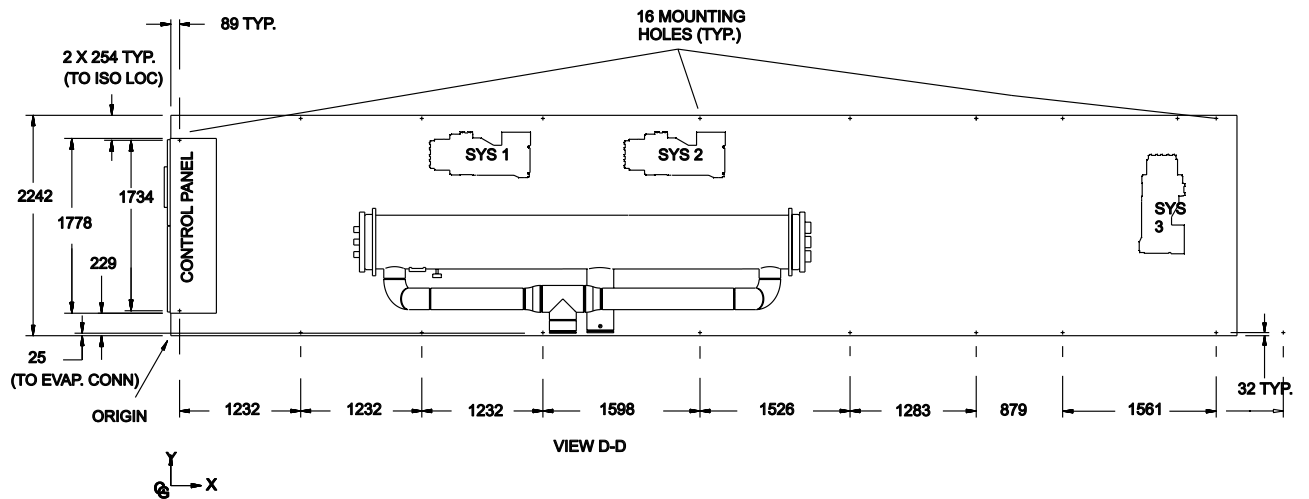

Dimensions – SI

YCAV0357E/V, 0397S/V

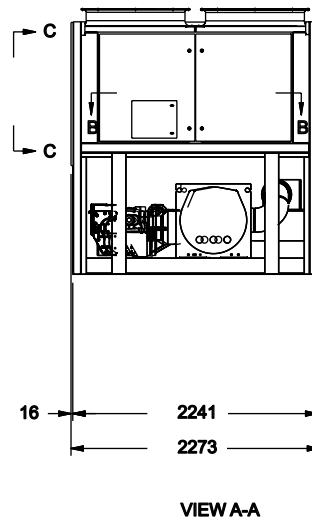
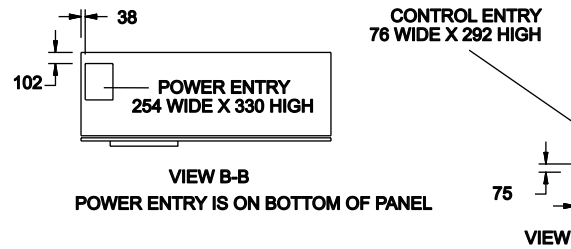

POWER: SINGLE POINT WITH TERMINAL BLOCK

Notes:
1. Placement on a level surface free of obstructions (including snow, for winter operation) or air recirculation ensures rated performance, reliable operation and ease of maintenance. Site restrictions may compromise minimum clearances indicated below, resulting in unpredictable air patterns and possible diminished performance. York's unit controls will optimize operation without nuisance high pressure safety cutout; however, the system designer must consider potential performance degradation. Access to the unit control center assumes the unit is no higher than on spring isolators. Recommended minimum clearances: side to wall - 2m; rear to wall - 2m; control panel end to wall - 1.2m; top - no obstructions allowed; distance between adjacent units - 3m. No more than one adjacent wall may be higher than the unit.

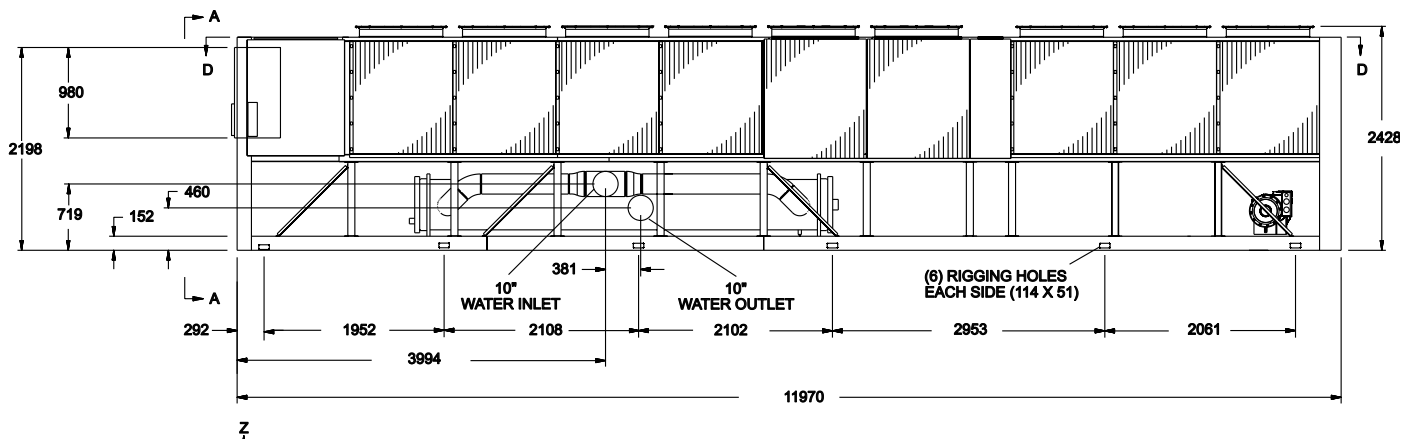
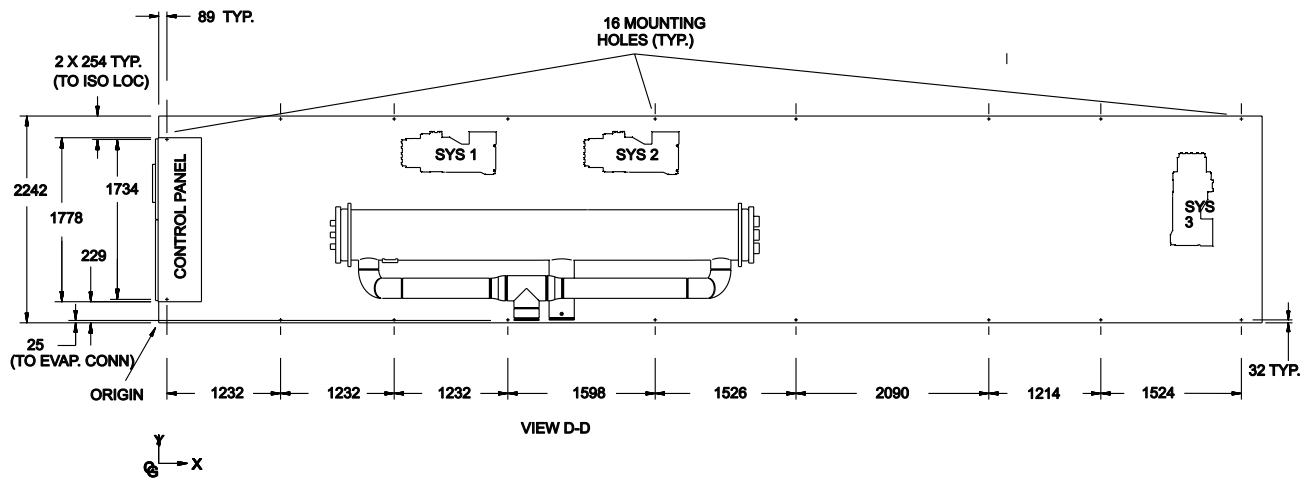

Dimensions – SI

YCAV0397E/V, 0417S/P, 1429E/V, 1549S/P

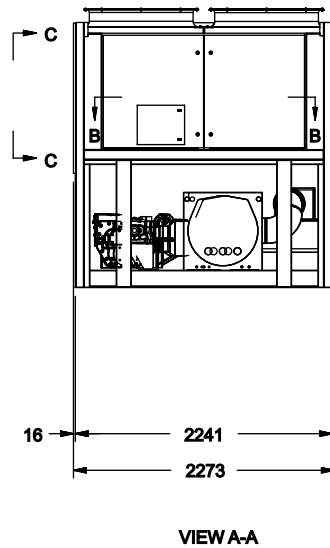
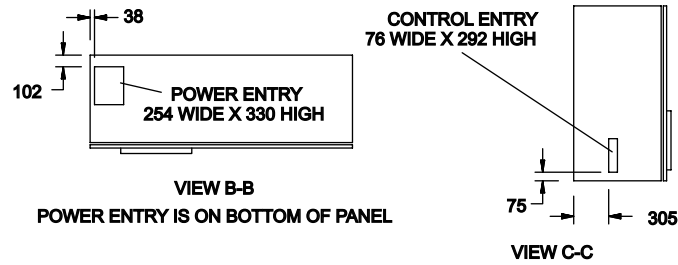

Notes:

1. Placement on a level surface free of obstructions (including snow, for winter operation) or air recirculation ensures rated performance, reliable operation and ease of maintenance. Site restrictions may compromise minimum clearances indicated below, resulting in unpredictable air patterns and possible diminished performance. York's unit controls will optimize operation without nuisance high pressure safety cutout; however, the system designer must consider potential performance degradation. Access to the unit control center assumes the unit is no higher than on spring isolators. Recommended minimum clearances: side to wall - 2m; rear to wall - 2m; control panel end to wall - 1.2m; top - no obstructions allowed; distance between adjacent units - 3m. No more than one adjacent wall may be higher than the unit.

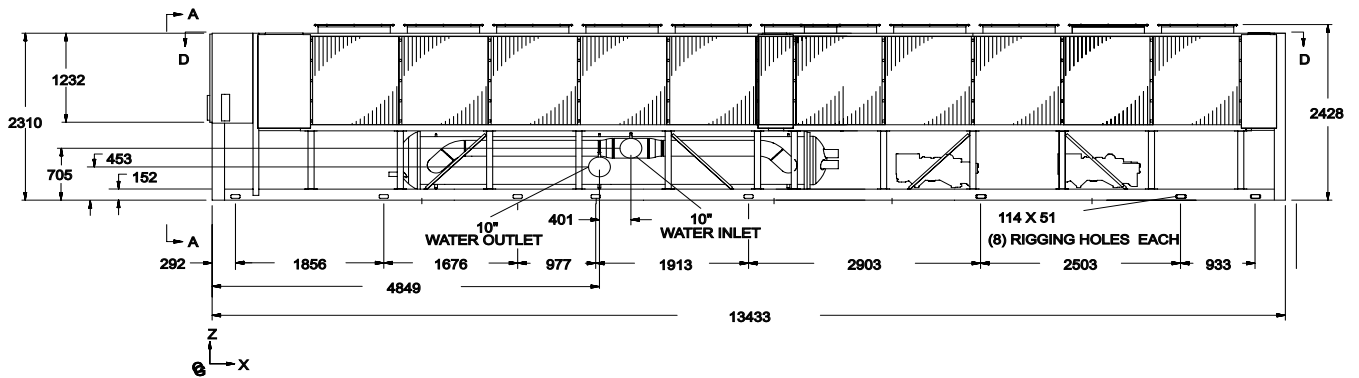
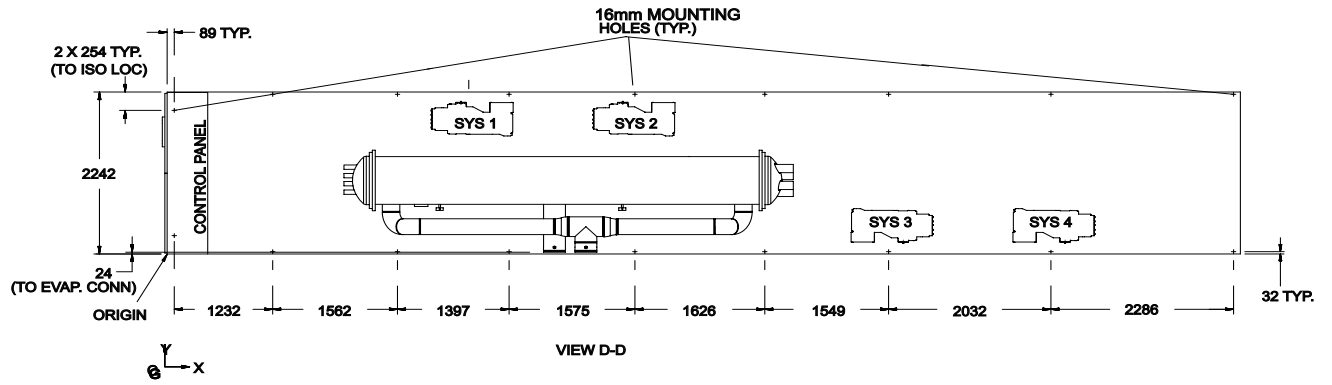

Dimensions – SI

YCAV0417E/V, 0477S/P, 1549E/V, 1739S/P

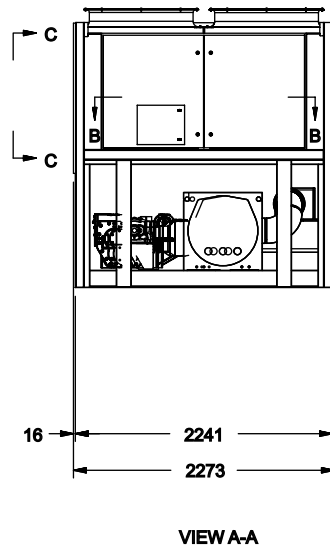
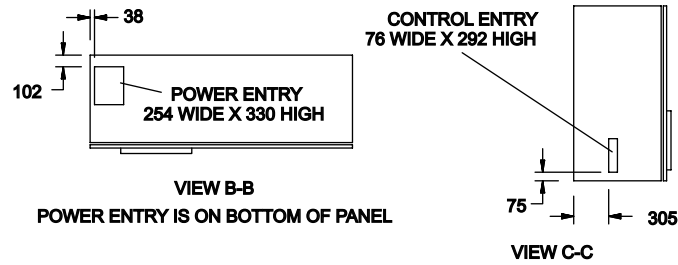

Notes:

1. Placement on a level surface free of obstructions (including snow, for winter operation) or air recirculation ensures rated performance, reliable operation and ease of maintenance. Site restrictions may compromise minimum clearances indicated below, resulting in unpredictable air patterns and possible diminished performance. York's unit controls will optimize operation without nuisance high pressure safety cutout; however, the system designer must consider potential performance degradation. Access to the unit control center assumes the unit is no higher than on spring isolators. Recommended minimum clearances: side to wall - 2m; rear to wall - 2m; control panel end to wall - 1.2m; top - no obstructions allowed; distance between adjacent units - 3m. No more than one adjacent wall may be higher than the unit.

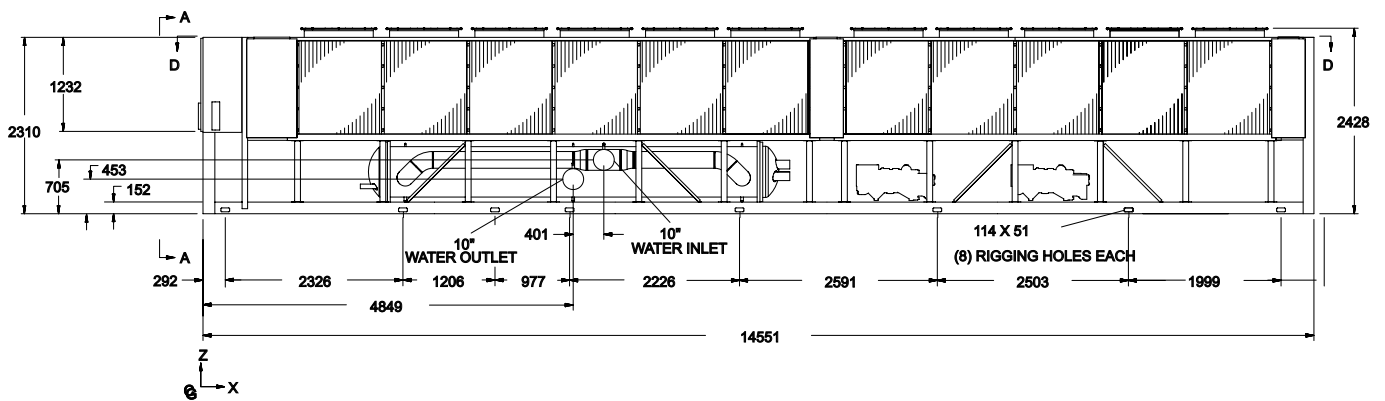
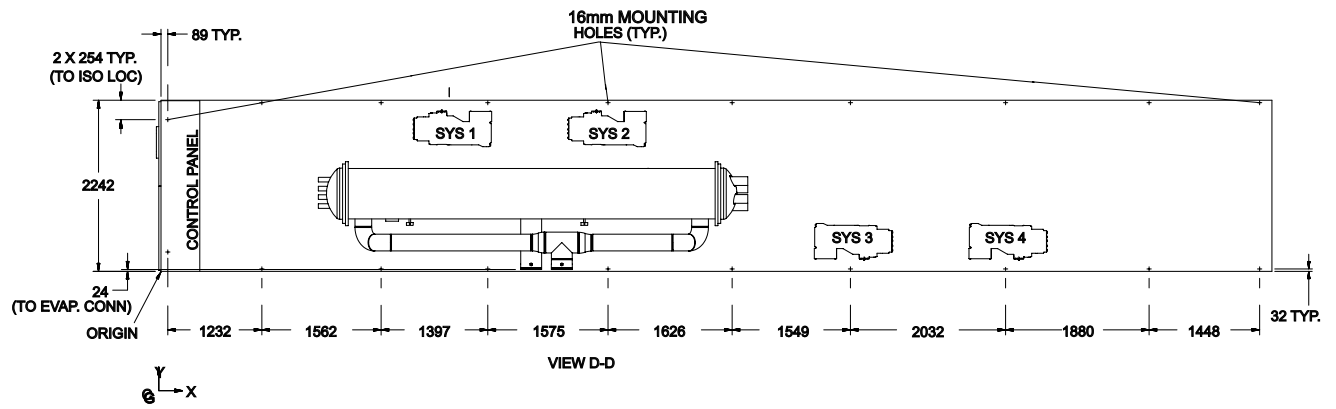

Dimensions – SI

YCAV0457S/P, 1649S/P

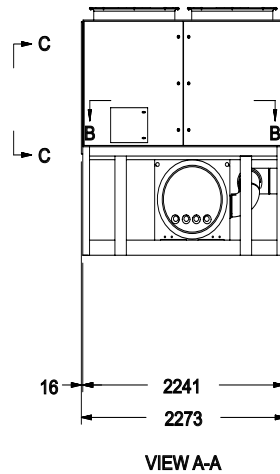
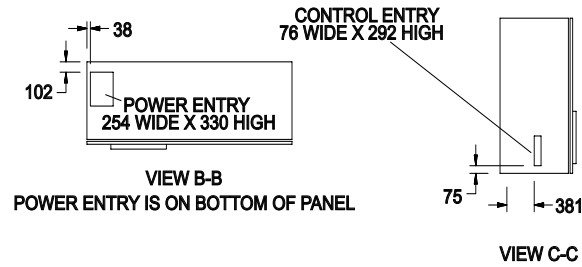

Notes:
1. Placement on a level surface free of obstructions (including snow, for winter operation) or air recirculation ensures rated performance, reliable operation and ease of maintenance. Site restrictions may compromise minimum clearances indicated below, resulting in unpredictable air patterns and possible diminished performance. York's unit controls will optimize operation without nuisance high pressure safety cutout; however, the system designer must consider potential performance degradation. Access to the unit control center assumes the unit is no higher than on spring isolators. Recommended minimum clearances: side to wall - 2m; rear to wall - 2m; control panel end to wall - 1.2m; top - no obstructions allowed; distance between adjacent units - 3m. No more than one adjacent wall may be higher than the unit.

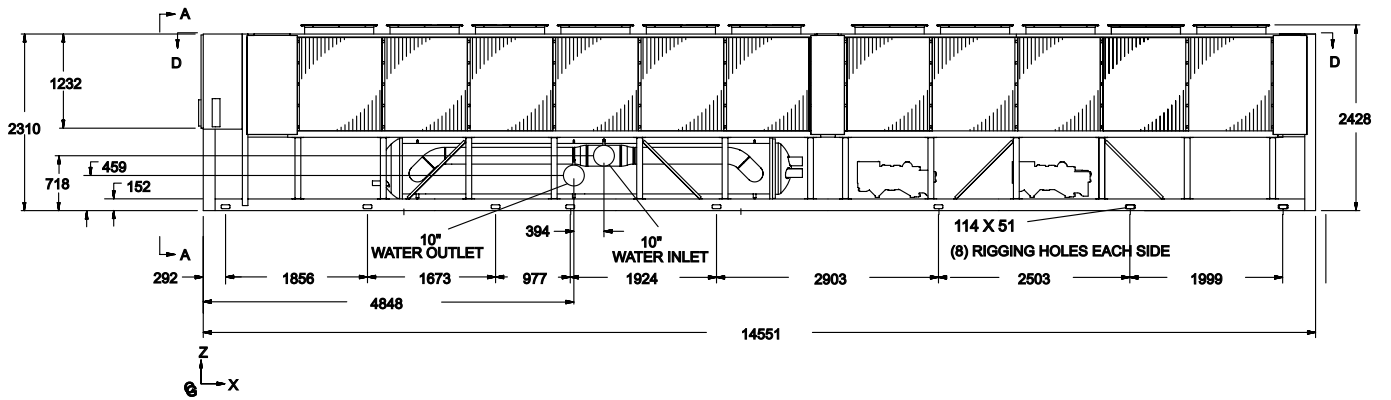
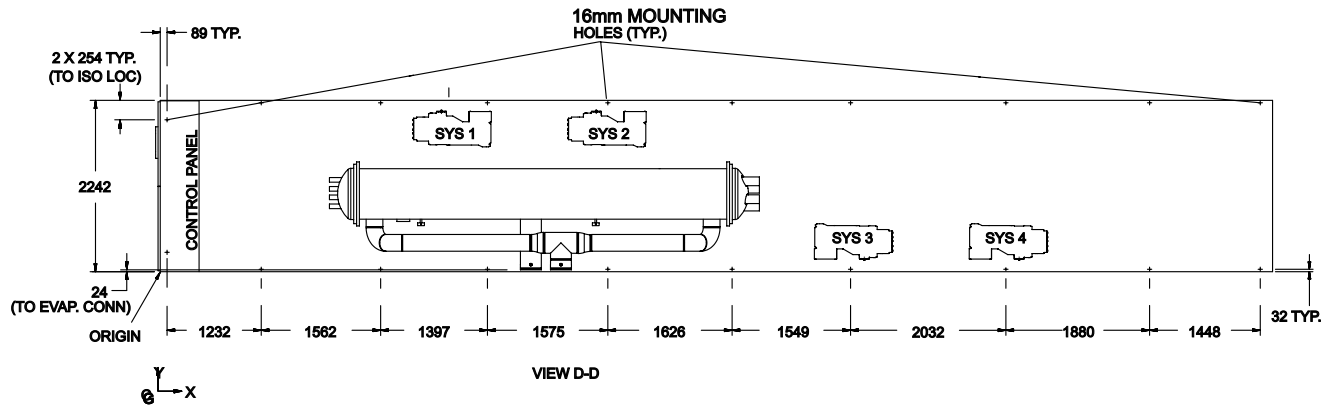

Dimensions – SI

YCAV0477E/V, 0507S/P, 0527S/P, 1739E/V, 1829S/P, 1909S/P

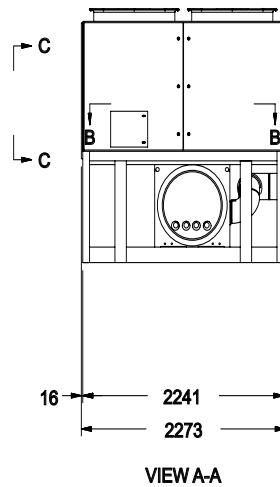
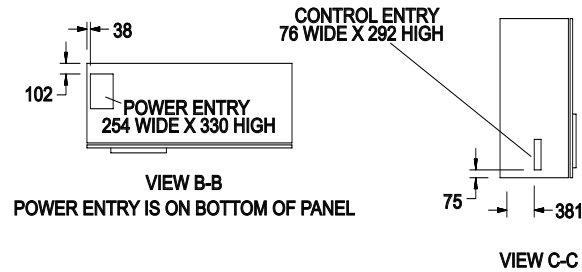

Notes:
1. Placement on a level surface free of obstructions (including snow, for winter operation) or air recirculation ensures rated performance, reliable operation and ease of maintenance. Site restrictions may compromise minimum clearances indicated below, resulting in unpredictable air patterns and possible diminished performance. York's unit controls will optimize operation without nuisance high pressure safety cutout; however, the system designer must consider potential performance degradation. Access to the unit control center assumes the unit is no higher than on spring isolators. Recommended minimum clearances: side to wall - 2m; rear to wall - 2m; control panel end to wall - 1.2m; top - no obstructions allowed; distance between adjacent units - 3m. No more than one adjacent wall may be higher than the unit.

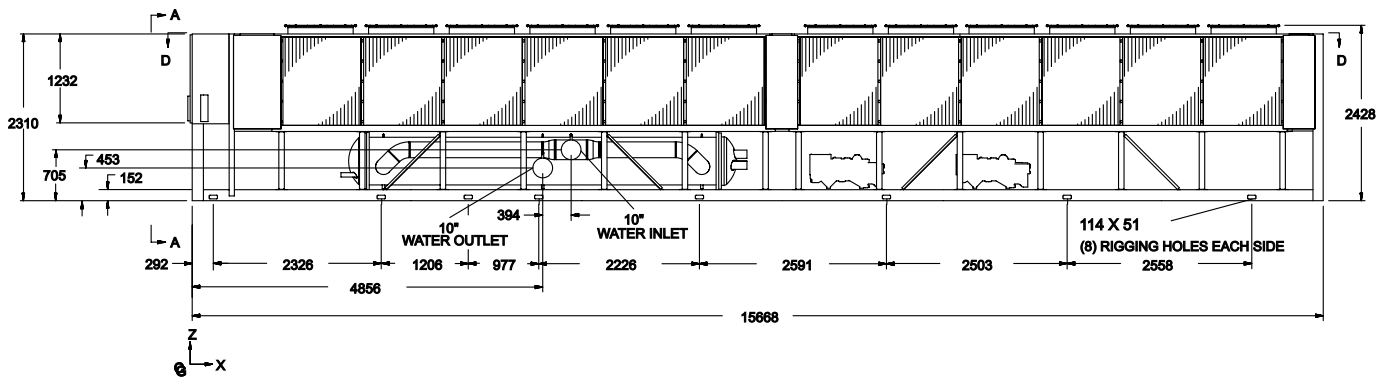
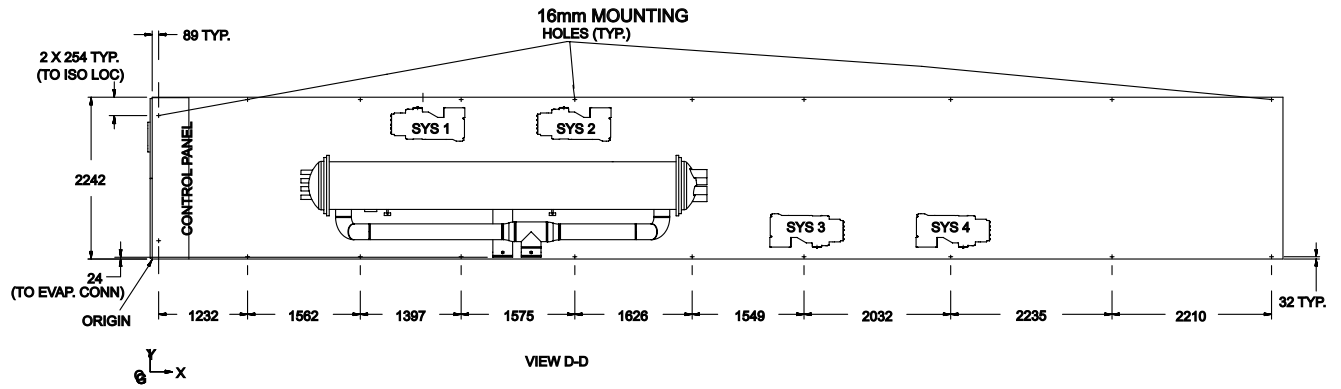

Isolator Details

ONE INCH DEFLECTION SPRING ISOLATOR CROSS-REFERENCE

CIP-X-

Illustration shows single spring CIP-B or CIP-C mount.

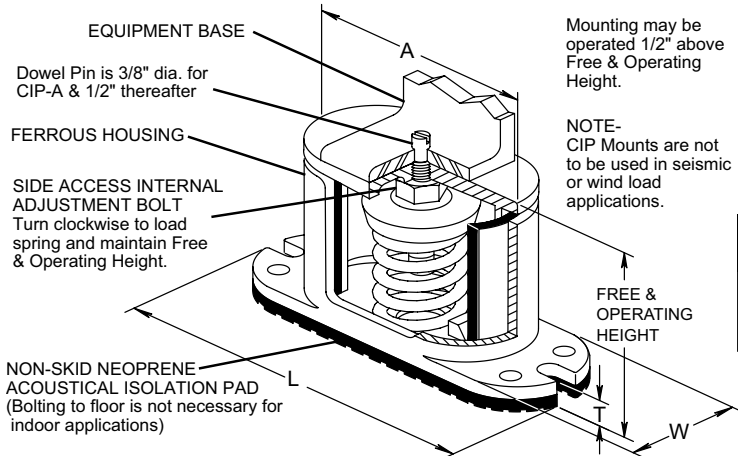

TYPE CIP DIMENSIONS (inches)†

Size	A	L	T	W	SW	HCL	HCW	MBD	SBC	Free Ht.	Min Ht.
CIP-B	5 ³ / ₄	8 ¹ / ₄	1/2	2 ³ / ₄	7/16	6 ¹ / ₂	1 ¹ / ₂	3/8	7 ¹ / ₄	6 ¹ / ₈	5 ¹ / ₄
CIP-C	6 ⁵ / ₈	8 ⁷ / ₈	9/16	3 ¹ / ₂	7/16	7 ¹ / ₄	1 ³ / ₄	3/8	7 ⁷ / ₈	6 ³ / ₄	6 ³ / ₄

†Casting dimensions may vary ±1/8"

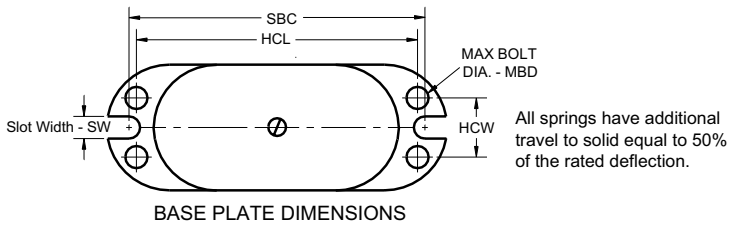

FOR UNITS WITH ALL POINT LOADS LESS THAN 1404 LBS (637 KG)

Weight Range (lbs)	Weight Range (kg)	Model Number	Color
239 to 384 lbs	108 to 174 kg	CIP-B-	Red
384 to 639 lbs	174 to 290 kg	CIP-B-	White
639 to 851 lbs	290 to 386 kg	CIP-B-	Blue
851 to 1064 lbs	386 to 483 kg	CIP-B-	Gray
1064 to 1404 lbs	483 to 637 kg	CIP-B-	Black

FOR UNITS WITH ANY POINT LOAD ABOVE 1404 LBS (637 KG)

Weight Range (lbs)	Weight Range (kg)	Model Number	Color
Up to 851 lbs	Up to 386 kg	CIP-C-	Black
851 to 1149 lbs	386 to 521 kg	CIP-C-	Yellow
1149 to 1489 lbs	521 to 675 kg	CIP-C-	Black
1489 to 1786 lbs	675 to 910 kg	CIP-C-	Yellow w/ Red
1786 to 2028 lbs	910 to 920 kg	CIP-C-	Yellow w/ Green
2028 to 2254 lbs	920 to 1022 kg	CIP-C-	Red w/ Red
2254 to 2936 lbs	1022 to 1332 kg	CIP-C-	Red w/ Green

NEOPRENE ISOLATOR CROSS-REFERENCE

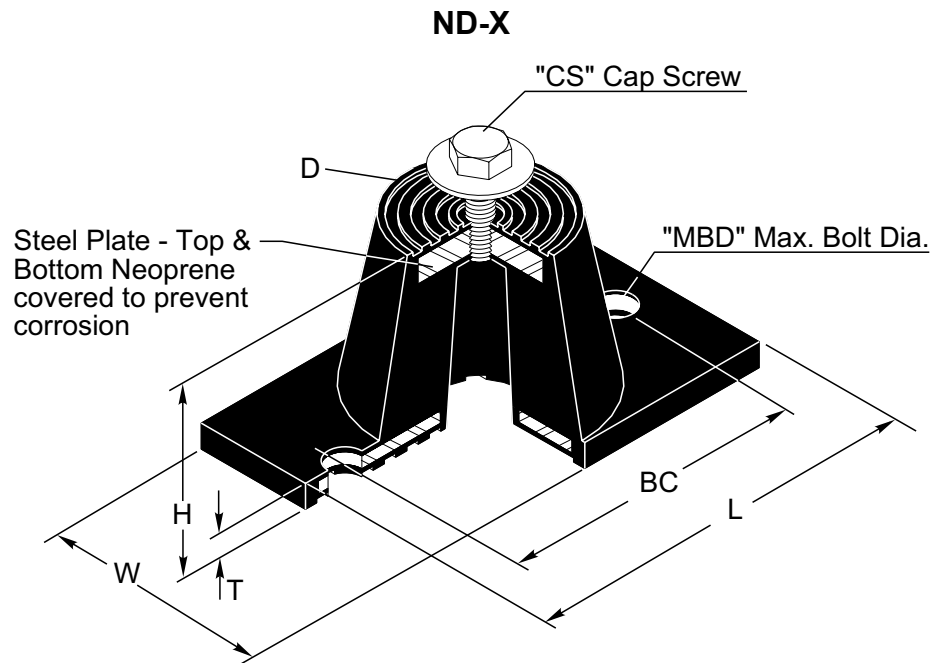

ENGLISH								
Size	D	H	L	T	W	BC	CS	MBD
ND-C	2 9/16	2 3/4	5 1/2	1/4	2 5/16	4 1/80	1/2- 13 x 1"	1/2"
ND-D	3 3/8	2 3/4	6 1/4	5/16	4	5	1/2- 13 x 1"	1/2"
ND-E	4 1/2	4 3/4	7 3/8	1/4	5 1/80	6 1/80	1/2- 13 x 1"	1/2"
SI								
ND-C	65.1	69.9	139.7	6.4	58.7	101.9	1/2- 13 x 1"	1/2"
ND-D	85.7	69.9	158.8	7.9	101.6	127.0	1/2- 13 x 1"	1/2"
ND-E	114.3	120.7	187.3	6.4	127.3	152.7	1/2- 13 x 1"	1/2"

Weight Range (lbs)	Weight Range (kg)	Model Number	Color
Up to 751 lbs	Up to 341 kg	ND-C	Yellow
751 to 1651 lbs	341 to 749 kg	ND-D	Yellow
1651 to 3226 lbs	749 to 1463 kg	ND-DS	Yellow

Isolator Details - continued

TWO INCH DEFLECTION, SEISMIC SPRING ISOLATOR CROSS-REFERENCE

SLRS

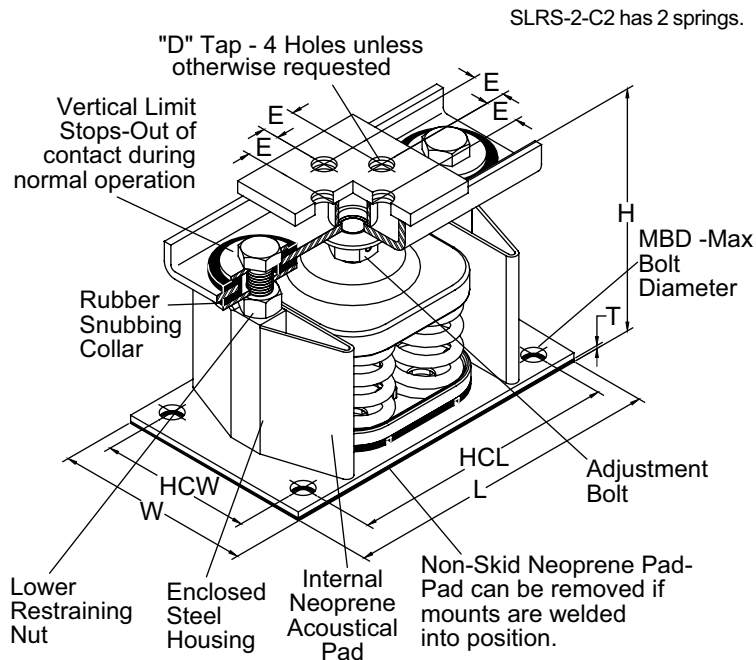

ENGLISH

SIZE	H	T	D	E	L	HCL	W	HCW	MBD
2-C2	8 1/2	3/8	5/8	1 3/8	14	12 1/4	5 1/4	3 1/2	5/8"

SI

SIZE	H	T	D	E	L	HCL	W	HCW	MBD
2-C2	215.9	9.5	15.9	34.9	355.6	311.2	133.4	88.9	5/8"

*Weight Range (lbs)	Weight Range (kg)	Model Number	Color
Up to 358 lbs	Up to 162 kg	SLRS-2-C2-	Red
358 to 443 lbs	162 to 201 kg	SLRS-2-C2-	White
443 to 582 lbs	201 to 264 kg	SLRS-2-C2-	Black
582 to 783 lbs	264 to 335 kg	SLRS-2-C2-	Blue
783 to 1038 lbs	335 to 471 kg	SLRS-2-C2-	Green
1038 to 1497 lbs	471 to 679 kg	SLRS-2-C2-	Gray
1497 to 2058 lbs	679 to 933 kg	SLRS-2-C2-	Silver
2058 to 2619 lbs	933 to 1188 kg	SLRS-2-C2-	Gray w/ red
2619 to 3180 lbs	1188 to 1442 kg	SLRS-2-C2-	Silver w/ red

INTENTIONALLY LEFT BLANK

Electrical Data - 2 Comp - 60Hz

STANDARD EFFICIENCY UNITS (SEE FIG. 1)

Model Number /Nameplate			System 1			System 2			Control KVA ⁸	Unit Short Circuit Withstand (KA)	
			Compressor RLA ⁶	Cond. Fans		Compressor RLA ⁶	Cond. Fans			Terminal Block (STD)	Circuit Breaker (OPT)
YCAV S/P	Input Volts	Input Freq		Qty.	FLA (EA)		Qty.	FLA (EA)			
0157	200	60	278	4	6.5	278	4	6.5	1.8	30KA	100KA
	230	60	241	4	5.6	241	4	5.6	1.8	30KA	100KA
	575	60	96	4	2.2	96	4	2.2	1.8	30KA	42KA
0177	200	60	368	4	6.5	244	4	6.5	1.8	30KA	100KA
	230	60	319	4	5.6	211	4	5.6	1.8	30KA	100KA
	575	60	127	4	2.2	84	4	2.2	1.8	30KA	42KA
0187	200	60	376	5	6.5	278	4	6.5	1.8	30KA	100KA
	230	60	325	5	5.6	241	4	5.6	1.8	30KA	100KA
	575	60	130	5	2.2	96	4	2.2	1.8	30KA	42KA
0207	200	60	336	5	6.5	379	4	6.5	1.8	30KA	100KA
	230	60	291	5	5.6	328	4	5.6	1.8	30KA	100KA
	575	60	116	5	2.2	131	4	2.2	1.8	30KA	42KA
0227	200	60	375	5	6.5	375	5	6.5	1.8	30KA	100KA
	230	60	325	5	5.6	325	5	5.6	1.8	30KA	100KA
	575	60	130	5	2.2	130	5	2.2	1.8	30KA	42KA
0247	200	60	448	6	6.5	371	5	6.5	1.8	30KA	100KA
	230	60	388	6	5.6	321	5	5.6	1.8	30KA	100KA
	575	60	155	6	2.2	128	5	2.2	1.8	30KA	42KA
0267	200	60	444	6	6.5	444	6	6.5	1.8	30KA	100KA
	230	60	385	6	5.6	385	6	5.6	1.8	30KA	100KA
	575	60	154	6	2.2	154	6	2.2	1.8	30KA	42KA

See page 142 for Electrical Data footnotes.

STANDARD EFFICIENCY UNITS (SEE FIG. 1)

YCAV S/P	Field Wiring & Protection				Field Wiring Lugs STD Terminal Block		Field Wiring Lugs OPT Circuit Breaker	
	Minimum Ckt. Ampacity (MCA) ⁴	Recommended Fuse/ Ckt. Breaker Rating ⁵	Max. Inverse Time Ckt. Brkr. Rating ²	Max Dual Element Fuse Size ³	Lugs/ Phase ¹	Lug Wire Range	Lugs/Phase ₁	Lug Wire Range
0157	677	800	1600	1200	4	2AWG - 600 kcmil	4	4/0AWG - 500 kcmil
	587	700	1600	1000	4	2AWG - 600 kcmil	4	4/0AWG - 500 kcmil
	234	300	600	400	2	2AWG - 600 kcmil	2	2/0AWG - 500 kcmil
0177	755	1000	2000	1200	4	2AWG - 600 kcmil	4	4/0AWG - 500 kcmil
	654	800	1600	1200	4	2AWG - 600 kcmil	4	4/0AWG - 500 kcmil
	261	300	600	450	2	2AWG - 600 kcmil	2	2/0AWG - 500 kcmil
0187	805	1000	2000	1600	4	2AWG - 600 kcmil	4	4/0AWG - 500 kcmil
	698	800	1600	1200	4	2AWG - 600 kcmil	4	4/0AWG - 500 kcmil
	279	350	700	450	2	2AWG - 600 kcmil	2	2/0AWG - 500 kcmil
0207	857	1000	2000	1600	4	2AWG - 600 kcmil	4	4/0AWG - 500 kcmil
	742	1000	2000	1200	4	2AWG - 600 kcmil	4	4/0AWG - 500 kcmil
	296	350	700	500	2	2AWG - 600 kcmil	2	2/0AWG - 500 kcmil
0227	908	1200	2000	1600	4	2AWG - 600 kcmil	4	4/0AWG - 500 kcmil
	786	1000	2000	1600	4	2AWG - 600 kcmil	4	4/0AWG - 500 kcmil
	314	350	800	500	2	2AWG - 600 kcmil	2	2/0AWG - 500 kcmil
0247	1002	1200	2000	1600	4	2AWG - 600 kcmil	4	4/0AWG - 500 kcmil
	868	1000	2000	1600	4	2AWG - 600 kcmil	4	4/0AWG - 500 kcmil
	347	400	800	600	2	2AWG - 600 kcmil	2	2/0AWG - 500 kcmil
0267	1076	1200	2000	2000	4	2AWG - 600 kcmil	4	4/0AWG - 500 kcmil
	932	1200	2000	1600	4	2AWG - 600 kcmil	4	4/0AWG - 500 kcmil
	372	450	1000	600	2	2AWG - 600 kcmil	2	2/0AWG - 500 kcmil

Electrical Data - 2 Comp - 60Hz

HIGH EFFICIENCY UNITS

Model Number /Nameplate			System 1			System 2			Control KVA ⁸	Unit Short Circuit Withstand (KA)	
YCAV E/V	Input Volts	Input Freq	Compressor RLA ⁶	Cond. Fans		Compressor RLA ⁶	Cond. Fans			Terminal Block (STD)	Circuit Breaker (OPT)
				Qty.	FLA (EA)		Qty.	FLA (EA)			
0157	200	60	254	4	6.5	254	4	6.5	1.8	30KA	100KA
	230	60	220	4	5.6	220	4	5.6	1.8	30KA	100KA
	575	60	88	4	2.2	88	4	2.2	1.8	30KA	42KA
0177	200	60	257	5	6.5	281	4	6.5	1.8	30KA	100KA
	230	60	223	5	5.6	244	4	5.6	1.8	30KA	100KA
	575	60	89	5	2.2	97	4	2.2	1.8	30KA	42KA
0187	200	60	356	5	6.5	242	5	6.5	1.8	30KA	100KA
	230	60	308	5	5.6	210	5	5.6	1.8	30KA	100KA
	575	60	123	5	2.2	84	5	2.2	1.8	30KA	42KA
0197	200	60	326	5	6.5	326	5	6.5	1.8	30KA	100KA
	230	60	283	5	5.6	283	5	5.6	1.8	30KA	100KA
	575	60	113	5	2.2	113	5	2.2	1.8	30KA	42KA
0207	200	60	327	6	6.5	353	5	6.5	1.8	30KA	100KA
	230	60	283	6	5.6	306	5	5.6	1.8	30KA	100KA
	575	60	113	6	2.2	122	5	2.2	1.8	30KA	42KA
0227	200	60	347	6	6.5	347	6	6.5	1.8	30KA	100KA
	230	60	301	6	5.6	301	6	5.6	1.8	30KA	100KA
	575	60	120	6	2.2	120	6	2.2	1.8	30KA	42KA
0247	200	60	449	6	6.5	344	6	6.5	1.8	30KA	100KA
	230	60	389	6	5.6	298	6	5.6	1.8	30KA	100KA
	575	60	155	6	2.2	119	6	2.2	1.8	30KA	42KA

See page 142 for Electrical Data footnotes.

HIGH EFFICIENCY UNITS

YCAV E/V	Field Wiring & Protection				Field Wiring Lugs		Field Wiring Lugs	
					STD Terminal Block		OPT Circuit Breaker	
	Min Ckt. Ampacity (MCA) ⁴	Recommended Fuse/Ckt. Brkr Rating ⁵	Max. Inverse Time Ckt. Brkr. Rating ²	Max Dual Element Fuse Size ³	Lugs/Phase ¹	Lug Wire Range	Lugs/Phase ¹	Lug Wire Range
0157	624	700	1600	1000	4	2AWG - 600 kcmil	4	4/0AWG - 500 kcmil
	540	600	1600	1000	4	2AWG - 600 kcmil	4	4/0AWG - 500 kcmil
	216	250	500	350	2	2AWG - 600 kcmil	2	2/0AWG - 500 kcmil
0177	661	800	1600	1200	4	2AWG - 600 kcmil	4	4/0AWG - 500 kcmil
	572	700	1600	1000	4	2AWG - 600 kcmil	4	4/0AWG - 500 kcmil
	229	250	600	400	2	2AWG - 600 kcmil	2	2/0AWG - 500 kcmil
0187	751	1000	1600	1200	4	2AWG - 600 kcmil	4	4/0AWG - 500 kcmil
	651	800	1600	1200	4	2AWG - 600 kcmil	4	4/0AWG - 500 kcmil
	260	300	600	450	2	2AWG - 600 kcmil	2	2/0AWG - 500 kcmil
0197	799	1000	1600	1600	4	2AWG - 600 kcmil	4	4/0AWG - 500 kcmil
	692	800	1600	1200	4	2AWG - 600 kcmil	4	4/0AWG - 500 kcmil
	277	350	700	450	2	2AWG - 600 kcmil	2	2/0AWG - 500 kcmil
0207	832	1000	1600	1600	4	2AWG - 600 kcmil	4	4/0AWG - 500 kcmil
	721	800	1600	1200	4	2AWG - 600 kcmil	4	4/0AWG - 500 kcmil
	288	350	700	500	2	2AWG - 600 kcmil	2	2/0AWG - 500 kcmil
0227	859	1000	1600	1600	4	2AWG - 600 kcmil	4	4/0AWG - 500 kcmil
	744	1000	1600	1200	4	2AWG - 600 kcmil	4	4/0AWG - 500 kcmil
	297	350	700	500	2	2AWG - 600 kcmil	2	2/0AWG - 500 kcmil
0247	982	1200	1600	1600	4	2AWG - 600 kcmil	4	4/0AWG - 500 kcmil
	851	1000	1600	1600	4	2AWG - 600 kcmil	4	4/0AWG - 500 kcmil
	340	400	800	600	2	2AWG - 600 kcmil	2	2/0AWG - 500 kcmil

Electrical Data - 3 Comp - 60Hz

STANDARD EFFICIENCY

Model No./Nameplate			System 1			System 2			System 3		
			Comp.	Cond. Fans		Comp.	Cond. Fans		Comp.	Cond. Fans	
YCAV	Volts (11)	Freq	RLA (6)	Qty.	FLA (EA)	RLA (6)	Qty.	FLA (EA)	RLA (6)	Qty.	FLA (EA)
0287	575	60	117	5	2.2	131	4	2.2	86	4	2.2
0307	575	60	118	5	2.2	118	5	2.2	132	4	2.2
0357	575	60	129	5	2.2	129	5	2.2	155	6	2.2
0397	575	60	153	6	2.2	153	6	2.2	153	6	2.2

HIGH EFFICIENCY

Model No./Nameplate			System 1			System 2			System 3		
			Comp.	Cond. Fans		Comp.	Cond. Fans		Comp.	Cond. Fans	
YCAV	Volts (11)	Freq	RLA (6)	Qty.	FLA (EA)	RLA (6)	Qty.	FLA (EA)	RLA (6)	Qty.	FLA (EA)
0267	575	60	114	5	2.2	114	5	2.2	84	4	2.2
0287	575	60	110	5	2.2	110	5	2.2	110	5	2.2
0327	575	60	122	5	2.2	122	5	2.2	113	6	2.2
0357	575	60	146	6	2.2	146	6	2.2	111	6	2.2

See page 142 for Electrical Data footnotes.

STANDARD EFFICIENCY

Control	Unit Short Circuit Withstand (KA)		Field Wiring & Protection				Field Wiring Lugs STD Terminal Block		Field Wiring Lugs OPT Circuit Breaker	
	KVA (8)	Terminal Block (STD)	Circuit Breaker (OPT)	Minimum Ckt. Ampacity (MCA) (4)	Recommended Fuse/Ckt. Breaker Rating (5)	Max. Inverse Time Ckt. Brkr. Rating (2)	Max Dual Element Fuse Size (3)	Lugs/Phase (1)	Lug Wire Range	Lugs/Phase (1)
2.4	30KA	42KA	396	450	800	700	3	#2 - 600 KCM	3	#3/0 - 400 KCM
2.4	30KA	42KA	433	500	800	800	3	#2 - 600 KCM	3	#3/0 - 400 KCM
2.4	30KA	42KA	487	600	1000	800	3	#2 - 600 KCM	3	#3/0 - 400 KCM
2.4	30KA	42KA	538	600	1000	1000	3	#2 - 600 KCM	3	#3/0 - 400 KCM

HIGH EFFICIENCY

Control	Unit Short Circuit Withstand (KA)		Field Wiring & Protection				Field Wiring Lugs STD Terminal Block		Field Wiring Lugs OPT Circuit Breaker	
	KVA (8)	Terminal Block (STD)	Circuit Breaker (OPT)	Minimum Ckt. Ampacity (MCA) (4)	Recommended Fuse/Ckt. Breaker Rating (5)	Max. Inverse Time Ckt. Brkr. Rating (2)	Max Dual Element Fuse Size (3)	Lugs/Phase (1)	Lug Wire Range	Lugs/Phase (1)
2.4	30KA	42KA	371	450	800	700	3	#2 - 600 KCM	3	#3/0 - 400 KCM
2.4	30KA	42KA	389	450	800	700	3	#2 - 600 KCM	3	#3/0 - 400 KCM
2.4	30KA	42KA	424	500	800	800	3	#2 - 600 KCM	3	#3/0 - 400 KCM
2.4	30KA	42KA	479	600	1000	800	3	#2 - 600 KCM	3	#3/0 - 400 KCM

Electrical Data - 4 Comp - 60Hz

SINGLE POINT WIRING

Standard Efficiency YCAV____ S/P Single Point Wiring																
Model No./Nameplate			System 1			System 2			System 3			System 4			Control	
			Comp.	Cond. Fans		Comp.	Cond. Fans		Comp.	Cond. Fans		Comp.	Cond. Fans		Sys 1/3	Sys 2/4
YCAV	Volts ¹¹	Freq	RLA ⁶	Qty.	FLA (EA)	RLA ⁶	Qty.	FLA (EA)	RLA ⁶	Qty.	FLA (EA)	RLA ⁶	Qty.	FLA (EA)	KVA ⁸	KVA ⁸
0417	380	60	198	5	3.5	198	5	3.5	198	5	3.5	198	5	3.5	2.4	1.8
	460	60	156	5	2.8	156	5	2.8	156	5	2.8	156	5	2.8	2.4	1.8
	575	60	125	5	2.2	125	5	2.2	125	5	2.2	125	5	2.2	2.4	1.8
0457	380	60	228	6	3.5	228	5	3.5	190	5	3.5	190	5	3.5	2.4	1.8
	460	60	180	6	2.8	180	5	2.8	150	5	2.8	150	5	2.8	2.4	1.8
	575	60	144	6	2.2	144	5	2.2	120	5	2.2	120	5	2.2	2.4	1.8
0477	380	60	244	6	3.5	244	6	3.5	202	5	3.5	202	5	3.5	2.4	1.8
	460	60	193	6	2.8	193	6	2.8	160	5	2.8	160	5	2.8	2.4	1.8
	575	60	155	6	2.2	155	6	2.2	128	5	2.2	128	5	2.2	2.4	1.8
0507	380	60	243	6	3.5	243	6	3.5	202	5	3.5	243	6	3.5	2.4	1.8
	460	60	192	6	2.8	191	6	2.8	159	5	2.8	191	6	2.8	2.4	1.8
	575	60	154	6	2.2	154	6	2.2	128	5	2.2	154	6	2.2	2.4	1.8
0527	380	60	242	6	3.5	242	6	3.5	242	6	3.5	242	6	3.5	2.4	1.8
	460	60	191	6	2.8	191	6	2.8	191	6	2.8	191	6	2.8	2.4	1.8
	575	60	153	6	2.2	153	6	2.2	153	6	2.2	153	6	2.2	2.4	1.8

High Efficiency YCAV____ E/V Single Point																
Model No./Nameplate			System 1			System 2			System 3			System 4			Control	
			Comp.	Cond. Fans		Comp.	Cond. Fans		Comp.	Cond. Fans		Comp.	Cond. Fans		Sys 1/3	Sys 2/4
YCAV	Volts ¹¹	Freq	RLA ⁶	Qty.	FLA (EA)	RLA ⁶	Qty.	FLA (EA)	RLA ⁶	Qty.	FLA (EA)	RLA ⁶	Qty.	FLA (EA)	KVA ⁸	KVA ⁸
0397	380	60	173	5	3.5	173	5	3.5	173	5	3.5	173	5	3.5	2.4	1.8
	460	60	137	5	2.8	136	5	2.8	137	5	2.8	136	5	2.8	2.4	1.8
	575	60	109	5	2.2	109	5	2.2	109	5	2.2	109	5	2.2	2.4	1.8
0417	380	60	179	6	3.5	179	6	3.5	193	5	3.5	193	5	3.5	2.4	1.8
	460	60	141	6	2.8	141	6	2.8	153	5	2.8	152	5	2.8	2.4	1.8
	575	60	113	6	2.2	113	6	2.2	122	5	2.2	122	5	2.2	2.4	1.8
0477	380	60	231	6	3.5	231	6	3.5	177	6	3.5	177	6	3.5	2.4	1.8
	460	60	182	6	2.8	182	6	2.8	139	6	2.8	139	6	2.8	2.4	1.8
	575	60	146	6	2.2	146	6	2.2	112	6	2.2	112	6	2.2	2.4	1.8

See page 142 for Electrical Data footnotes.

SINGLE POINT WIRING

Standard Efficiency YCAV_ _ _ _ S/P Single Point Wiring									
Unit Short Circuit Withstand (KA)		Field Wiring & Protection				Field Wiring Lugs STD Terminal Block		Field Wiring Lugs OPT Circuit Breaker	
Terminal Block (STD)	Circuit Breaker (OPT)	Minimum Ckt. Ampacity (MCA) ⁴	Recommended Fuse/Ckt. Breaker Rating ⁵	Max. Inverse Time Ckt. Brkr. Rating ²	Max Dual Element Fuse Size ³	Lugs/Phase ¹	Lug Wire Range	Lugs/Phase ¹	Lug Wire Range
30KA	65KA	911	1000	2000	1600	4	#1/0-750 KCM	4	#1/0-750 KCM
30KA	65KA	719	800	1600	1200	4	#1/0-750 KCM	4	#1/0-750 KCM
30KA	42KA	577	700	1200	1000	4	#1/0-750 KCM	4	#1/0-750 KCM
30KA	65KA	967	1200	2000	1600	4	#1/0-750 KCM	4	#1/0-750 KCM
30KA	65KA	763	1000	1600	1200	4	#1/0-750 KCM	4	#1/0-750 KCM
30KA	42KA	612	700	1200	1200	4	#1/0-750 KCM	4	#1/0-750 KCM
30KA	65KA	1032	1200	2000	2000	4	#1/0-750 KCM	4	#1/0-750 KCM
30KA	65KA	815	1000	1600	1600	4	#1/0-750 KCM	4	#1/0-750 KCM
30KA	42KA	653	700	1200	1200	4	#1/0-750 KCM	4	#1/0-750 KCM
30KA	65KA	1073	1200	2000	2000	4	#1/0-750 KCM	4	#1/0-750 KCM
30KA	65KA	847	1000	1600	1600	4	#1/0-750 KCM	4	#1/0-750 KCM
30KA	42KA	679	800	1200	1200	4	#1/0-750 KCM	4	#1/0-750 KCM
30KA	65KA	1113	1200	2000	2000	4	#1/0-750 KCM	4	#1/0-750 KCM
30KA	65KA	878	1000	1600	1600	4	#1/0-750 KCM	4	#1/0-750 KCM
30KA	42KA	705	800	1200	1200	4	#1/0-750 KCM	4	#1/0-750 KCM

High Efficiency YCAV_ _ _ _ E/V Single Point									
Unit Short Circuit Withstand (KA)		Field Wiring & Protection				Field Wiring Lugs STD Terminal Block		Field Wiring Lugs OPT Circuit Breaker	
Terminal Block (STD)	Circuit Breaker (OPT)	Minimum Ckt. Ampacity (MCA) ⁴	Recommended Fuse/Ckt. Breaker Rating ⁵	Max. Inverse Time Ckt. Brkr. Rating ²	Max Dual Element Fuse Size ³	Lugs/Phase ¹	Lug Wire Range	Lugs/Phase ¹	Lug Wire Range
30KA	65KA	805	1000	1600	1600	4	#1/0-750 KCM	4	#1/0-750 KCM
30KA	65KA	636	700	1200	1200	4	#1/0-750 KCM	4	#1/0-750 KCM
30KA	42KA	510	600	1000	1000	4	#1/0-750 KCM	4	#1/0-750 KCM
30KA	65KA	869	1000	1600	1600	4	#1/0-750 KCM	4	#1/0-750 KCM
30KA	65KA	687	800	1200	1200	4	#1/0-750 KCM	4	#1/0-750 KCM
30KA	42KA	551	600	1200	1000	4	#1/0-750 KCM	4	#1/0-750 KCM
30KA	65KA	957	1200	2000	1600	4	#1/0-750 KCM	4	#1/0-750 KCM
30KA	65KA	756	1000	1600	1200	4	#1/0-750 KCM	4	#1/0-750 KCM
30KA	42KA	606	700	1200	1200	4	#1/0-750 KCM	4	#1/0-750 KCM

STANDARD EFFICIENCY - 4 COMPRESSOR UNITS (SEE FIG. 1) - Dual Point

Field Wiring & Protection								Field Wiring Lugs STD Terminal Blocks				Field Wiring Lugs OPT Circuit Breakers			
Minimum Ckt. Ampacity (MCA) (4)		Recommended Fuse/Ckt. Breaker Rating (5)		Max. Inverse Time Ckt. Brkr. Rating (2)		Max Dual Element Fuse Size (3)		Lugs/Phase (1)		Lug Wire Range		Lugs/Phase (1)		Lug Wire Range	
Sys 1/3	Sys 2/4	Sys 1/3	Sys 2/4	Sys 1/3	Sys 2/4	Sys 1/3	Sys 2/4	Sys 1/3	Sys 2/4	Sys 1/3	Sys 2/4	Sys 1/3	Sys 2/4	Sys 1/3	Sys 2/4
456	456	600	600	800	800	800	800	3	3	#2-600 KCM	#2-600 KCM	3	3	#3/0-400 KCM	#3/0-400 KCM
488	484	600	600	1000	1000	800	800	3	3	#2-600 KCM	#2-600 KCM	3	3	#3/0-400 KCM	#3/0-400 KCM
519	519	600	600	1000	1000	800	800	3	3	#2-600 KCM	#2-600 KCM	3	3	#3/0-400 KCM	#3/0-400 KCM
518	558	600	700	1000	1000	800	1000	3	3	#2-600 KCM	#2-600 KCM	3	3	#3/0-400 KCM	#3/0-400 KCM
557	557	700	700	1000	1000	1000	1000	3	3	#2-600 KCM	#2-600 KCM	3	3	#3/0-400 KCM	#3/0-400 KCM

STANDARD EFFICIENCY - 4 COMPRESSOR UNITS (SEE FIG. 1) - Single Point

FIELD WIRING & PROTECTION				FIELD WIRING LUGS STD TERMINAL BLOCK		FIELD WIRING LUGS OPT CIRCUIT BREAKER	
MINIMUM CKT. AMPACITY (MCA) (4)	RECOMMENDED FUSE/CKT. BREAKER RATING (5)	MAX. INVERSE TIME CKT. BRKR. RATING (2)	MAX DUAL ELEMENT FUSE SIZE (3)	LUGS/PHASE (1)	LUG WIRE RANGE	LUGS/PHASE (1)	LUG WIRE RANGE
865	1000	1600	1600	4	#1/0-750 KCM	4	#1/0-750 KCM
918	1000	2000	1600	4	#1/0-750 KCM	4	#1/0-750 KCM
980	1200	2000	1600	4	#1/0-750 KCM	4	#1/0-750 KCM
1018	1200	2000	2000	4	#1/0-750 KCM	4	#1/0-750 KCM
1057	1200	2000	2000	4	#1/0-750 KCM	4	#1/0-750 KCM

HIGH EFFICIENCY 4-Compressor Units - Dual Point

Field Wiring & Protection								Field Wiring Lugs STD Terminal Blocks				Field Wiring Lugs OPT Circuit Breakers			
Minimum Ckt. Ampacity (MCA) (4)		Recommended Fuse/Ckt. Breaker Rating (5)		Max. Inverse Time Ckt. Brkr. Rating (2)		Max Dual Element Fuse Size (3)		Lugs/Phase (1)		Lug Wire Range		Lugs/Phase (1)		Lug Wire Range	
Sys 1/3	Sys 2/4	Sys 1/3	Sys 2/4	Sys 1/3	Sys 2/4	Sys 1/3	Sys 2/4	Sys 1/3	Sys 2/4	Sys 1/3	Sys 2/4	Sys 1/3	Sys 2/4	Sys 1/3	Sys 2/4
403	403	450	450	800	800	700	700	3	3	#2-600 KCM	#2-600 KCM	3	3	#3/0-400 KCM	#3/0-400 KCM
436	436	500	500	800	800	800	800	3	3	#2-600 KCM	#2-600 KCM	3	3	#3/0-400 KCM	#3/0-400 KCM
482	482	600	600	1000	1000	800	800	3	3	#2-600 KCM	#2-600 KCM	3	3	#3/0-400 KCM	#3/0-400 KCM

HIGH EFFICIENCY 4-Compressor Units - Single Point

FIELD WIRING & PROTECTION				FIELD WIRING LUGS STD TERMINAL BLOCK		FIELD WIRING LUGS OPT CIRCUIT BREAKER	
MINIMUM CKT. AMPACITY (MCA) (4)	RECOMMENDED FUSE/CKT. BREAKER RATING (5)	MAX. INVERSE TIME CKT. BRKR. RATING (2)	MAX DUAL ELEMENT FUSE SIZE (3)	LUGS/PHASE (1)	LUG WIRE RANGE	LUGS/PHASE (1)	LUG WIRE RANGE
765	1000	1600	1200	4	#1/0-750 KCM	4	#1/0-750 KCM
826	1000	1600	1600	4	#1/0-750 KCM	4	#1/0-750 KCM
909	1000	2000	1600	4	#1/0-750 KCM	4	#1/0-750 KCM

Electrical Notes

- As standard, all units have single point power connection for two and three compressor systems and dual point for four compressor systems (with single point as an option). Contact factory for information regarding dual point power units.
- Maximum Inverse Time Circuit Breaker - 250% of the rated input current of the drive per NEC 430.52 (C1).
- Maximum Dual Element (Time Delay) Fuse - 225% of the rated input current of the drive per NEC 430.52 (C1).
- MCA - Minimum Circuit Ampacity - 125% of the largest compressor RLA plus 100% of the remaining compressor RLA's plus the sum of all condenser fan FLA's per NEC 440.33
- Recommended time delay or dual element fuse size - 150% of the largest compressor RLA plus 100% of the remaining compressor RLA's plus the sum of all condenser fan FLA's.
- RLA - Rated Load Amps - rated in accordance with UL standard 1995.
- Local codes may take precedence.
- Control KVA includes operational controls and evaporator heaters.
- System inrush current is less than RLA due to the use of York Variable Speed Drive technology. Typical Compressor Starting Current (first four seconds of startup):

Rated Voltage	Typical Starting Current per Compressor
200/60/3	53A
230/60/3	46A
380/60/3	29A
460/60/3	23A
575/60/3	18A
400/50/3	28A
- Optional Compressor Service Disconnect switch is available on all units.
- Voltage Utilization Range:

Rated Voltage	Utilization Range
200/60/3	180-220
230/60/3	208-254
380/60/3	342-402
460/60/3	414-508
575/60/3	520-635
400/50/3	360-440
- Condenser fan FLA applies to both low sound and ultra quiet fans.

LEGEND

C.B.	CIRCUIT BREAKER
D.E.	DUAL ELEMENT FUSE
DISC SW	DISCONNECT SWITCH
FACT CB	FACTORY-MOUNTED CIRCUIT BREAKER
FLA	FULL LOAD AMPS
HZ	HERTZ
MAX	MAXIMUM
MCA	MINIMUM CIRCUIT AMPACITY
MIN	MINIMUM
MIN NF	MINIMUM NON-FUSED
RLA	RATED LOAD AMPS
S.P. WIRE	SINGLE-POINT WIRING

NOTES:

- U.L. Label is provided on 60 Hz units for these electrical wiring configurations.
- — — — — Dashed Line = Field Provided Wiring.
- The above recommendations are based on the National Electric Code and using copper conductors only. Field wiring must also comply with local codes. Group Rated breaker must be HACR type for cUL machines.

2 COMPRESSOR POWER WIRING CONNECTIONS

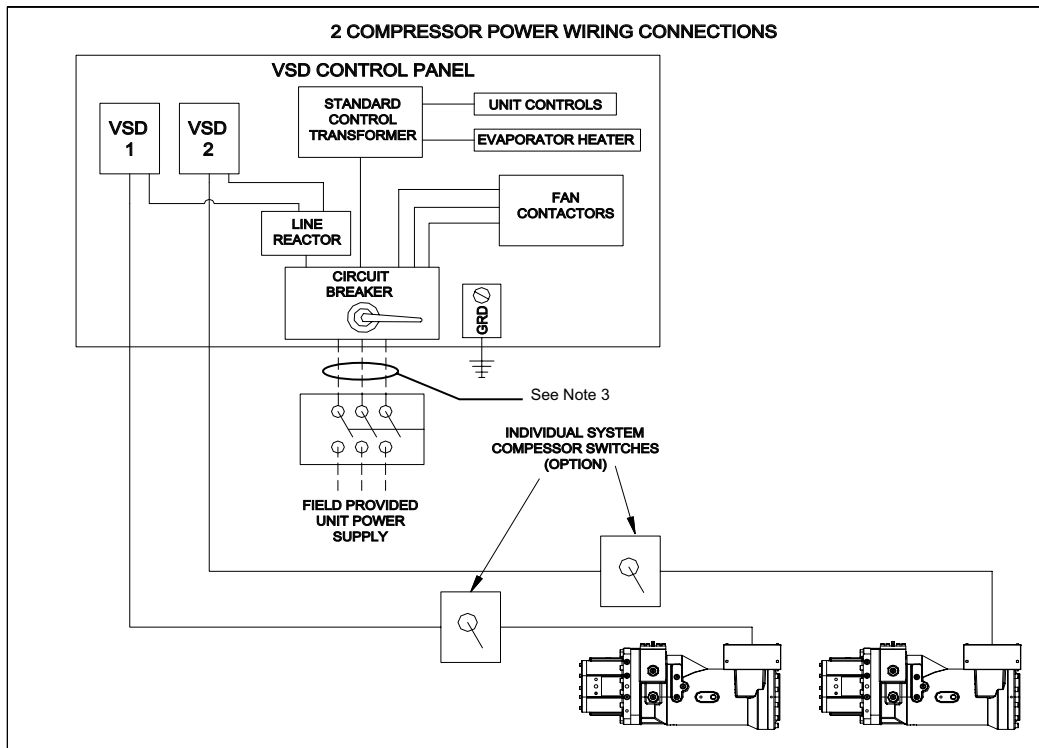

FIG. 1 – TWO COMPRESSOR WIRING DIAGRAM WITH CIRCUIT BREAKER

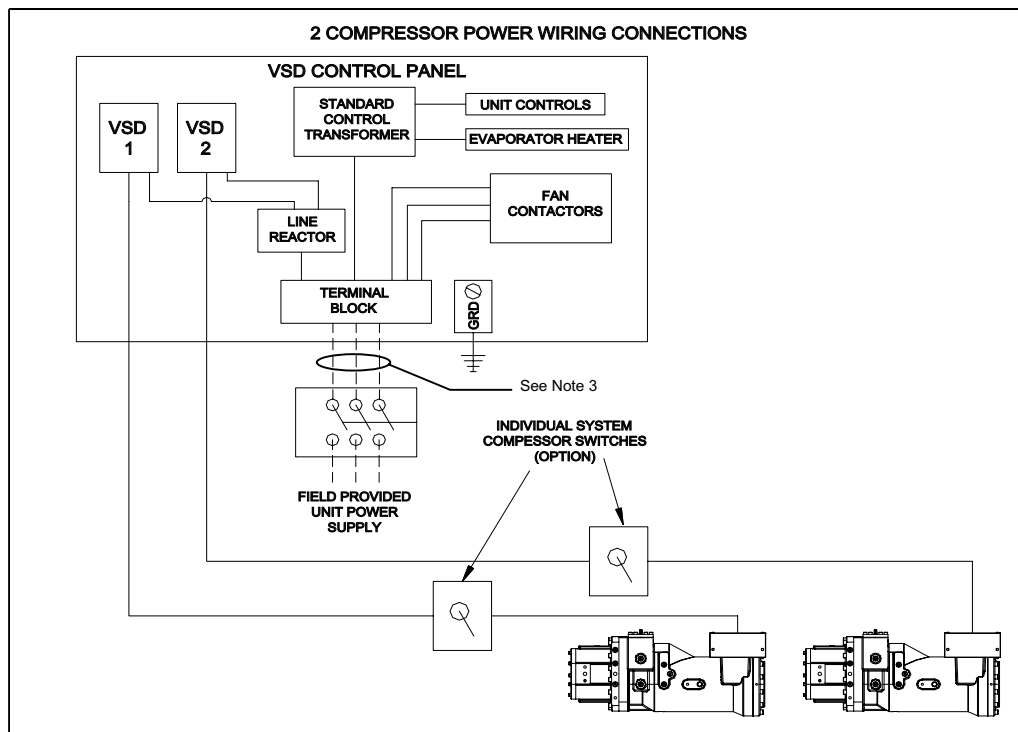

FIG. 2 – TWO COMPRESSOR WIRING DIAGRAM WITH TERMINAL BLOCK

Power Wiring - continued

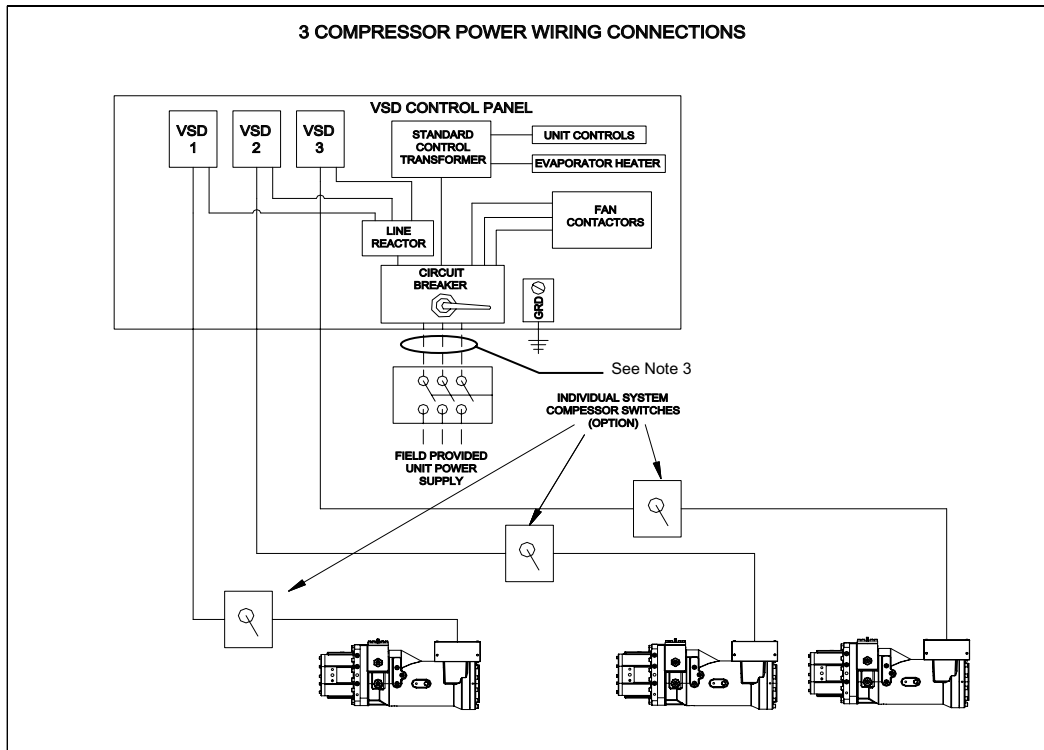

FIG. 3 – THREE COMPRESSOR WIRING DIAGRAM WITH CIRCUIT BREAKER – SINGLE POINT

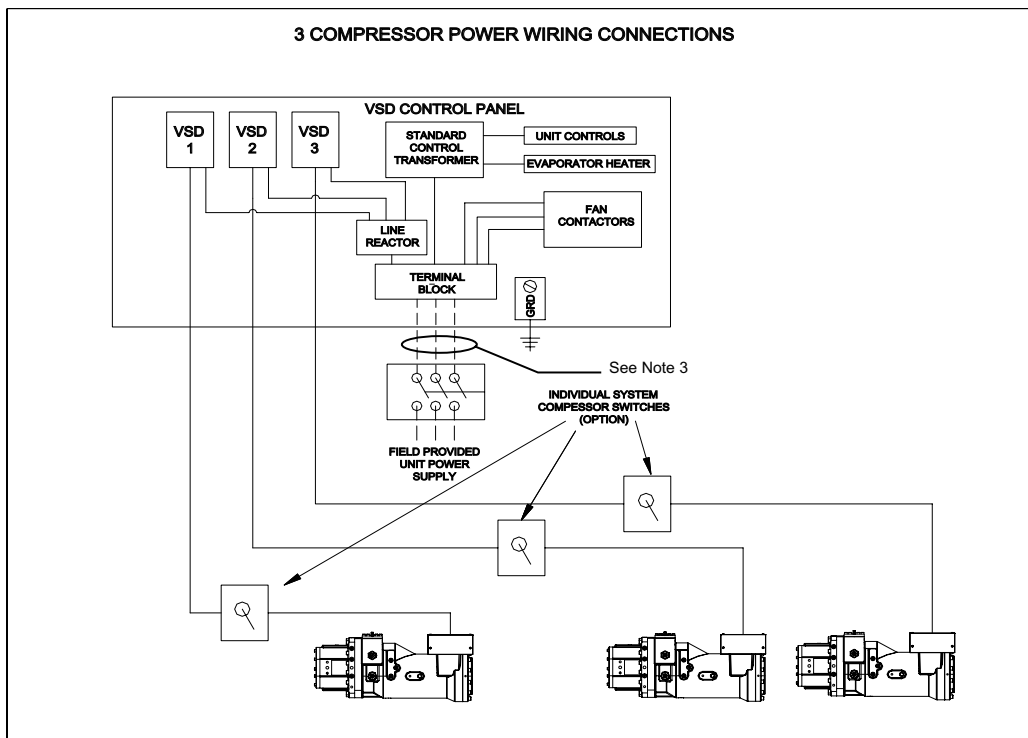

FIG. 4 – THREE COMPRESSOR WIRING DIAGRAM WITH TERMINAL BLOCK – SINGLE POINT

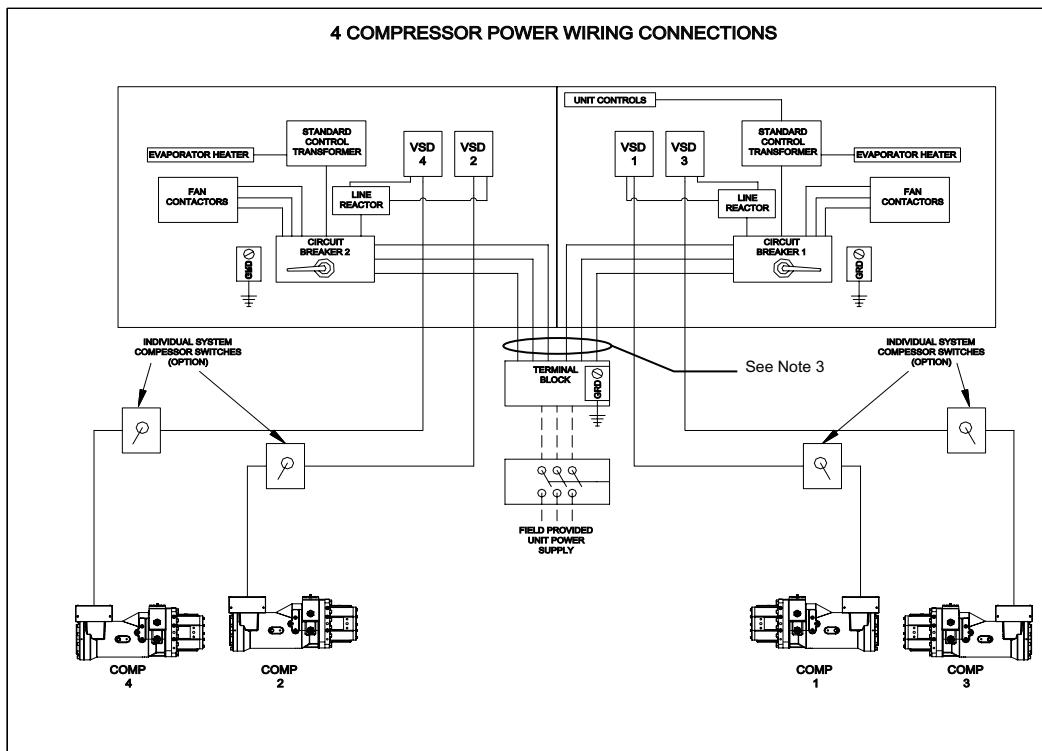

FIG. 5 – FOUR COMPRESSOR WIRING DIAGRAM WITH CIRCUIT BREAKER – SINGLE POINT

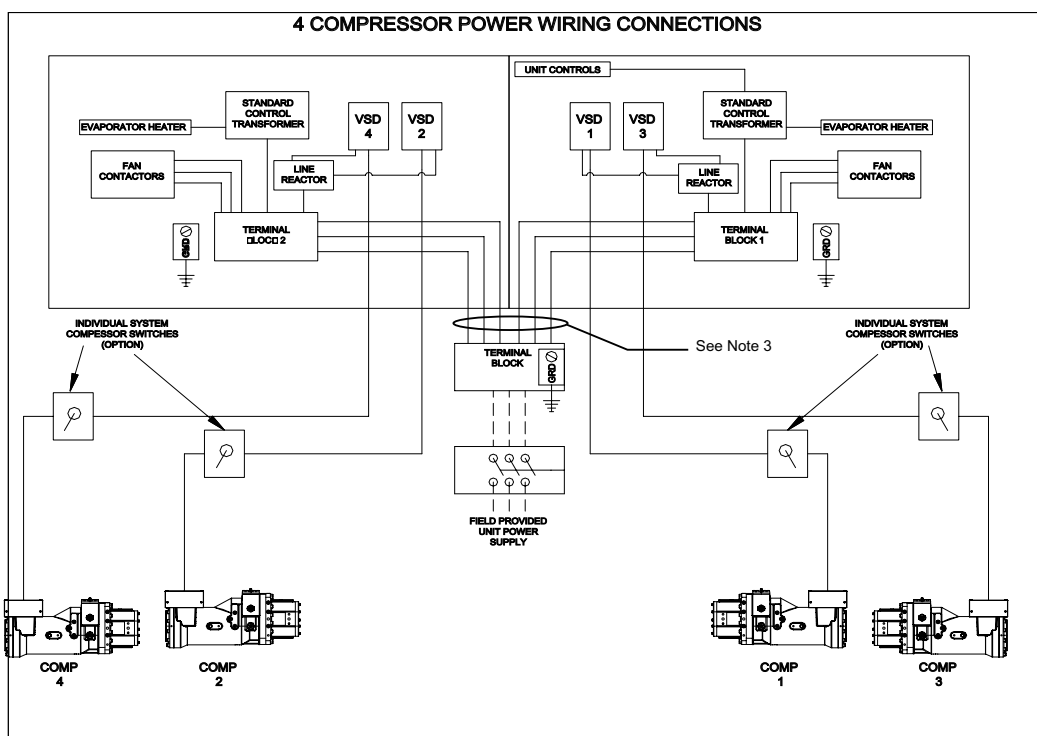

FIG. 6 – FOUR COMPRESSOR WIRING DIAGRAM WITH TERMINAL BLOCK – SINGLE POINT

Power Wiring - continued

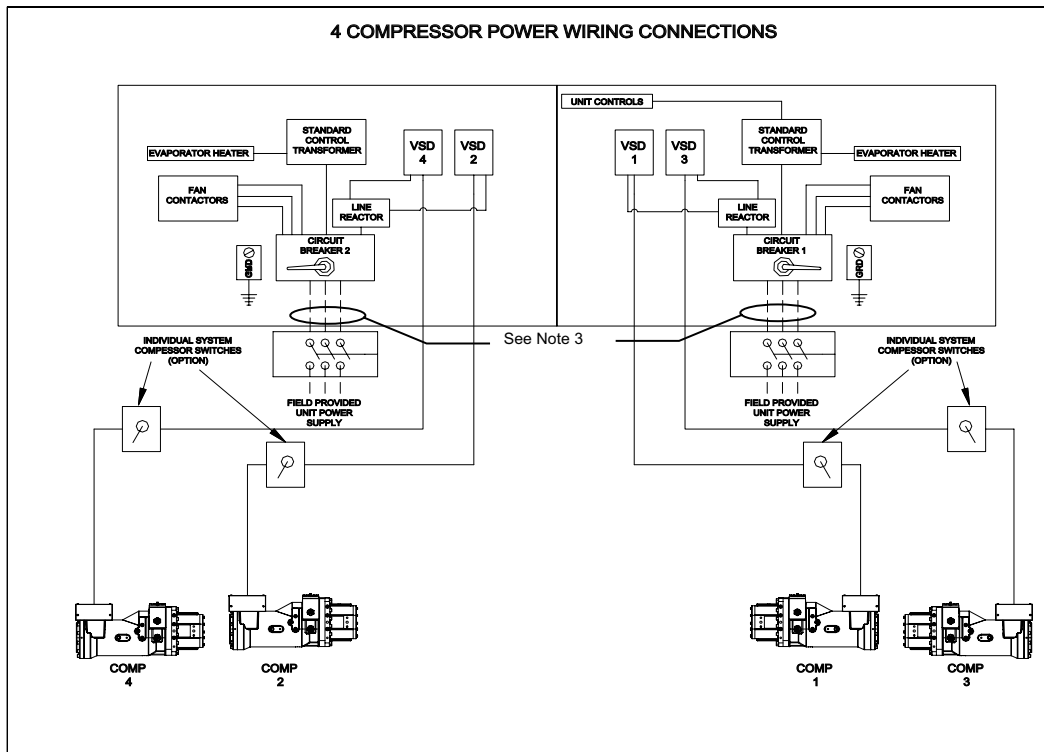

FIG. 7 – FOUR COMPRESSOR WIRING DIAGRAM WITH CIRCUIT BREAKER – MULTI POINT

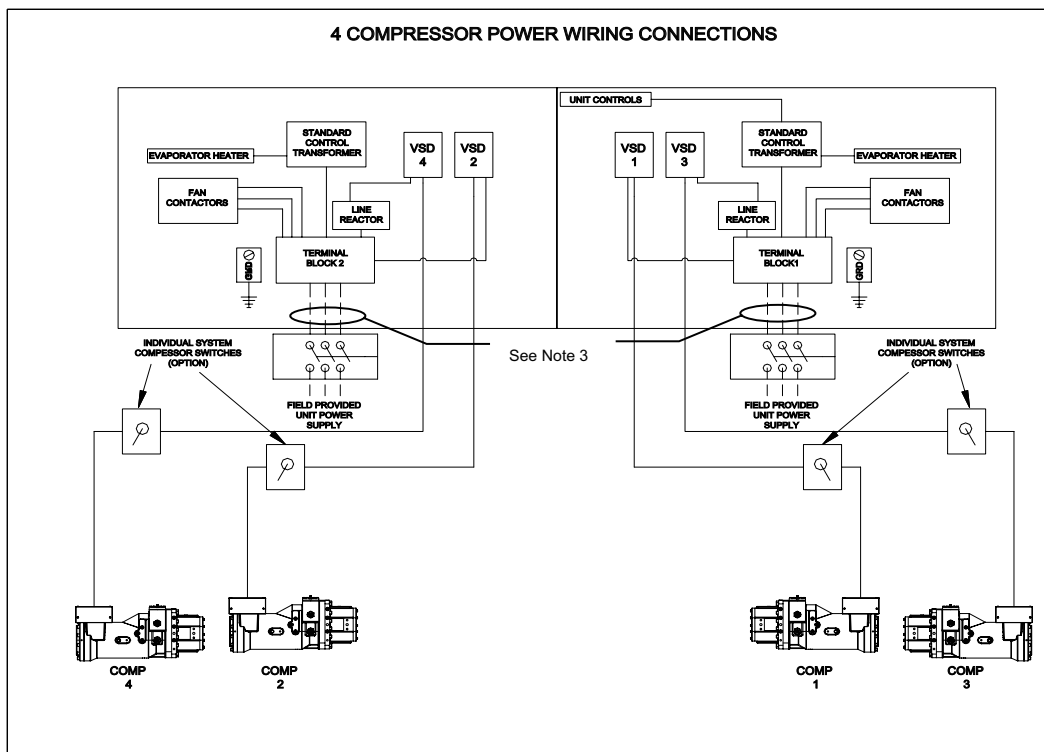
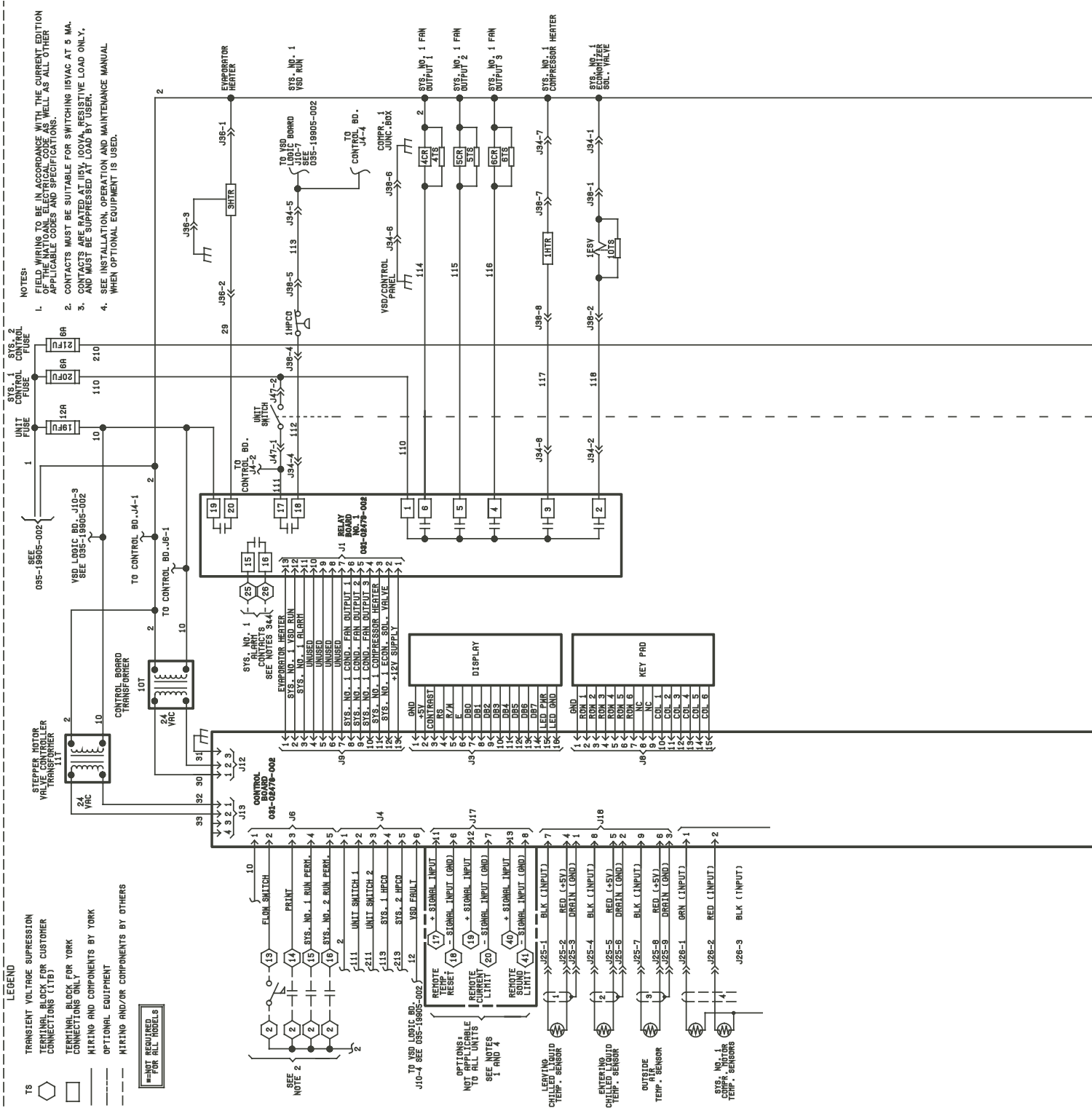
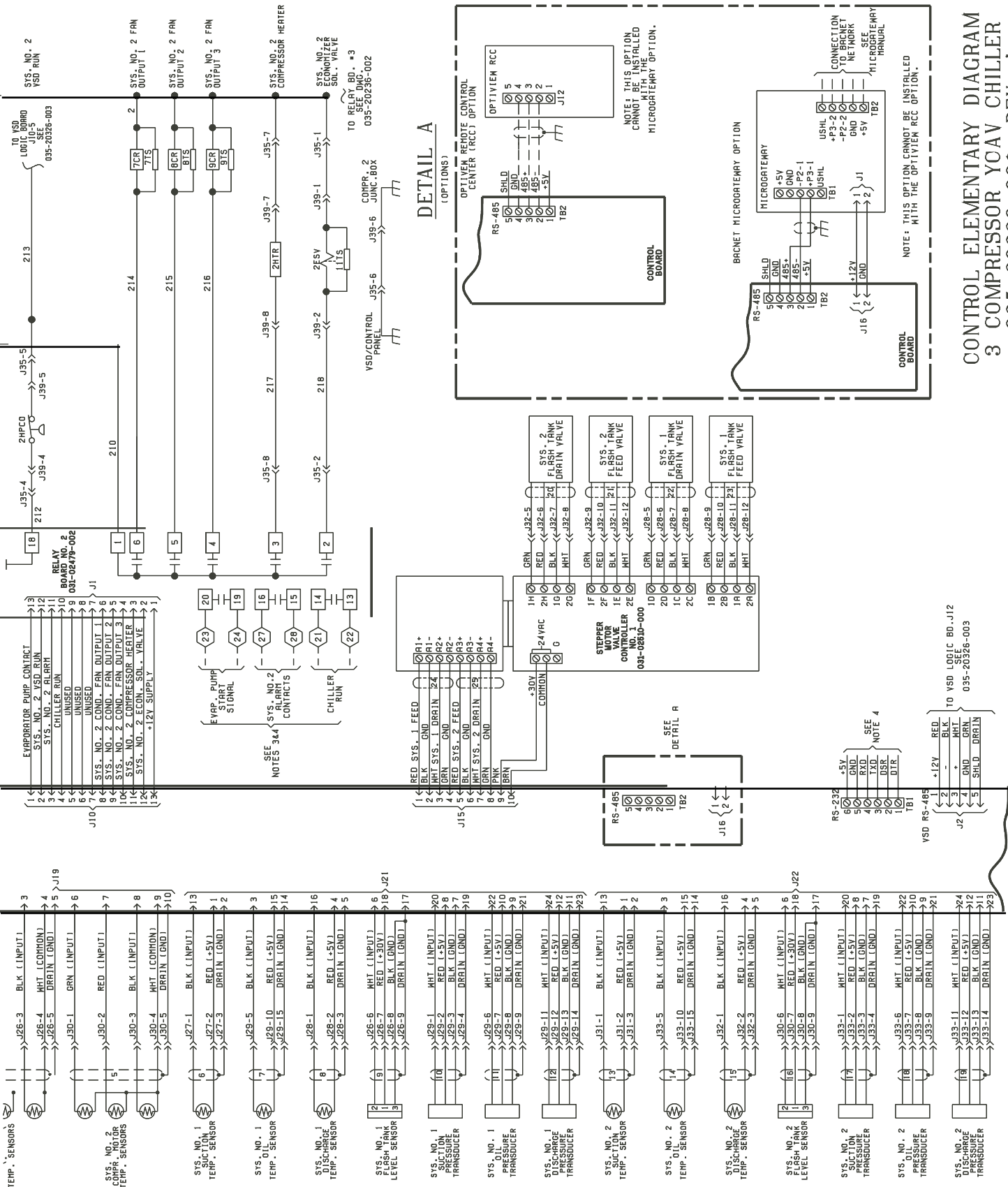

FIG. 8 – FOUR COMPRESSOR WIRING DIAGRAM WITH TERMINAL BLOCK – MULTI POINT

Typical Control Wiring - Two Compressor





CONTROL ELEMENTARY DIAGRAM
3 COMPRESSOR YCAV CHILLER
035-20326-001 REV. A

CONTINUED TO
035-20326-002

For informational purposes only. Do not attempt to tie into wiring without a proper wiring diagram.

Typical Control Wiring - Four Compressor

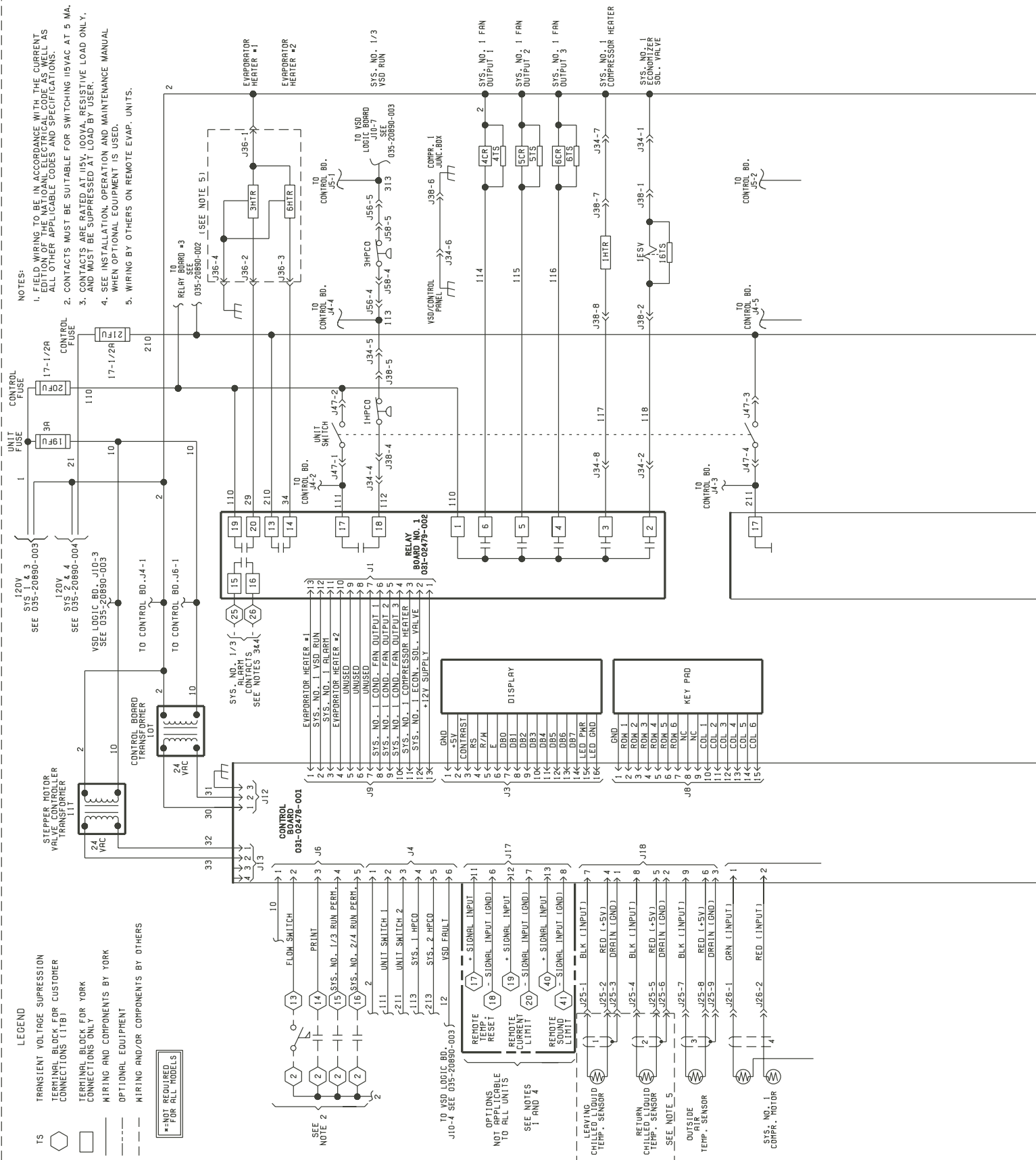

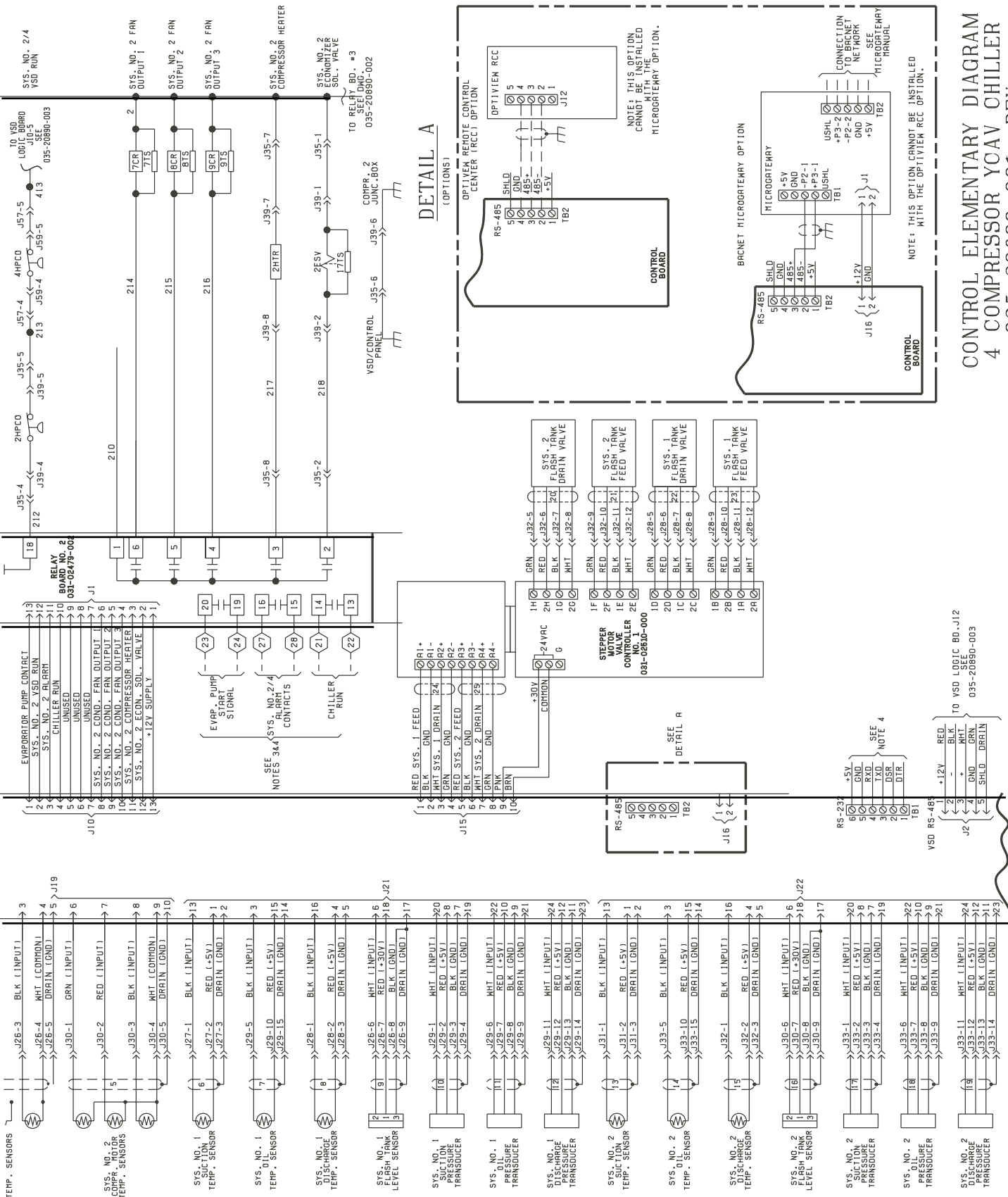

**CONTROL ELEMENTARY DIAGRAM
4 COMPRESSOR YCAV CHILLER
035-20890-001 REV. -**

NOTE: THIS OPTION CANNOT BE INSTALLED WITH THE MICROGRAVITY OPTION.

CONTINUED TO 035-20890-002

For informational purposes only. Do not attempt to tie into wiring without a proper wiring diagram.

Application Data

UNIT LOCATION

The YCAV chillers are designed for outdoor installation. When selecting a site for installation, be guided by the following requirements:

1. Installation sites may be either on a roof or on ground level. (See FOUNDATION)
2. Select a place having an adequate supply of fresh air for the condensers. Recommended clearances for all units are shown on the DIMENSIONS pages.
3. Avoid locations near windows or structures where normal operating sounds may be objectionable.
4. The standard condenser fans are propeller-type and are not recommended for use with ductwork, filters or other impediments to airflow in the condenser air stream.
5. When it is desirable to surround the unit(s), it is recommended that the screening be able to pass the required chiller CFM without exceeding 0.1" external static pressure.
6. Protection against corrosive environments is available by supplying the units with either copper fins, or cured epoxy-coating on the condenser coils. Epoxy-coated coils should be utilized with any units being installed at the seashore, or where salt spray may hit the units, or where acid rain is prevalent (copper condenser coils are not recommended where they may be exposed to acid rain).
7. On installations where winter operation is intended and snow accumulations are expected, additional elevation must be provided to insure normal condenser air flow.

FOUNDATION

The unit should be mounted on a flat and level foundation, ground or roof, capable of supporting the entire operating weight of the equipment. Operating weights are given in the PHYSICAL DATA tables.

Roof Locations – Adequate structural strength to safely support the entire weight of the unit and service personnel must be provided. Care must be taken not to damage the roof during installation. If the roof is “bonded”, consult building contractor or architect for special installation requirements. Roof installations should incorporate the use of spring-type isolators to minimize the transmission of vibration into building structure. Additional support should

be provided to the roof at the spring-isolator locations.

Ground Locations – Units must be installed on a substantial base that will not settle and cause strain on the refrigerant lines, resulting in possible leaks. A one-piece concrete slab, with footers extending below the frost line, is recommended. The slab should not be tied to the main building foundation as noises will telegraph.

Mounting holes (5/8") are provided in the base rails for bolting the unit to its foundation. See DIMENSIONS for location of the mounting holes.

For ground installations, precautions should be taken to protect the unit from tampering by, or injury to, unauthorized persons. Fasteners on access panels will prevent casual tampering; however, further safety precautions, such as unit enclosure options, a fenced-in enclosure, or locking devices on the panels may be advisable. Check local authorities for safety regulations.

CHILLED LIQUID PIPING

The chilled liquid piping system should be laid out so that the circulating pump discharges into the cooler. The inlet and outlet cooler-liquid connections are given in DIMENSIONS. Hand stop valves are recommended for use in all lines to facilitate servicing. Drain connections should be provided at all low points to permit complete drainage of the cooler and system piping.

A strainer (40 mesh) is recommended for use on the INLET line to the cooler, and must be in place at initial operation of the water pumps.

Pressure-gauge connections are recommended for installation in the inlet and outlet water lines. Gauges are not provided with the unit and are to be furnished by others.

Chilled liquid lines exposed to the weather should be wrapped with a supplemental heater cable and insulated, or glycol should be added to the chilled liquid to protect against freezing if low-ambient periods are expected.

A flow switch is available as an accessory on all units. A flow switch must be installed in the leaving water piping of the cooler and must not be used to start and stop the unit.

PART 1 — GENERAL

1.01 SCOPE

- A. The requirements of the General Conditions, Supplementary Conditions, Division 1, and Drawings apply to all work herein.
- B. Provide Microprocessor controlled, twin-screw compressor, air-cooled, liquid chillers of the scheduled capacities as shown and indicated on the Drawings, including but not limited to:
 - 1. Chiller package
 - 2. Charge of refrigerant (Except remote evaporator applications) and oil.
 - 3. Electrical power and control connections
 - 4. Chilled water connections
 - 5. Factory start-up

1.02 QUALITY ASSURANCE

- A. Products shall be Designed, Tested, Rated and Certified in accordance with, and installed in compliance with applicable sections of the following Standards and Codes:
 - 1. ARI 550/590 – Water Chilling Packages Using the Vapor Compression Cycle
 - 2. ARI 370 – Sound Rating of Large Outdoor Refrigerating and Air Conditioning Equipment
 - 3. ANSI/ASHRAE Standard 15 – Safety Code for Mechanical Refrigeration
 - 4. ASHRAE 34 – Number Designation and Safety Classification of Refrigerants
 - 5. ASHRAE 90.1 – Energy Standard for Buildings Except Low-Rise Residential Buildings
 - 6. ANSI/NFPA Standard 70 – National Electrical Code (N.E.C).
 - 7. ASME Boiler and Pressure Vessel Code, Section VIII, Division 1.
 - 8. ASTM A48 – Gray Iron Castings
 - 9. OSHA – Occupational Safety and Health Act
 - 10. Manufactured in facility registered to ISO 9002
 - 11. Conform to Underwriters Laboratories (U.L.) for construction of chillers and provide U.L./cU.L. listing label.
- B. Factory Test: Chiller shall be pressure-tested, evacuated and fully charged with refrigerant and oil, and shall be factory operational run tested with water flowing through the vessel.
- C. Chiller manufacturer shall have a factory trained and supported service organization that is within a 50 mile

radius of the site.

- D. Warranty: Manufacturer shall Warrant all equipment and material of its manufacture against defects in workmanship and material for a period of eighteen (18) months from date of initial start-up or date of shipment, whichever occurs first.

1.03 DELIVERY AND HANDLING

- A. Unit shall be delivered to job site fully assembled and charged with refrigerant (except remote evaporator applications) and oil by the Manufacturer.
- B. During shipment, provide protective covering over vulnerable components. Fit nozzles and open ends with plastic enclosures.
- C. Protect the chiller and its accessories from the weather and dirt exposure during shipment.
- D. Unit shall be stored and handled per Manufacturer's instructions.

PART 2 — PRODUCTS

2.01 GENERAL

- A. Manufacturers: The design shown on the drawings is based on York International. Alternate equipment will be acceptable if their equipment meets the scheduled performance and complies with these specifications. If equipment manufactured by a manufacturer other than that scheduled is utilized, then the Mechanical Contractor shall be responsible for coordinating with the General Contractor and all affected Subcontractors to insure proper provisions for installation of the furnished unit. This coordination shall include, but not be limited to, the following:

- 1. Structural supports for units.
- 2. Piping size and connection/header locations.
- 3. Electrical power requirements and wire/conduit and overcurrent protection sizes.

The Mechanical Contractor shall be responsible for all costs incurred by the General Contractor, Subcontractors, and Consultants to modify the building provisions to accept the furnished units.

- B. Description: Install and commission, as shown on the schedules and plans, factory assembled, charged, and operational tested air cooled screw compressor chiller(s) as specified herein. Chiller shall include, but

Guide Specifications – Contin-

is not limited to: a complete system with multiple independent refrigerant circuits, semihermetic twin screw compressors, shell and tube type evaporator, air-cooled condenser, R134a refrigerant, lubrication system, interconnecting wiring, safety and operating controls including capacity controller, control center, motor starting components, and special features as specified herein or required for safe, automatic operation.

C. Operating Characteristics:

1. Provide low ambient control and high ambient options as required to ensure unit is capable of operation from 0°F to 125°F (-18°C to 52°C) ambient.
2. Provide capacity control system capable of reducing unit capacity to (10% for 2 compressor units, 7.5% for 3 compressor units, and 5% for four compressor units) of full load. Compressor shall start in unloaded condition. Application of factory installed hot gas bypass shall be acceptable as required to meet specified minimum load.

D. Cabinet: Unit panels, structural elements, control boxes and heavy gauge structural base shall be constructed of galvanized steel. Unit panels, control boxes and structural base are finished with a baked on powder paint. All painted surfaces shall be coated with baked on powder paint which, when subject to ASTM B117, 1,000 hour, 5% salt spray test, yields minimum ASTM 1654 rating of "6".

E. Unit shall ship in one piece and shall require installer to provide only a single evaporator inlet and outlet pipe connection. If providing chiller model that ships in multiple pieces, bid shall include all the material and field labor costs for factory authorized personnel to install a trim kit to connect the pieces as well as all interconnecting piping and wiring.

2.02 COMPRESSORS AND MOTORS

A. Compressors: Shall be direct drive, semihermetic, rotary twin-screw type, including: muffler, temperature actuated 'off-cycle' heater, rain-tight terminal box, discharge shut-off service valve, and precision machined cast iron housing mounted on neoprene isolators. Design working pressure of entire compressor, suction to discharge, shall be 380 PSIG (26bar) or higher. Compressor shall be U.L. Recognized.

B. Motors: Refrigerant suction gas cooled accessible hermetic compressor motor, full suction gas flow through 0.006" maximum mesh screen, with inherent internal thermal overload protection and external

current overload on all three phases.

C. Lubrication: External oil separators with no moving parts, 450 PSIG design working pressure, and UL listing. Refrigerant system differential pressure shall provide oil flow through service replaceable, 0.5 micron, full flow, cartridge type oil filter internal to compressor. Filter bypass, less restrictive media, or oil pump not acceptable.

D. Capacity Control: Compressors shall start at minimum load. Provide Microprocessor control to command compressor capacity to balance compressor capacity with cooling load. When required to meet minimum load, hot gas bypass shall be factory installed and integrated into standard control system.

2.03 REFRIGERANT CIRCUIT COMPONENTS

A. Each independent refrigerant circuit shall include: liquid line shutoff valve with charging port, low side pressure relief device, removable core filter-drier, sight glass with moisture indicator, and electronic expansion valve.

B. Chiller manufacturer shall provide independent circuit for each compressor to provide maximum redundancy. If equipment does not have independent circuits per compressor, manufacturer shall provide owner one spare compressor of each unique size.

C. Discharge lines shall be provided with manual compressor shutoff service valves. Acoustical wrap shall be included on the discharge line and oil separators. Suction line shall be covered with closed cell foam insulation.

2.04 HEAT EXCHANGERS

A. Evaporator:

1. Direct expansion type or flooded type shell and tube evaporator with high efficiency copper tubes. Independent refrigerant circuits shall be provided per compressor.
2. Constructed, tested, and stamped in accordance with applicable sections of ASME pressure vessel code for minimum 235 PSIG (16 bar) refrigerant side design working pressure and 150 PSIG (10 bar) water side design working pressure.
3. Shell covered with 3/4" (19mm), flexible, closed-cell insulation, thermal conductivity of 0.26k (BTU/HR-Ft²-°F/in.) maximum. Water nozzles with grooves for mechanical couplings, and insulated by Contractor after pipe installation.
4. Provide vent and drain fittings, and thermostatically controlled heaters to protect to -20°F (-29°C) ambient in off-cycle.

B. Air Cooled Condenser:

1. Coils: Internally enhanced, seamless copper tubes, mechanically expanded into aluminum alloy fins with full height collars. Subcooling coil an integral part of condenser. Design working pressure shall be 450 PSIG (31 bar).
2. Low Sound Fans: Shall be dynamically and statically balanced, direct drive, corrosion resistant glass fiber reinforced composite blades molded into low noise, full airfoil cross section, providing vertical air discharge from extended orifices. Guards of heavy gauge, PVC (polyvinyl chloride) coated or galvanized steel.
3. Fan Motors: High efficiency, direct drive, 3-phase, insulation class "F", current protected, Totally Enclosed Air Over (TEAO), with double sealed, permanently lubricated ball bearings.

(for 4-compressor units).

2. Circuit breakers shall be provided at each point of field power connection. Circuit breakers shall be equipped with lockable handles. The circuit breakers shall be sized to provide the motor branch circuit protection, short circuit protection and ground fault protection for the motor branch-circuit conductors, the motor control apparatus and the motors. The circuit breaker rating shall be in accordance with UL508C. Factory wiring shall be provided from multiple circuit breakers to the system components. Refer to schedule for size and number of power connections. All power connections shall be located in one area of the chiller. If equipment supplied requires power connections in more than one area of the chiller; mechanical contractor is responsible for cost and coordination of any changes to electrical or structural designs.

2.05 POWER AND ELECTRICAL REQUIREMENTS**A. Power/Control Panel:**

1. NEMA 3R (IP14), powder painted steel cabinets with hinged, latched, and gasket sealed outer doors equipped with wind struts for safer servicing. Provide main power connection(s), compressor starters and fan motor contactors, current overloads, and factory wiring.
2. Panel shall include control display access door.

B. Single Point Power (As standard for 2 and 3 compressor, available option for 4 compressor)

1. Provide single point power connection to chiller, shall be 3 phase of scheduled voltage.
2. Circuit breaker shall be provided at point of incoming single point connection to provide disconnecting means AND be sized to provide the motor branch circuit protection, short circuit protection and ground fault protection for the motor branch-circuit conductors, the motor control apparatus and the motors. Circuit breaker shall be equipped with lockable operating handle that shall extend through power panel door so that power may be disconnected without opening any panel doors.

And/OR

B. Multi Point Power (Standard for 4-compressor Units)

1. Provide multi point power connections to chiller, shall be 3 phase of scheduled voltage

- C. Control Transformer: Power panel shall be supplied with a factory mounted and wired control transformer that will supply all unit control voltage from the main unit power supply. Transformer shall utilize scheduled line voltage on the primary side and provide 115V/1Ø on secondary.

- D. Short Circuit Withstand Rating of the chiller electrical enclosure shall be (200V & 230V: 100,000 Amps, 380 & 460V: 65,000 Amps, 575V: 42,000 Amps). Rating shall be in accordance with UL508.

- E. Motor Starters: Motors starters shall be reduced inrush type (Wye-Delta or Solid State) for minimum electrical inrush. Across the line type starters will not be acceptable.

F. Power Factor:

1. Provide equipment with power factor correction capacitors as required to maintain a power factor of 95% at all load conditions.
2. The installing contractor is responsible for additional cost to furnish and install power factor correction capacitors if they are not factory mounted and wired.

- G. Exposed compressor and fan motor power wiring shall be routed through liquid tight conduit.

2.06 CONTROLS**A. General:**

1. Provide automatic control of chiller operation

Guide Specifications – Contin-

including compressor start/stop and load/unload, anti-recycle timers, condenser fans, evaporator pump, evaporator heater, unit alarm contacts and run signal contacts.

2. Chiller shall automatically reset to normal chiller operation after power failure.
3. Unit operating software shall be stored in non-volatile memory. Field programmed set points shall be retained in lithium battery backed real time clock (RTC) memory for minimum 5 years.
4. Alarm contacts shall be provided to remote alert for any unit or system safety fault.

B. Display and Keypad:

1. Provide minimum 80 character liquid crystal display that is both viewable in direct sunlight and has LED backlighting for nighttime viewing. Provide one keypad and display panel per chiller.
2. Display and keypad shall be accessible through display access door without opening main control/electrical cabinet doors.
3. Display shall provide a minimum of unit setpoints, status, electrical data, temperature data, pressures, safety lockouts and diagnostics without the use of a coded display.
4. Descriptions in English (or Spanish or French), numeric data in English (or Metric) units.
5. Sealed keypad shall include unit On/Off switch.

C. Programmable Setpoints (within Manufacturer limits): display language; leaving chilled liquid temperature: setpoint, control range; local or remote control; units of measure; compressor lead/lag; and maximum chilled water setpoint reset temperature range.

D. Display Data: Chiller liquid return and leaving temperatures, ambient, lead compressor identification, clock and schedule, (variable) out of range, remote input indication, chilled liquid reset setpoint, and history data for last ten shutdown faults. Compressor suction, discharge, and oil pressures and temperatures, suction and discharge superheats, percent of full-load, operating hours, starts, and anti-recycle timer status. Status Messages for manual override, unit switch off, compressor run, run permissive, remote controlled shut down, no cooling load, daily/holiday shut down, anti-recycle timer.

E. Predictive Control Points: Unit controls shall avoid safety shutdown when operating outside design

conditions by optimizing the chiller controls and cooling load output to stay online and avoid safety limits being reached. The system shall monitor the following parameters and maintain the maximum cooling output possible without shutdown of the equipment: motor current, suction pressure and discharge pressure.

F. System Safeties: Shall cause individual compressor systems to perform auto-reset shut down; manual reset required after the third trip in 90 minutes. Includes: high discharge pressure or temperature, low suction pressure, high / low motor current, high motor temperature, high pressure switch, high / low differential oil pressure, high oil temperature, low suction superheat, critical sensor malfunction, low or high current, phase loss/single phase power, overload of motor windings, and low voltage.

G. Unit Safeties: Shall be automatic reset and cause compressors to shut down if: high or low ambient, low leaving chilled liquid temperature, under voltage, and flow switch operation. Contractor shall provide flow switch and wiring per chiller manufacturer requirements.

H. Manufacturer shall provide any controls not listed above, necessary for automatic chiller operation. Mechanical Contractor shall provide field control wiring necessary to interface sensors to the chiller control system.

2.07 ACCESSORIES AND OPTIONS

Some accessories and options supersede standard product features. Your YORK representative will be pleased to provide assistance.

A. Sound Reduction

1. Provide the following options as required to meet scheduled sound performance data at all load points.
 - a. Ultra Quiet fans (**Factory Mounted**)
 - b. Compressor Sound Blankets (**Factory Mounted**)
 - c. Acoustical perimeter enclosures (**Field Mounted**)

Chiller Load	Sound Power Levels								A-Weighted (dBA)
	Octave Band Center Frequency, Hz								
	63	125	250	500	1000	2000	4000	8000	
100%									
75%									
50%									
25%									

Sound power octave band data, dB per ARI standard 370.

2. Provide optional control input to limit sound output of the chiller based on time of day. Shall be programmable at the chiller panel or controlled remotely via signal (4-20mA or 0-10 VDC) from BAS system. Chillers without this feature shall be provided with the necessary sound attenuation to meet the scheduled sound performance data at all load points.

B. Power Supply/Connections:

1. Terminal Block Power Connection: Power connections shall be made to a Terminal Block with factory provided interconnecting wiring to chiller components.

C. Condenser Coil Environmental Protection:

1. **PRE-COATED FIN CONDENSER COILS –**
The air-cooled condenser coils are constructed of epoxy-coated aluminum fins.
2. **COPPER FIN –** Provide condenser coils with copper fins in lieu of aluminum fins.
3. **POST-COATED EPOXY DIPPED CONDENSER COILS –** The unit is built with dipped-cured condenser coils.

D. Protective Chiller Panels (Factory Mounted):

1. Louvered Panels (condenser coils only): Painted steel to match unit panels, over external condenser coil faces.
2. Wire Panels (full unit): Heavy gauge, welded wire mesh, coated to resist corrosion, to protect condenser coils from incidental damage and restrict unauthorized access to internal components.
3. Louvered Panels (full unit): Painted steel to match unit panels, to protect condenser coils from incidental damage, visually screen internal components, and prevent unauthorized access to internal components.
4. Louvered/Wire Panels: Louvered steel panels on external condenser coil faces, painted to match unit panels. Heavy gauge, welded wire-mesh, coated to resist corrosion, around base of machine to restrict unauthorized access.

E. Evaporator options:

1. Provide 1-1/2" cooler insulation in lieu of standard 3/4".
2. Provide DX Cooler with 300 PSIG (20.7 bar)

waterside design working pressure in lieu of standard 150 PSIG (10.3 bar).

3. Provide Raised Face Flanges for cooler nozzles:
 - a. 150 PSIG (10.3 bar), welded flanges (field kit, matching pipe flange by contractor).
 - b. 300 PSIG (20.7 bar), welded flanges (factory installed, matching pipe flange by contractor).
 - c. 150 PSIG (10.3 bar), Victaulic™ Flanges (field kit, matching pipe flange by contractor).

- F. Flow Switch (**Field Mounted**): Vapor proof SPDT, NEMA 3R switch [___150 PSIG (10.3 bar) or ___300 PSIG (20.7 bar)], -20°F to 250°F (-28.9°C to 121.1°C).

G. Building Automation System Interface:

1. Chiller to accept 4 to 20mA or 0 to 10 VDC input to reset the leaving chilled liquid temperature, or percent full load amps (current limit). (**Factory Mounted**)
2. Provide chiller with microgateway for an interface to other systems that can share data via BACNet™, the ASHRAE open systems protocol. (**Factory Mounted**)

- H. Multi-Unit Sequence Control (**Field Mounted**): Separate Sequencing control center provided to permit control of up to eight chillers in parallel based on mixed liquid temperature.

I. Vibration Isolation (Field Mounted):

1. Neoprene Isolators.
2. 1 Inch Deflection Spring Isolators: Level adjustable, spring and cage type isolators for mounting under the unit base rails.
3. 2 Inch Deflection Seismic Isolators: Level adjustable, restrained mounts in rugged welded steel housing with vertical and horizontal limit stops. Housings shall be designed to withstand a minimum 1.0g accelerated force in all directions to 2" (50.8 mm).

- J. Provide suction service shut-off valve for each compressor. (**Factory Mounted**)

PART 3 — EXECUTION

3.01 INSTALLATION

- A. General: Rig and Install in full accordance with Manufacturer's requirements, Project drawings, and Contract documents.
- B. Location: Locate chiller as indicated on drawings, including cleaning and service maintenance clearance per

Guide Specifications – Contin-

- Manufacturer instructions. Adjust and level chiller on support structure.
- C. Components: Installing Contractor shall provide and install all auxiliary devices and accessories for fully operational chiller.
- D. Electrical: Coordinate electrical requirements and connections for all power feeds with Electrical Contractor
- (Division 16).
- E. Controls: Coordinate all control requirements and connections with Controls Contractor.
- F. Finish: Installing Contractor shall paint damaged and abraded factory finish with touch-up paint matching factory finish.



P. O. Box 1592, York, Pennsylvania USA 17504-1592
© by Johnson Controls 2006

Tele: 800-861-1001
www.york.com

Subject to change without notice. Printed in USA
ALL RIGHTS RESERVED

Form 201.21-EG1 (107)
Supersedes: 201.21-EG1 (1006)