



**YCWS  
WATER COOLED LIQUID CHILLER**



**HFC-407C**



**89 TONS THROUGH 209 TONS  
313 kW THROUGH 735 kW  
60Hz  
STYLE A**



**ALLY**

## Table of Contents

Introduction .....	3
Specifications .....	4
Accessories & Options .....	7
Design Parameters .....	10
Pressure Drops .....	12
Selection Data .....	14
Ratings (HFC-407C English) .....	16
Ratings (HFC-407C SI) .....	18
Ratings- Brine (30 % Ethylene Glycol) (R-22 English) .....	20
Ratings- Brine (30 % Ethylene Glycol) (R-22 SI) .....	22
Ratings- Brine (30 % Propylene Glycol) (R-22 English) .....	24
Ratings- Brine (30 % Propylene Glycol) (R-22 SI) .....	26
Brine Correction Factors .....	28
Part Load Ratings .....	30
Physical Data .....	32
Isolator Selection Data .....	33
Isolator Details .....	34
Sound Data .....	35
Dimensions (English) .....	36
Electrical Data .....	40
Incoming Wire Range Selections .....	43
Customer Wiring Data .....	46
Typical Control Panel Wiring .....	48
Application Data .....	50
Guide Specifications .....	51

## Nomenclature

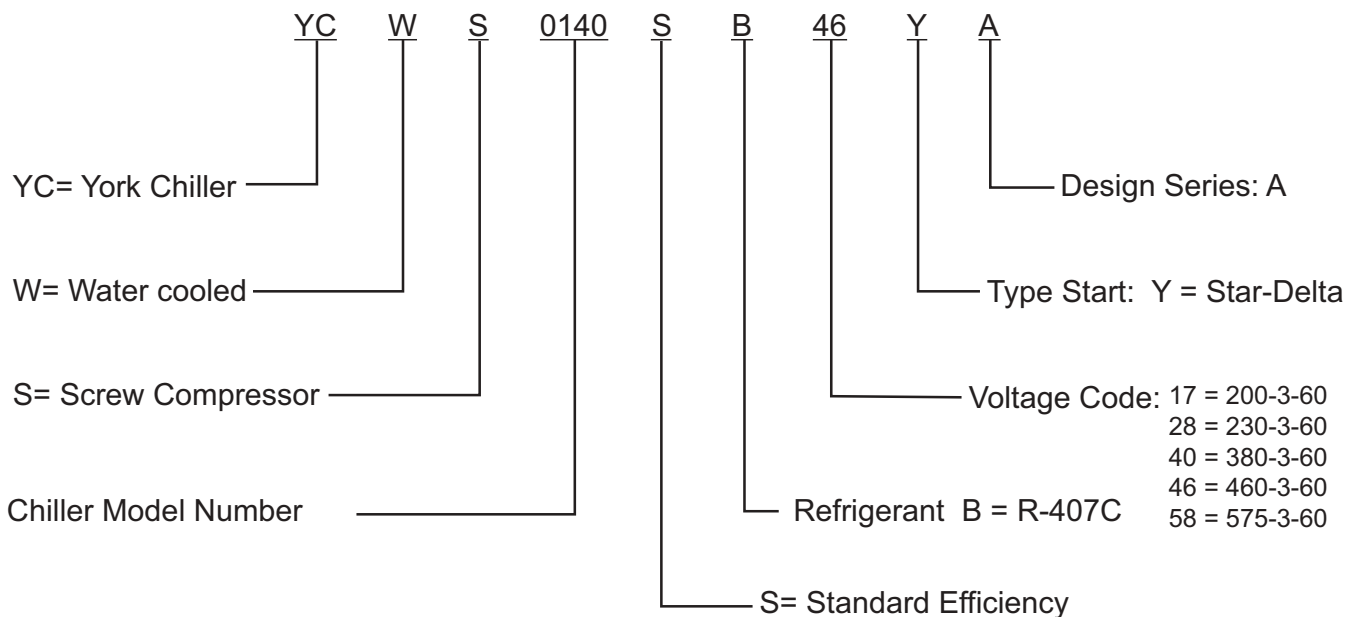

# Introduction

---

## York YCWS Water Cooled Screw Chillers



*YORK YCWS Water-Cooled models provide chilled water for all **HFC** air conditioning applications that use central station air handling or terminal units. They are completely self-contained and are designed for indoor (new or retrofit) installation. Each unit includes accessible semi-hermetic screw compressors, a liquid cooler, water cooled condenser, and a user-friendly, diagnostic Microcomputer Control Center all mounted on a rugged steel base. The units are produced at an ISO 9001 registered facility. The YCWS chillers have certified ratings in accordance with ARI Standard 550/590.*

# Specifications

---

## GENERAL

The Liquid Chiller will be completely assembled with all interconnecting refrigerant piping and internal wiring, ready for field installation. The unit can be covered with an optional coat of Caribbean Blue enamel.

There will be an operational test, with water flowing through the cooler, to check that each control device operates correctly. The chiller will be shipped with 10 lbs of HFC-407C refrigerant and York 'L' (POE) synthetic oil.

Units are designed in accordance with NFPA 70 (National Electric Code), U.L. and cU.L. Standards, ASHRAE/ANSI 15 Safety Code for Mechanical Refrigeration. All units are produced at an ISO 9001 registered facility. All YCWS chillers are rated and certified in accordance with ARI Standard 550/590 at ARI conditions.

## SEMI-HERMETIC YORK SCREW COMPRESSORS

- Continuous function, microprocessor controlled, 3- way proportional Capacity Control Valve provides regulated output pressure independent of valve input pressure for a stable, smooth, and precise match of compressor capacity to cooling load to 10% of chiller capacity.
- Automatic spring return of capacity control valve to minimum load position ensures compressor starting at minimum motor load. Internal discharge check to prevent rotor backspin upon shutdown.
- Acoustically tuned, internal discharge gas path eliminates objectionable noise at the source, while optimizing flow for maximum performance.
- Reliable suction gas cooled, high efficiency, accessible hermetic motor with APT2000 type magnet wire and redundant overload protection using both thermistor and current overload protection.
- Suction gas screen and serviceable, 0.5 micron full flow oil filter within the compressor housing.
- Cast iron compressor housing precisely machined for optimal clearances and superb efficiency. Entire compressor, from suction to discharge has a Design Working Pressure of 450psig (31 bar).
- 350W compressor body cartridge heater.

- Each compressor will be mounted on isolator pads to reduce transmission of vibration to the rest of the unit.

## COOLER

The dual-circuit cooler will be the direct-expansion type, with refrigerant in the tubes and chilled liquid flowing through the baffled shell. The design working pressure of the shell (liquid) side will be 150 PSIG (10.3 bar), and 300 PSIG (26.7 bar) for the tube (refrigerant) side.

The cooler will be constructed and tested in accordance with the applicable sections of the ASME Pressure Vessel Code, Section VIII, Division (1). The water side will be exempt per paragraph U-1, (c)(6).

The water baffles will be constructed of galvanized steel to resist corrosion. The removable heads will allow access to the internally enhanced, seamless, copper tubes. Vent and drain connections will be included.

The cooler will be covered with 3/4" (19.1 mm ) flexible, closed-cell, foam insulation (K = 0.25).

## CONDENSER

The condenser is a cleanable through-tube type with steel shell, copper tubes, removable water heads, and includes integral subcooling. Refer to PHYSICAL DATA for design working pressures. The shell will be constructed and tested in accordance with section VII, division 1 of the ASME pressure-vessel code. The water side is exempt per paragraph U-1 (c) of section VIII, division 1 of the ASME pressure-vessel code. The condenser is equipped with relief valves and will hold the full refrigerant charge for pumpdown.

## REFRIGERANT CIRCUIT

Two independent refrigerant circuits will be furnished on each unit. All piping will be copper with brazed joints. The liquid line will include: a shutoff valve with charging port; sightglass with moisture indicator; thermal expansion valve; solenoid valve; and high-absorption removable-core filter drier. The entire suction line and the liquid line between the expansion valve and the cooler will be insulated with flexible, closed-cell, foam insulation.

## POWER AND CONTROL PANELS

All controls and motor starting equipment necessary for unit operation shall be factory wired and function tested. The panel enclosures shall be designed to NEMA 1 (IP 32) and manufactured from powder-painted galvanized steel.

The Power and Control Panel shall be divided into a

power section for each electrical system, a common input section and a control section.

Each power panel shall contain:

Compressor starting contactors, control circuit serving compressor capacity control, compressor contactor coils and compressor motor overloads. The compressor motor overloads contain current transformers which sense each phase, as an input to the microprocessor, to protect the compressor motors from damage due to: low input current, high input current, unbalanced current, single phasing, phase reversal, and compressor locked rotor.

The common input section shall contain:

The control supply transformer providing 115V, customer relay board and control circuit switch disconnect/emergency stop device.

The control section shall contain:

On/Off rocker switch, microcomputer keypad and display, microprocessor board, I/O expansion board, relay boards, and 24V fused power supply board.

### MICROPROCESSOR CONTROLS

**Fuzzy Logic** control will be incorporated in the YCWS range of chillers. Fuzzy Logic allows the control system to monitor several key variables to provide tighter, more stable chilled water temperature control. The control system monitors the leaving chilled water temperature to track where it has been, where it is now, how fast it is moving, and accurately adjusts the chiller operation in anticipation of expected performance to minimize hunting and save energy.

The microprocessor shall have the following functions and displays:

- A liquid crystal 40 character display with text provided on two lines and light emitting diode backlighting for outdoor viewing.
- A color-coded, 35 button, sealed keypad with sections for Display, Entry, Setpoints, Clock, Print, Program, and Unit On/Off Switch.

The standard controls shall include: brine chilling or thermal storage, automatic pumpdown, run signal contacts, demand load limit from external building automation system input, remote reset liquid temperature reset input, unit alarm contacts, chilled liquid pump control, automatic reset after power failure, automatic system optimization

to match operating conditions, software stored in non-volatile memory (EPROM) to eliminate chiller failure due to AC power failure.

The microprocessor can be directly connected to a YORK ISN Building Automation System via the standard on-board RS485 communications port. This option also provides open system compatibility with other communications networks.

Programmed Setpoints shall be retained in a lithium battery backed RTC with a memory of five years.

**Display** - In Imperial (°F and PSIG) or SI (°C and BAR) units, and for each circuit:

- Return and leaving chilled liquid
- Day, date and time. Daily start/stop times. Holiday and Manual Override status.
- Compressor operating hours and starts. Automatic or manual lead/lag. Lead compressor identification.
- Run permissive status. No cooling load condition. Compressor run status.
- Anti-recycle timer and anti-coincident start timer status per compressor.
- Suction (and suction superheat), discharge, and oil pressures and temperatures per System.
- Percent full load compressor motor current per phase and average per phase. Compressor capacity control valve input steps.
- Cutout status and setpoints for: supply fluid temperature, low suction pressure, high discharge pressure and temperature, high oil temperature, low and high current, phase rotation safety, and low leaving liquid temperature.
- Unloading limit setpoints for high discharge pressure and compressor motor current.
- Liquid pulldown rate sensitivity (0.5°F to 5°F [0.3°C to 3.0°C]/minute in 0.1°F [0.05°C] increments).
- Status of: evaporator heater, load and unload timers, chilled water pump.
- Out of range message.
- Up to 6 fault shut down conditions.
- Standard Display Language is English, with an Option for Spanish.

**Entry** - Enter set point changes, cancel inputs, advance day, change AM/PM.

**Set Points** - Chilled liquid temperature, chilled liquid range, remote reset temperature range.

**Clock** - Time, daily or holiday start/stop schedule, manual override for servicing.

# Specifications (Continued)

---

**Print** - Operating data or system fault shutdown history for last six faults. Printouts through an RS-232 port via a separate printer (by others).

**Program** -

- Low leaving liquid temperature cutout, 300 to 600 second anti-recycle timer, lag compressor start time delay, and average motor current unload point. Liquid temperature setpoint reset signal from **YORK ISN** or building automation system (by others) via:
- Pulse width modulated (PWM) input for up to 40°F (22°C) total reset as standard.
- Optional Building Automation System interface input card for up to 20°F (11.1°C) reset using a: 4 to 20 mA, 0 to 10 Vdc input, or discrete reset input.
- NOTE: The Standard MicroPanel can be directly connected to a YORK ISN Building Automation System via the standard onboard RS485 communication port.

This Option also provides open system compatibility with other communications networks (BACnet™ & LONMARK™ via interface through standard onboard 485 or 232 port and an external YorkTalk Translator.

- Additional functions (password protected) for programming by a qualified service technician:

Cutouts for low suction pressure, high discharge pressure, high oil temperature.

Refrigerant type.

High discharge pressure unload setpoint.

Compressor motor current percent limit.

# Accessories & Options

## ELECTRICAL OPTIONS:

**MULTIPLE POINT POWER SUPPLY CONNECTION - Standard** field power wiring connection on all models is Multiple Point Power Connection to factory provided Terminal Blocks. Two field supplied electrical power circuits with appropriate branch circuit protection provide power to each of two motor control center cabinets, located on either side of the Control panel on the front of the chiller. Each cabinet contains starter elements for one compressor.

**Optional** to the Terminal Blocks for field power connection are Non-Fused Disconnects or Circuit Breaker Switches with external, lockable handles.

**SINGLE POINT POWER CONNECTION - (Factory Mounted)** An optional configuration for field connection of a single electrical circuit to: either Terminal Block or Non-Fused Disconnect Switch with lockable external handle (in compliance with Article 440 of N.E.C., to isolate unit power supply for service). Factory wiring is provided from the Terminal Block or Disconnect Switch to Factory supplied individual system Circuit Breakers, Non-Fused Disconnect switch with external, lockable handle or J Class Fuses/Fuse Block in each of the two compressor motor control centers. (Note: Single Point Non-Fused Disconnect Switch will not be supplied with individual system Non Fused Disconnect Switches with external, lockable handles in each of the two compressor motor control centers).

**65 Ka HIGH VOLTAGE PROTECTION - Non-Fused Disconnect Switch with fuses (200 & 575V) or Circuit Breakers (230, 380, & 460V)** are used for applications where customers have a requirement for single point wiring with high "fault current" withstanding capability. This option provides between 50Ka and 65Ka withstand protection to the equipment.

**BUILDING AUTOMATION SYSTEM INTERFACE (Factory Mounted)** – Provides means to reset the leaving chilled liquid temperature or percent full load amps (current limiting) from the BAS **(Factory Mounted)**:

- Printed circuit board to accept 4 to 20 milliamp, 0 to 10 VDC, or dry contact closure input from the BAS.
- A YORK ISN Building Automation System can provide a Pulse Width Modulated (PWM) signal direct to the standard control panel via the standard onboard RS485 port.

**FLOW SWITCH** – The flow switch or its equivalent must be furnished with each unit. 150 PSIG (10.5 bar) DWP – For standard units. Johnson Controls model F61MG-1C Vapor-proof SPDT, NEMA 4X switch (150 PSIG [10.5 bar] DWP), -20°F to 250°F- (29°C to 121°C), with 1" NPT connection for upright mounting in horizontal pipe. **(Field mounted)**

**DIFFERENTIAL PRESSURE SWITCH** - Alternative to the above mentioned Flow Switch. Pretemco Model DPS 300A-P4OPF-82582-S (20.7bar max working pressure). SPDT 5 amp 125/250 VAC switch. Range: 0 - 2.8bar, deadband: 0.003 - 0.005bar, with 1/4 NPT pressure connections.

**LANGUAGE LCD AND KEYPAD** - Standard display language and keypad is in English. Spanish is available as an option.

**PRINTER KIT** - Printer for obtaining printout of unit operating and history data. **(Field Mounted)**

**MULTIPLE UNIT SEQUENCE CONTROL (Field Mounted)** - Sequencing Control with automatic unit sequencing. Necessary items for operation and control of up to eight units with parallel water circuits. Includes software and mixed liquid temperature sensor (interconnecting wiring by others).

**PRESSURE VESSEL CODES** - Coolers and condensers can be supplied in conformance with the following pressure codes:  
A.S.M.E. **(Standard)**

**FINAL PAINT OVERSPRAY** - The unit can be sprayed with an optional coat of Caribbean Blue paint. **(Factory)**

**CHICAGO CODE RELIEF VALVES (Factory Mounted)** - Unit will be provided with relief valves to meet Chicago Code requirements.

**OPTIVIEW REMOTE CONTROL CENTER** - Graphically displays all operational and historical data, provides indoor control of unit setpoints and scheduling, and communicates with up to eight (8) chiller units from an indoor location. **(Field mounted)**

## ACCESSORIES:

**FLANGES (Weld Type)** – Consists of 150 PSI (10.5 bar) standard cooler (150 lb) R.F. flanges to convert to flanged cooler-connections and includes companion flanges. **(Field mounted)**

**FLANGES (Victaulic Type)** – Consists of (2) Flange adapter for grooved end pipe (standard 150 PSI [10.5 bar] cooler). Includes companion flanges. **(Field mounted)**

## VIBRATION ISOLATION:

- **Neoprene Isolators** – Recommended for normal installations. Provides very good performance in most applications for the least cost. **(Field mounted)**
- **1" Spring Isolators** – Level adjustable, spring and cage type isolators for mounting under the unit base rails. 1" nominal deflection may vary slightly by application. **(Field mounted)**
- **2" Seismic Spring Isolators** – Restrained Spring-

# Accessories & Options - Cont.

---

Flex Mountings incorporate a rugged welded steel housing with vertical and horizontal limit stops. Housings designed to withstand a minimum 1.0g accelerated force in all directions to 2". Level adjustable, deflection may vary slightly by application. (**Field-mounted**)

## **ALTERNATIVE CHILLED FLUID APPLICATIONS:**

**Standard** water chilling application range is 40°F to 50°F (4.4°C to 10°C) Leaving Chilled Water Temperature. To protect against nuisance safety trips below 40°F (4.4°C) and reduce the possibility of cooler damage due to freezing during chiller operation, the unit microprocessor automatically unloads the compressors at abnormally low suction temperature (pressure) conditions, prior to safety shutdown.

- **Process Brine Option** – Process or other applica-

tions requiring chilled fluid below 40°F (4.4°C) risk water freezing in the evaporator, typically overcome by using antifreeze. For these applications, the chiller system incorporates brine (ethylene or propylene glycol solution), and the system design Leaving Chilled Fluid Temperature must be provided on the order form to ensure proper factory configuration.

- **Thermal Storage Option** – Thermal Storage requires special capabilities from a chiller, including the ability to 'charge' an ice storage tank, then possibly automatically reset for operation at elevated Leaving Chilled Fluid Temperatures as required by automatic building controls. The Thermal Storage Option provides Ice Storage duty Leaving Chilled Fluid setpoints from 25°F to 15°F (-4°C to -10°C) minimum during charge cycle, with a Reset range of 36°F (20°C) supply fluid temperature.



Intentionally left blank

# Design Parameters

## English

YCWS	0100SB	0120SB	0140SB	0180SB	0200SB	0220SB	0240SB
Min. Cooler Water Flow - GPM	200	200	200	260	260	300	300
Max. Cooler Water Flow - GPM	506	506	506	695	695	830	830
Min. Cond. Water Flow - GPM	193	193	193	330	330	330	330
Max. Cond. Water Flow - GPM	645	645	645	1050	1050	1050	1050
Min. Lvg. Liquid Temp. - °F	40	40	40	40	40	40	40
Max. Lvg. Liquid Temp. - °F	50	50	50	50	50	50	50
Min. Ent. Cond. Water Temp - °F	75	75	75	75	75	75	75
Max. Ent. Cond. Water Temp - °F	95	95	95	95	95	95	95
Min. Equipment Room Temp. - °F	40	40	40	40	40	40	40
Max. Equipment Room Temp. - °F	115	115	115	115	115	115	115

## SI

YCWS	0100SB	0120SB	0140SB	0180SB	0200SB	0220SB	0240SB
Min. Cooler Water Flow - l/sec	12.6	12.6	12.6	16.4	16.4	18.9	18.9
Max. Cooler Water Flow - l/sec	31.9	31.9	31.9	43.8	43.8	52.4	52.4
Min. Cond. Water Flow - l/sec	12.2	12.2	12.2	20.8	20.8	20.8	20.8
Max. Cond. Water Flow - l/sec	40.7	40.7	40.7	66.2	66.2	66.2	66.2
Min. Lvg. Liquid Temp. - °C	4.4	4.4	4.4	4.4	4.4	4.4	4.4
Max. Lvg. Liquid Temp. - °C	10.0	10.0	10.0	10.0	10.0	10.0	10.0
Min. Ent. Cond. Water Temp - °C	23.8	23.8	23.8	23.8	23.8	23.8	23.8
Max. Ent. Cond. Water Temp - °C	35.0	35.0	35.0	35.0	35.0	35.0	35.0
Min. Equipment Room Temp. - °C	4.4	4.4	4.4	4.4	4.4	4.4	4.4
Max. Equipment Room Temp. - °C	46.1	46.1	46.1	46.1	46.1	46.1	46.1

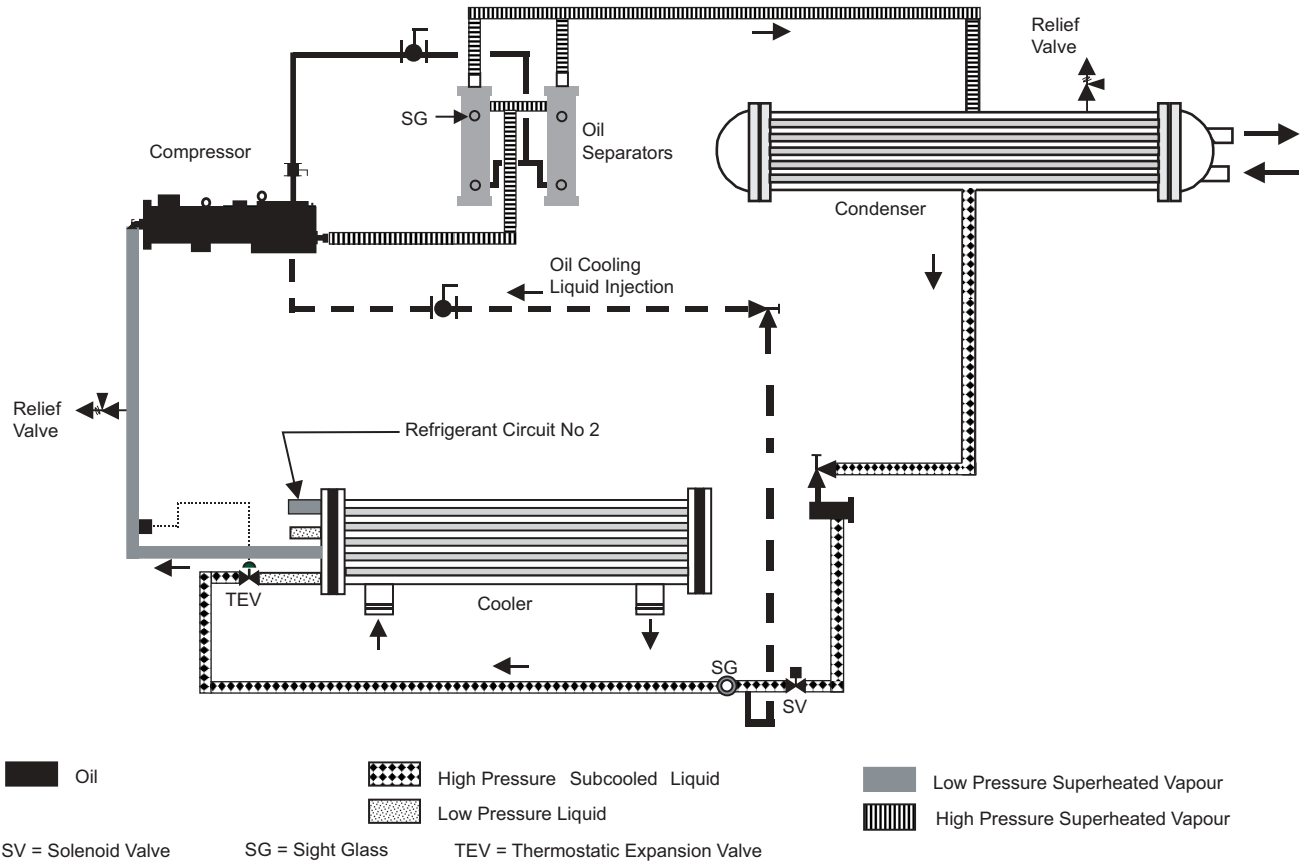

Low-pressure liquid refrigerant enters the cooler tubes and is evaporated and superheated by the heat energy absorbed from the chilled liquid passing through the cooler shell. Low-pressure vapor enters the compressor where pressure and superheat are increased. High-pressure vapor is passed through the oil separator where heat is rejected to the condenser water passing through the tubes. The fully condensed and subcooled liquid leaves the condenser and enters the expansion valve, where pressure reduction and further cooling take place. The low pressure liquid refrigerant then returns to the cooler. Each refrigerant circuit utilizes liquid injection, maintaining efficient oil temperature operation within the compressor.

# Pressure Drops

FIGURE 1 - COOLER WATER PRESSURE DROP CURVES (ENGLISH)

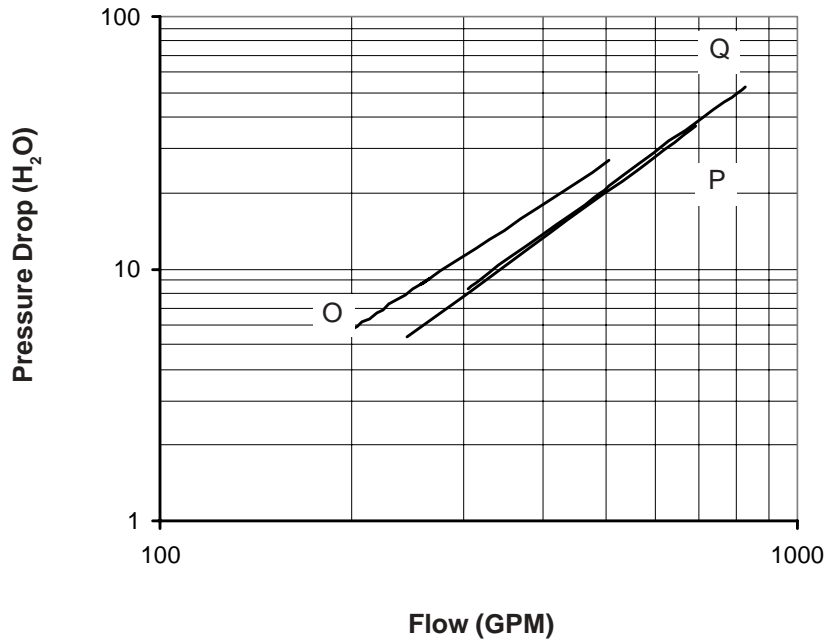

YCWS Model Number	Cooler
0100SB, 0120SB, 0140SB	O
0180SB, 0200SB	P
0220SB, 0240SB	Q

FIGURE 3 - CONDENSER WATER PRESSURE DROP CURVES (ENGLISH)

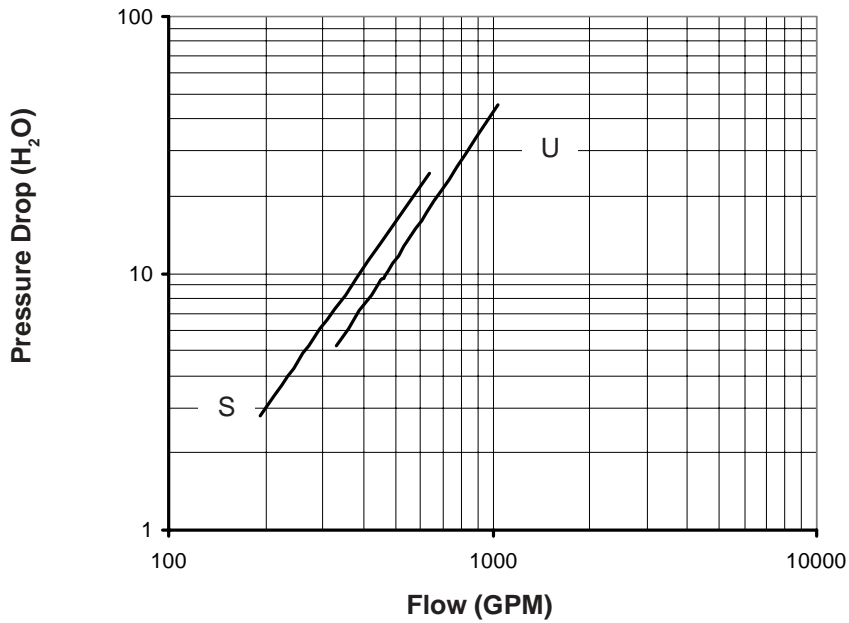

YCWS Model Number	Cooler
0100SB, 0120SB, 0140SB	S
0180SB, 0200SB 0220SB, 0240SB	U

**FIGURE 2 - COOLER WATER PRESSURE DROP CURVES (SI)**

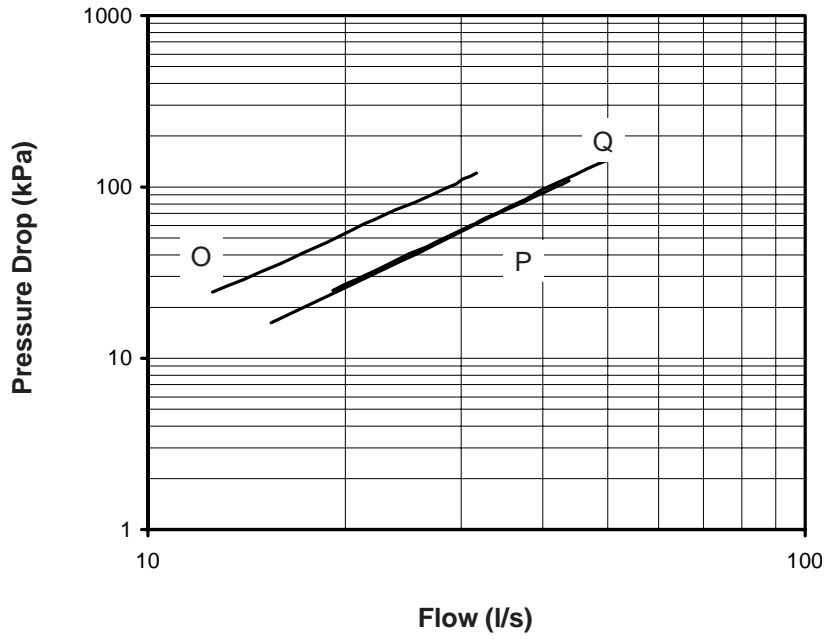

YCWS Model Number	Cooler
0100SB, 0120SB, 0140SB	O
0180SB, 0200SB	P
0220SB, 0240SB	Q

**FIGURE 4 - CONDENSER WATER PRESSURE DROP CURVES (SI)**

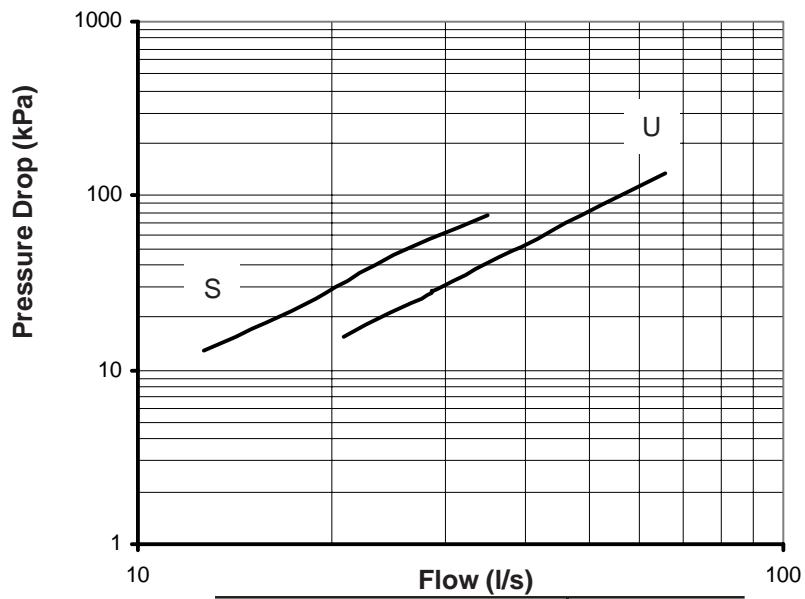

0100SB, 0120SB, 0140SB	S
0180SB, 0200SB	U
0220SB, 0240SB	U

# Selection Data

## GUIDE TO SELECTION

Complete water chilling capacity ratings for YORK YCWS chillers are shown on the following pages to cover the majority of job requirements. For any application beyond the scope of this Engineering Guide, consult your nearest YORK Office.

## SELECTION RULES

- RATINGS - YCWS 200, 230 380, 460 & 575-3-60** ratings are certified in accordance with ARI standard 550/590, at the ARI standard condition. Rating not at standard ARI conditions are rated in accordance with ARI rating procedures. These ratings may be interpolated but should not be extrapolated.
- COOLING WATER QUANTITY** - Ratings are based on 10°F chilled water range. Use the chilled water correction factors (below) for other ranges except as limited by water pressure drop, minimum or maximum water flows for the cooler.
- CONDENSER WATER QUANTITY** – Rating are applicable from 2 to 4 gpm/ton as limited by water pressure drop or minimum or maximum water flows for the condenser. Using the tabulated MBH, the Cond. GPM is calculated as follows:

$$\text{Cond. GPM} = \frac{\text{MBH} \times 2}{\text{Cond. Water Range (°F)}}$$

- FOULING FACTORS** – Rating are based on 0.0001 evaporator and 0.00025 condenser fouling factor. For other fouling factors, consult the table below or contact your YORK representative.

## EVAP FOULING FACTORS

Temp Split	0.0001		x	0.00025	
	Tons	Compr kW		Tons	Compr kW
6	0.9692	1.0015		0.9972	1.0001
8	0.9849	1.0008		0.9980	1.0001
10	1.0000	1.0000		0.9982	1.0001
12	1.0133	0.9993		0.9978	1.0001
14	1.0248	0.9986		0.9979	1.0001

Note: Temperature split factors @ 44°F Leaving Chilled Liquid Temp (LCLT)

## COND FOULING FACTORS

Temp Split	0.00025		x	0.0005	
	Tons	Compr kW		Tons	Compr kW
8	0.9998	1.0004		0.9957	1.0072
10	1.0000	1.0000		0.9959	1.0068
12	1.0001	0.9998		0.9961	1.0065
14	1.0001	0.9998		0.9965	1.0060

Note: Temperature split factors @ 95°F Leaving Condenser Water Temp (LCWT).

## METHOD OF SELECTION

If the duty requires a 10°F range on both the cooler and condenser, see “Ratings”. For water ranges other than 10°F, use the following procedure.

- Determine capacity required from the following formula

$$\text{Capacity (tons)} = \frac{\text{GPM} \times \text{Chilled Water Range (°F)}}{24}$$

- After applying any fouling factor corrections, the actual condenser heat rejection may be determined as follows:

$$\text{Heat Rejection (Btuh)} = (\text{Tons} \times 12,000) + (\text{kW} \times 3415)$$

$$\text{Heat Rejection (MBH)} = \frac{\text{Heat Rejection (Btuh)}}{1000}$$

$$= (\text{Tons} \times 12) + (\text{kW} \times 3.415)$$

- Determine condensing water requirements for water cooled models as follows:

$$\text{Condenser Tons} = \frac{\text{Heat Rejection (MBH)} \times 1000}{15,000}$$

$$\text{Cond. Water GPM} = \frac{\text{Condenser Tons} \times 30}{\text{Condenser Water Range (°F)}}$$

Or combine the two formulas:

$$\text{Cond. Water GPM} = \frac{\text{MBH} \times 2}{\text{Condenser Water Range (°F)}}$$

**SAMPLE SELECTION**

Water Cooled Condenser (YCWS)

GIVEN – Chill 200 GPM of water from 56°F to 44°F and 0.0001 evaporator fouling factor with 85°F to 95°F condensing water available. Fouling factor of 0.0005 special field for the condenser.

FIND – The required unit size capacity, kW, EER, and water pressure drop.

**SOLUTION:**

1. Chilled water range = 56°F - 44°F = 12°F and correction factors are 1.0133 for Tons and 0.9993 for kW for the cooler.

$$2. \text{ Capacity (tons)} = \frac{\text{GPM} \times \text{Chilled Water Range}}{24}$$

$$= \frac{200 \times 12}{24} = 100\text{TR}$$

2. From the rating, a model YCWS0120SB has a capacity range required. For the cooler leaving water temperature of 44°F and a condenser leaving water temperature of 95°F, the unit capacity rating table indicates:

$$\begin{aligned} \text{Tons} &= 106.2 \\ \text{KW} &= 96.7 \\ \text{EER} &= 13.2 \end{aligned}$$

Correcting for the 12°F chilled water range and the 0.0005 condenser-fouling factor:

$$\begin{aligned} \text{Tons} &= 106.2 \times 1.0133 \times 0.9961 = 107.2\text{TR} \\ \text{KW} &= 96.7 \times 0.9993 \times 1.0065 = 97.3 \end{aligned}$$

**The unit is suitable.**

3. Determine the average full load kW and EER at 95.0 Tons

$$\frac{95.0}{107.2} \times (97.3) = 86.2\text{KW}$$

$$\text{EER} = \frac{\text{Tons} \times 12}{\text{Kw}} = \frac{95.0 \times 12}{86.2} = 13.2$$

4. Determine the cond. Heat rejection as follows:

$$\begin{aligned} \text{Heat Rejection (MBH)} &= (\text{Tons} \times 12) + (\text{kW} \times 3.415) \\ &= (95.0 \times 12) + (86.2 \times 3.415) \\ &= 1140 + 294 \\ &= 1434 \end{aligned}$$

5. Determine GPM condensing water as follows:

$$\text{GPM Condenser Water} = \frac{\text{MBH} \times 2}{\text{Cond Water Range}}$$

6. From curves on pages 10 and 11, the pressure drops with 200GPM through the cooler and 288 through the condenser of the Model YCWS120SB

$$\begin{aligned} \text{Cooler Pressure Drop at 200 GPM} &= 2.9\text{ft} \\ \text{Condenser Pressure Drop at 288 GPM} &= 5.5\text{ft} \end{aligned}$$

# Ratings (HFC-407C English)

LCWT (°F)	LEAVING CONDENSER WATER TEMPERATURE (°F)															
	85.0				95.0				100.0				105.0			
	TONS	KW	MBH	EER	TONS	KW	MBH	EER	TONS	KW	MBH	EER	TONS	KW	MBH	EER

## YCWS0100SB

IPLV = 16.4

40.0	89.4	70.7	1314.0	15.2	81.2	80.4	1248.0	12.1	77.4	86.0	1222.0	10.8	73.7	92.2	1199.0	9.6
42.0	93.3	70.1	1359.0	16.0	84.8	79.7	1289.0	12.8	80.9	85.3	1261.0	11.4	77.1	91.4	1237.0	10.1
44.0	97.3	69.5	1405.0	16.8	88.5	79.0	1331.0	13.4	84.4	84.6	1301.0	12.0	80.5	90.6	1275.0	10.7
45.0	99.4	69.2	1428.0	17.2	90.4	78.7	1353.0	13.8	86.2	84.2	1321.0	12.3	82.2	90.2	1294.0	10.9
46.0	101.4	68.8	1451.0	17.7	92.3	78.3	1374.0	14.1	88.0	83.8	1342.0	12.6	84.0	89.7	1314.0	11.2
48.0	105.6	68.1	1499.0	18.6	96.1	77.6	1418.0	14.9	91.7	83.0	1384.0	13.3	87.6	88.9	1354.0	11.8
50.0	109.8	67.3	1547.0	19.6	100.1	76.8	1463.0	15.6	95.5	82.2	1427.0	13.9	91.2	88.1	1395.0	12.4

## YCWS0120SB

IPLV = 15.7

40.0	107.3	85.4	1578.0	15.1	97.6	97.4	1503.0	12.0	93.1	104.3	1472.0	10.7	88.8	111.7	1446.0	9.5
42.0	111.9	85.1	1633.0	15.8	101.9	97.1	1553.0	12.6	97.2	103.9	1520.0	11.2	92.7	111.3	1492.0	10.0
44.0	116.7	84.8	1689.0	16.5	106.2	96.7	1605.0	13.2	101.4	103.5	1570.0	11.8	96.8	110.8	1539.0	10.5
45.0	119.1	84.6	1717.0	16.9	108.5	96.5	1631.0	13.5	103.5	103.3	1595.0	12.0	98.8	110.6	1563.0	10.7
46.0	121.5	84.4	1746.0	17.3	110.7	96.3	1657.0	13.8	105.7	103.0	1620.0	12.3	100.9	110.3	1588.0	11.0
48.0	126.4	84.0	1803.0	18.1	115.3	95.8	1710.0	14.4	110.1	102.5	1671.0	12.9	105.2	109.8	1637.0	11.5
50.0	131.4	83.4	1862.0	18.9	119.9	95.3	1764.0	15.1	114.6	102.0	1723.0	13.5	109.5	109.2	1687.0	12.0

## YCWS0140SB

IPLV = 16.6

40.0	126.8	100.0	1863.0	15.2	115.4	114.4	1775.0	12.1	110.2	122.5	1740.0	10.8	105.1	131.3	1709.0	9.6
42.0	132.2	100.1	1928.0	15.8	120.5	114.4	1836.0	12.6	115.0	122.5	1798.0	11.3	109.8	131.3	1765.0	10.0
44.0	137.8	100.1	1994.0	16.5	125.6	114.4	1897.0	13.2	119.9	122.4	1857.0	11.8	114.5	131.1	1822.0	10.5
45.0	140.6	100.0	2028.0	16.9	128.2	114.3	1928.0	13.5	122.4	122.4	1887.0	12.0	117.0	131.0	1851.0	10.7
46.0	143.4	100.0	2062.0	17.2	130.9	114.2	1960.0	13.7	125.0	122.3	1917.0	12.3	119.4	130.9	1880.0	10.9
48.0	149.2	99.7	2130.0	17.9	136.2	114.0	2023.0	14.3	130.2	122.0	1978.0	12.8	124.4	130.6	1938.0	11.4
50.0	155.0	99.4	2199.0	18.7	141.7	113.7	2088.0	15.0	135.4	121.7	2040.0	13.4	129.5	130.3	1998.0	11.9

## YCWS0180SB

IPLV = 17.8

40.0	156.7	110.2	2257.0	17.1	142.2	126.1	2137.0	13.5	134.8	135.1	2079.0	12.0	129.1	144.9	2044.0	10.7
42.0	163.7	110.1	2339.0	17.8	148.5	126.0	2212.0	14.2	141.6	135.0	2159.0	12.6	134.4	144.7	2107.0	11.2
44.0	170.7	109.9	2423.0	18.6	155.1	125.7	2290.0	14.8	147.8	134.7	2233.0	13.2	141.0	144.4	2184.0	11.7
45.0	174.2	109.7	2465.0	19.1	158.4	125.5	2329.0	15.1	151.0	134.5	2271.0	13.5	144.0	144.2	2220.0	12.0
46.0	177.9	109.5	2509.0	19.5	161.7	125.4	2368.0	15.5	154.2	134.3	2309.0	13.8	147.1	143.9	2256.0	12.3
48.0	185.3	109.0	2595.0	20.4	168.5	124.9	2448.0	16.2	160.8	133.8	2386.0	14.4	153.4	143.4	2330.0	12.8
50.0	192.8	108.4	2684.0	21.4	175.5	124.3	2530.0	16.9	167.4	133.2	2464.0	15.1	159.8	142.9	2405.0	13.4

### NOTES:

1. Tons = Unit Cooling Capacity Output
2. kW = Compressor Input Power
3. MBH = Condenser heat rejection
4. EER = Chiller Energy Efficiency Ratio (Capacity [Tons x 12] ÷ kW)
5. LCWT = Leaving Chilled Water Temperature
6. Ratings based on 2.4 GPM cooler water per ton
7. Ratings certified in accordance with ARI Standard 550/590-98 up to 200 tons.



LCWT (°F)	LEAVING CONDENSER WATER TEMPERATURE (°F)															
	85.0				95.0				100.0				105.0			
	TONS	KW	MBH	EER	TONS	KW	MBH	EER	TONS	KW	MBH	EER	TONS	KW	MBH	EER

**YCWS0200SB****IPLV = 18.5**

40.0	177.4	124.7	2554.0	17.1	161.0	142.7	2419.0	13.5	153.4	152.9	2363.0	12.0	146.2	163.9	2313.0	10.7
42.0	185.2	124.6	2648.0	17.8	168.2	142.6	2505.0	14.2	160.3	152.7	2445.0	12.6	152.8	163.7	2392.0	11.2
44.0	193.2	124.4	2743.0	18.6	175.6	142.3	2593.0	14.8	167.4	152.5	2529.0	13.2	159.6	163.4	2473.0	11.7
45.0	197.3	124.2	2791.0	19.1	179.3	142.2	2637.0	15.1	171.0	152.3	2572.0	13.5	163.1	163.2	2514.0	12.0
46.0	201.4	124.0	2839.0	19.5	183.1	142.0	2682.0	15.5	174.6	152.1	2615.0	13.8	166.6	163.0	2555.0	12.3
48.0	209.7	123.5	2937.0	20.4	190.8	141.5	2772.0	16.2	182.0	151.6	2702.0	14.4	173.7	162.4	2639.0	12.8
50.0	218.1	122.8	3037.0	21.3	198.7	140.8	2865.0	16.9	189.6	150.9	2790.0	15.1	181.0	161.8	2724.0	13.4

**YCWS0220SB****IPLV = 17.6**

40.0	193.0	138.0	2787.0	16.8	175.3	157.9	2642.0	13.3	167.1	169.1	2582.0	11.9	159.2	181.3	2529.0	10.5
42.0	201.5	138.0	2889.0	17.5	183.0	157.8	2735.0	13.9	174.5	169.0	2671.0	12.4	166.4	181.1	2615.0	11.0
44.0	210.1	137.7	2992.0	18.3	191.0	157.5	2830.0	14.6	182.1	168.7	2761.0	13.0	173.8	180.8	2702.0	11.5
45.0	214.5	137.6	3044.0	18.7	195.1	157.4	2878.0	14.9	186.1	168.5	2808.0	13.2	177.5	180.6	2746.0	11.8
46.0	219.0	137.4	3096.0	19.1	199.2	157.2	2927.0	15.2	190.0	168.3	2855.0	13.5	181.2	180.4	2790.0	12.1
48.0	228.0	136.8	3202.0	20.0	207.6	156.6	3025.0	15.9	198.1	167.8	2949.0	14.2	189.0	179.8	2882.0	12.6
50.0	237.2	136.1	3311.0	20.9	216.1	156.0	3125.0	16.6	206.3	167.2	3046.0	14.8	196.9	179.2	2974.0	13.2

**YCWS0240SB****IPLV = 18.1**

40.0	210.9	151.5	3048.0	16.7	191.6	173.3	2891.0	13.3	182.6	185.6	2825.0	11.8	174.1	199.0	2768.0	10.5
42.0	220.2	151.5	3159.0	17.4	200.1	173.2	2992.0	13.9	190.8	185.5	2923.0	12.3	182.0	198.8	2862.0	11.0
44.0	229.6	151.3	3271.0	18.2	208.8	173.0	3096.0	14.5	199.2	185.2	3022.0	12.9	190.0	198.5	2957.0	11.5
45.0	234.3	151.1	3327.0	18.6	213.3	172.8	3149.0	14.8	203.4	185.1	3073.0	13.2	194.1	198.3	3006.0	11.7
46.0	239.1	150.9	3384.0	19.0	217.7	172.6	3202.0	15.1	207.7	184.8	3124.0	13.5	198.2	198.0	3055.0	12.0
48.0	248.9	150.3	3500.0	19.9	226.8	172.1	3309.0	15.8	216.5	184.3	3227.0	14.1	206.7	197.5	3154.0	12.6
50.0	258.9	149.6	3618.0	20.8	236.1	171.4	3418.0	16.5	225.5	183.7	3332.0	14.7	215.3	196.8	3255.0	13.1

**NOTES:**

1. Tons = Unit Cooling Capacity Output
2. kW = Compressor Input Power
3. MBH = Condenser heat rejection
4. EER = Chiller Energy Efficiency Ratio (Capacity [Tons x 12] ÷ kW)
5. LCWT = Leaving Chilled Water Temperature
6. Ratings based on 2.4 GPM cooler water per ton
7. Ratings certified in accordance with ARI Standard 550/590-98 up to 200 tons.

# Ratings (HFC-407C SI)

LCWT (°C)	LEAVING CONDENSER WATER TEMPERATURE (°C)															
	30.0				35.0				40.0				45.0			
	KW <sub>o</sub>	KW <sub>i</sub>	KW	COP	KW <sub>o</sub>	KW <sub>i</sub>	KW	COP	KW <sub>o</sub>	KW <sub>i</sub>	KW	COP	TONS	KW	MBH	EER

## YCWS0100SB

IPLV= 4.8 COP

5.0	314.9	71.5	386.0	4.4	288.7	80.3	369.0	3.6	264.7	90.9	355.0	2.9	242.8	103.1	346.0	2.4
6.0	327.3	70.9	398.0	4.6	300.2	79.7	380.0	3.8	275.4	90.1	365.0	3.1	252.8	102.2	355.0	2.5
7.0	340.0	70.4	410.0	4.8	312.0	79.1	391.0	4.0	286.4	89.4	375.0	3.2	263.1	101.3	364.0	2.6
8.0	352.8	69.8	422.0	5.1	324.0	78.4	402.0	4.1	297.6	88.7	386.0	3.4	273.5	100.5	374.0	2.7
9.0	365.9	69.1	435.0	5.3	336.2	77.8	414.0	4.3	309.0	87.9	396.0	3.5	284.2	99.6	383.0	2.9
10.0	379.3	68.4	447.0	5.5	348.6	77.1	425.0	4.5	320.6	87.2	407.0	3.7	295.0	98.8	393.0	3.0

## YCWS0120SB

IPLV= 4.6 COP

5.0	378.1	86.5	464.0	4.4	347.1	97.4	444.0	3.6	318.6	110.3	428.0	2.9	292.6	125.0	417.0	2.3
6.0	392.7	86.3	479.0	4.6	360.8	97.2	458.0	3.7	331.4	109.9	441.0	3.0	304.6	124.5	429.0	2.5
7.0	407.7	86.0	493.0	4.7	374.7	96.8	471.0	3.9	344.5	109.5	454.0	3.2	316.8	124.0	440.0	2.6
8.0	422.9	85.6	508.0	4.9	388.9	96.4	485.0	4.0	357.7	109.0	466.0	3.3	329.3	123.4	452.0	2.7
9.0	438.5	85.2	523.0	5.2	403.4	96.0	499.0	4.2	371.2	108.5	479.0	3.4	341.9	122.8	464.0	2.8
10.0	454.2	84.7	539.0	5.4	418.2	95.5	513.0	4.4	385.0	108.0	493.0	3.6	354.8	122.2	477.0	2.9

## YCWS0140SB

IPLV= 4.9 COP

5.0	447.1	101.5	548.0	4.4	410.8	114.6	525.0	3.6	377.5	129.7	507.0	2.9	347.0	147.0	494.0	2.4
6.0	464.2	101.6	565.0	4.6	426.8	114.6	541.0	3.7	392.5	129.6	522.0	3.0	361.1	146.8	508.0	2.5
7.0	481.7	101.5	583.0	4.7	443.2	114.5	557.0	3.9	407.8	129.5	537.0	3.2	375.4	146.6	522.0	2.6
8.0	499.5	101.4	601.0	4.9	459.8	114.4	574.0	4.0	423.4	129.3	552.0	3.3	390.0	146.3	536.0	2.7
9.0	517.7	101.2	618.0	5.1	476.7	114.2	590.0	4.2	439.2	129.1	568.0	3.4	404.9	146.0	551.0	2.8
10.0	536.2	100.9	637.0	5.3	494.1	113.9	608.0	4.3	455.4	128.8	584.0	3.5	420.1	145.7	565.0	2.9

## YCWS0180SB

IPLV= 5.2 COP

5.0	551.0	111.9	662.0	4.9	504.8	126.3	631.0	4.0	462.6	143.1	605.0	3.2	424.4	162.4	586.0	2.6
6.0	572.8	111.8	684.0	5.1	525.0	126.2	651.0	4.2	481.3	142.9	624.0	3.4	441.9	162.1	604.0	2.7
7.0	595.0	111.5	706.0	5.3	545.6	126.0	671.0	4.3	500.5	142.7	643.0	3.5	459.6	161.7	621.0	2.8
8.0	617.7	111.2	728.0	5.6	566.7	125.6	692.0	4.5	520.2	142.3	662.0	3.7	477.8	161.3	639.0	3.0
9.0	640.6	110.8	751.0	5.8	588.2	125.2	713.0	4.7	540.1	141.9	682.0	3.8	496.5	160.8	657.0	3.1
10.0	664.3	110.2	774.0	6.0	610.1	124.7	734.0	4.9	560.3	141.4	701.0	4.0	515.6	160.2	675.0	3.2

### NOTES:

1. KW<sub>o</sub> = Unit kW Cooling Capacity Output
2. KW<sub>i</sub> = Compressor kW Input
3. COP = Coefficient of Performance
4. LCWT= Leaving Chilled Water Temperature
5. Ratings based on 0.047 l/s cooler water per kW.

LCWT (°C)	LEAVING CONDENSER WATER TEMPERATURE (°C)															
	30.0				35.0				40.0				45.0			
	KWo	KWi	KW	COP	KWo	KWi	KW	COP	KWo	KWi	KW	COP	TONS	KW	MBH	EER

**YCWS0200SB****IPLV= 5.4 COP**

5.0	623.8	126.6	750.0	4.9	571.6	142.9	714.0	4.0	524.3	161.9	686.0	3.2	481.2	183.7	664.0	2.6
6.0	648.4	126.5	775.0	5.1	594.5	142.8	737.0	4.2	545.2	161.7	707.0	3.4	500.9	183.3	684.0	2.7
7.0	673.5	126.3	799.0	5.3	617.9	142.6	760.0	4.3	567.0	161.5	728.0	3.5	520.9	183.0	703.0	2.9
8.0	699.1	125.9	825.0	5.6	641.6	142.3	783.0	4.5	589.2	161.1	750.0	3.7	541.4	182.5	724.0	3.0
9.0	725.2	125.5	850.0	5.8	666.0	141.8	807.0	4.7	611.8	160.6	772.0	3.8	562.5	182.0	744.0	3.1
10.0	751.9	124.9	876.0	6.0	690.7	141.3	832.0	4.9	634.9	160.1	795.0	4.0	584.1	181.4	765.0	3.2

**YCWS0220SB****IPLV= 5.1 COP**

5.0	678.5	140.1	818.0	4.8	622.2	158.2	780.0	3.9	570.1	179.2	749.0	3.2	523.8	203.2	727.0	2.6
6.0	705.3	140.1	845.0	5.0	647.0	158.1	805.0	4.1	593.6	179.0	772.0	3.3	545.2	202.8	748.0	2.7
7.0	732.5	139.8	872.0	5.2	672.0	157.9	829.0	4.3	617.2	178.7	796.0	3.5	566.8	202.4	769.0	2.8
8.0	760.3	139.5	899.0	5.5	697.9	157.5	855.0	4.4	641.2	178.3	819.0	3.6	589.5	201.9	791.0	2.9
9.0	788.6	139.0	927.0	5.7	724.4	157.1	881.0	4.6	665.5	177.8	843.0	3.7	612.4	201.4	813.0	3.0
10.0	817.4	138.4	955.0	5.9	751.3	156.5	907.0	4.8	690.7	177.3	868.0	3.9	635.8	200.8	836.0	3.2

**YCWS0240SB****IPLV= 5.3 COP**

5.0	741.7	153.8	895.0	4.8	680.3	173.6	854.0	3.9	623.8	196.6	820.0	3.2	573.1	222.9	796.0	2.6
6.0	770.8	153.8	924.0	5.0	707.3	173.5	880.0	4.1	649.2	196.5	845.0	3.3	596.3	222.6	819.0	2.7
7.0	800.4	153.6	954.0	5.2	734.9	173.3	908.0	4.2	674.9	196.2	871.0	3.4	620.0	222.2	842.0	2.8
8.0	830.7	153.2	984.0	5.4	763.0	173.0	936.0	4.4	701.2	195.8	897.0	3.6	644.8	221.7	866.0	2.9
9.0	861.5	152.7	1014.0	5.6	791.8	172.5	964.0	4.6	727.9	195.3	923.0	3.7	669.8	221.1	891.0	3.0
10.0	892.7	152.1	1044.0	5.9	821.1	172.0	993.0	4.8	755.2	194.7	950.0	3.9	695.4	220.4	915.0	3.2

**NOTES:**

1. KWo = Unit kW Cooling Capacity Output
2. KWi= Compressor kW Input
3. COP = Coefficient of Performance
4. LCWT= Leaving Chilled Water Temperature
5. Ratings based on 0.047 l/s cooler water per kW.

# Ratings- Brine (30 % Ethylene Glycol) (R-22 English)

LCWT (°F)	LEAVING CONDENSER WATER TEMPERATURE (°F)											
	85.0				95.0				105.0			
	TONS	KW	MBH	EER	TONS	KW	MBH	EER	TONS	KW	MBH	EER

## YCWS0100SC

16.0	43.1	69.0	753.0	7.5	38.9	82.2	746.0	5.7	34.9	98.4	755.0	4.3
20.0	48.7	70.6	825.0	8.3	43.9	82.8	809.0	6.4	39.5	98.0	808.0	4.8
24.0	55.0	71.5	904.0	9.2	49.7	83.1	880.0	7.2	44.9	97.3	870.0	5.5
28.0	62.5	72.0	995.0	10.4	56.5	82.9	961.0	8.2	51.1	96.4	942.0	6.4
32.0	71.3	72.0	1101.0	11.9	64.6	82.4	1056.0	9.4	58.5	95.2	1026.0	7.4
36.0	81.0	71.6	1216.0	13.6	73.5	81.6	1161.0	10.8	66.7	93.9	1121.0	8.5
40.0	88.5	70.8	1303.0	15.0	80.5	80.5	1240.0	12.0	73.1	92.4	1193.0	9.5

## YCWS0120SC

16.0	52.0	77.9	890.0	8.0	47.0	92.6	879.0	6.1	42.3	110.4	884.0	4.6
20.0	58.7	80.6	979.0	8.7	53.0	94.6	958.0	6.7	47.8	111.6	954.0	5.1
24.0	66.3	82.6	1077.0	9.6	60.0	96.0	1047.0	7.5	54.2	112.3	1033.0	5.8
28.0	75.1	84.0	1188.0	10.7	68.0	96.9	1147.0	8.4	61.6	112.6	1123.0	6.6
32.0	85.5	85.0	1316.0	12.1	77.7	97.5	1264.0	9.6	70.4	112.7	1229.0	7.5
36.0	97.1	85.5	1456.0	13.6	88.3	97.7	1392.0	10.8	80.2	112.5	1346.0	8.6
40.0	106.0	85.4	1563.0	14.9	96.5	97.4	1490.0	11.9	87.8	111.8	1435.0	9.4

## YCWS0140SC

16.0	61.8	87.0	1038.0	8.5	55.8	103.3	1021.0	6.5	50.2	122.8	1021.0	4.9
20.0	69.6	90.7	1144.0	9.2	62.7	106.4	1116.0	7.1	56.8	125.4	1109.0	5.4
24.0	78.5	93.7	1262.0	10.1	71.1	109.1	1225.0	7.8	64.3	127.4	1206.0	6.1
28.0	88.9	96.1	1395.0	11.1	80.6	111.1	1346.0	8.7	73.0	129.0	1317.0	6.8
32.0	101.2	98.0	1548.0	12.4	91.9	112.7	1487.0	9.8	83.4	130.2	1445.0	7.7
36.0	114.7	99.3	1715.0	13.9	104.4	113.8	1641.0	11.0	94.9	131.1	1586.0	8.7
40.0	125.1	100.0	1842.0	15.0	114.0	114.3	1758.0	12.0	103.9	131.3	1694.0	9.5

## YCWS0180SC

16.0	75.7	97.6	1241.0	9.3	70.5	116.5	1243.0	7.3	61.4	137.0	1205.0	5.4
20.0	85.5	101.5	1372.0	10.1	77.1	118.9	1331.0	7.8	69.5	139.7	1311.0	6.0
24.0	96.0	104.5	1508.0	11.0	87.3	121.5	1462.0	8.6	78.8	141.8	1429.0	6.7
28.0	109.8	107.1	1683.0	12.3	100.0	123.7	1622.0	9.7	89.4	143.3	1562.0	7.5
32.0	125.3	108.8	1874.0	13.8	113.5	125.0	1788.0	10.9	102.7	144.4	1725.0	8.5
36.0	142.6	109.9	2086.0	15.6	129.2	125.9	1980.0	12.3	117.2	145.0	1901.0	9.7
40.0	155.9	110.2	2246.0	17.0	141.5	126.1	2128.0	13.5	128.4	144.9	2036.0	10.6

### NOTES:

1. Tons = Unit Cooling Capacity Output
2. kW = Compressor Input Power
3. MBH = Condenser heat rejection
4. EER = Chiller Energy Efficiency Ratio (Capacity [Tons x 12] ÷ kW)
5. LCWT = Leaving Chilled Water Temperature
6. Ratings based on 2.4 GPM cooler water per ton.
7. Rated in accordance with ARI Standard 550/590-98 up to 200 tons.
8. For ratings other than 30% glycol, refer to the Design 03 dxchill program.

LCWT (°F)	LEAVING CONDENSER WATER TEMPERATURE (°F)											
	85.0				95.0				105.0			
	TONS	KW	MBH	EER	TONS	KW	MBH	EER	TONS	KW	MBH	EER

**YCWS0200SC**

<b>16.0</b>	85.8	110.1	1406.0	9.4	77.4	130.4	1374.0	7.1	69.6	154.8	1364.0	5.4
<b>20.0</b>	96.7	114.5	1551.0	10.1	87.4	134.2	1507.0	7.8	78.8	157.9	1484.0	6.0
<b>24.0</b>	109.0	118.0	1710.0	11.1	98.9	137.3	1655.0	8.6	89.3	160.3	1618.0	6.7
<b>28.0</b>	124.4	121.0	1905.0	12.3	112.6	139.7	1827.0	9.7	101.5	162.0	1770.0	7.5
<b>32.0</b>	142.0	123.0	2123.0	13.8	128.5	141.3	2025.0	10.9	115.9	163.2	1948.0	8.5
<b>36.0</b>	161.4	124.3	2361.0	15.6	146.4	142.4	2243.0	12.3	132.8	164.0	2153.0	9.7
<b>40.0</b>	176.4	124.7	2542.0	17.0	160.2	142.7	2410.0	13.5	145.5	163.9	2306.0	10.7

**YCWS0220SC**

<b>16.0</b>	93.6	121.6	1538.0	9.2	84.4	144.0	1504.0	7.0	75.9	170.9	1494.0	5.3
<b>20.0</b>	105.7	126.7	1701.0	10.0	95.3	148.3	1649.0	7.7	85.9	174.3	1625.0	5.9
<b>24.0</b>	119.4	130.6	1878.0	11.0	107.8	151.7	1811.0	8.5	97.3	177.0	1772.0	6.6
<b>28.0</b>	135.4	133.7	2081.0	12.2	121.9	154.2	1989.0	9.5	110.6	179.0	1938.0	7.4
<b>32.0</b>	154.6	136.0	2319.0	13.6	139.9	156.3	2212.0	10.7	126.8	180.5	2137.0	8.4
<b>36.0</b>	175.7	137.5	2577.0	15.3	159.4	157.5	2450.0	12.1	144.6	181.3	2353.0	9.6
<b>40.0</b>	192.0	138.0	2774.0	16.7	174.4	157.9	2631.0	13.3	157.8	181.3	2513.0	10.4

**YCWS0240SC**

<b>16.0</b>	102.4	133.2	1683.0	9.2	92.3	157.7	1646.0	7.0	83.1	187.3	1636.0	5.3
<b>20.0</b>	114.9	138.4	1851.0	10.0	104.3	162.5	1806.0	7.7	94.0	191.0	1780.0	5.9
<b>24.0</b>	130.6	143.1	2055.0	10.9	117.8	166.2	1980.0	8.5	106.5	194.0	1940.0	6.6
<b>28.0</b>	148.1	146.6	2278.0	12.1	134.0	169.2	2185.0	9.5	121.1	196.3	2123.0	7.4
<b>32.0</b>	169.0	149.1	2536.0	13.6	153.1	171.4	2422.0	10.7	138.7	197.9	2340.0	8.4
<b>36.0</b>	191.9	150.8	2818.0	15.3	174.3	172.8	2681.0	12.1	158.1	198.9	2576.0	9.5
<b>40.0</b>	209.6	151.5	3032.0	16.6	190.6	173.3	2878.0	13.2	173.3	199.0	2758.0	10.4

**NOTES:**

1. Tons = Unit Cooling Capacity Output
2. kW = Compressor Input Power
3. MBH = Condenser heat rejection
4. EER = Chiller Energy Efficiency Ratio (Capacity [Tons x 12] ÷ kW)
5. LCWT = Leaving Chilled Water Temperature
6. Ratings based on 2.4 GPM cooler water per ton
7. Rated in accordance with ARI Standard 550/590-98 up to 200 tons.
8. For ratings other than 30% glycol, refer to the Design 03 dxchill program.

# Ratings- Brine (30 % Ethylene Glycol) (R-22 SI)

LCWT (°C)	LEAVING CONDENSER WATER TEMPERATURE (°C)											
	30.0				35.0				40.0			
	KW <sub>o</sub>	KW <sub>i</sub>	KW	COP	KW <sub>o</sub>	KW <sub>i</sub>	KW	COP	KW <sub>o</sub>	KW <sub>i</sub>	KW	COP

## YCWS0100SC

-8.0	157.5	70.9	228.0	2.2	143.4	82.5	225.0	1.7	130.4	96.6	227.0	1.4
-6.0	175.7	72.0	247.0	2.4	160.3	83.0	243.0	1.9	145.9	96.2	242.0	1.5
-4.0	196.5	72.7	269.0	2.7	179.4	83.0	262.0	2.2	163.6	95.6	259.0	1.7
-2.0	220.4	72.9	293.0	3.0	201.4	82.8	284.0	2.4	183.9	94.8	278.0	1.9
0.0	248.2	72.9	321.0	3.4	227.2	82.4	309.0	2.8	207.8	93.8	301.0	2.2
2.0	279.6	72.6	352.0	3.9	256.2	81.7	338.0	3.1	234.8	92.8	327.0	2.5
4.0	303.0	71.8	374.0	4.2	278.0	80.7	358.0	3.4	255.0	91.4	346.0	2.8

## YCWS0120SC

-8.0	190.0	80.4	270.0	2.4	173.3	93.5	266.0	1.9	157.8	109.1	266.0	1.5
-6.0	211.8	82.5	294.0	2.6	193.3	95.0	288.0	2.0	176.3	110.0	286.0	1.6
-4.0	236.5	84.1	320.0	2.8	216.1	96.2	312.0	2.3	197.4	110.6	308.0	1.8
-2.0	264.9	85.3	350.0	3.1	242.4	97.0	339.0	2.5	221.7	111.0	332.0	2.0
0.0	297.9	86.1	384.0	3.5	273.1	97.5	370.0	2.8	250.1	111.0	361.0	2.3
2.0	335.2	86.6	421.0	3.9	307.6	97.7	405.0	3.2	282.2	110.9	393.0	2.5
4.0	362.9	86.5	449.0	4.2	333.4	97.5	430.0	3.4	306.2	110.4	416.0	2.8

## YCWS0140SC

-8.0	225.5	90.0	315.0	2.5	205.8	104.6	310.0	2.0	187.4	121.8	309.0	1.5
-6.0	251.1	93.1	344.0	2.7	229.4	107.3	336.0	2.1	209.3	124.0	333.0	1.7
-4.0	280.1	95.6	375.0	2.9	256.3	109.5	365.0	2.3	234.2	125.8	360.0	1.9
-2.0	313.6	97.7	411.0	3.2	287.1	111.3	398.0	2.6	262.8	127.3	390.0	2.1
0.0	352.3	99.3	451.0	3.6	323.2	112.7	435.0	2.9	296.2	128.4	424.0	2.3
2.0	395.9	100.6	496.0	3.9	363.7	113.8	477.0	3.2	333.9	129.2	463.0	2.6
4.0	428.4	101.2	529.0	4.2	393.9	114.3	508.0	3.5	362.2	129.5	491.0	2.8

## YCWS0180SC

-8.0	276.6	100.8	377.0	2.7	252.0	116.9	368.0	2.2	229.4	135.9	365.0	1.7
-6.0	308.6	104.1	412.0	3.0	281.7	119.8	401.0	2.4	256.3	138.2	394.0	1.9
-4.0	343.1	106.6	449.0	3.2	314.8	122.0	436.0	2.6	287.1	140.0	427.0	2.1
-2.0	386.9	108.8	495.0	3.6	354.4	123.8	478.0	2.9	322.7	141.4	464.0	2.3
0.0	436.3	110.3	546.0	4.0	398.9	125.0	524.0	3.2	364.7	142.3	507.0	2.6
2.0	492.0	111.3	603.0	4.4	450.2	125.9	576.0	3.6	412.3	142.9	555.0	2.9
4.0	533.4	111.7	645.0	4.8	488.6	126.1	614.0	3.9	447.9	142.9	590.0	3.1

### NOTES:

1. KW<sub>o</sub> = Unit kW Cooling Capacity Output
2. KW<sub>i</sub> = Compressor kW Input
3. COP = Coefficient of Performance
4. LCWT= Leaving Chilled Water Temperature
5. Ratings based on 0.047 l/s cooler water per kW.
6. For ratings other than 30% glycol, refer to the Design 03 dxchill program.

LCWT (°C)	LEAVING CONDENSER WATER TEMPERATURE (°C)											
	30.0				35.0				40.0			
	KW <sub>o</sub>	KW <sub>i</sub>	KW	COP	KW <sub>o</sub>	KW <sub>i</sub>	KW	COP	KW <sub>o</sub>	KW <sub>i</sub>	KW	COP

**YCWS0200SC**

-8.0	313.6	113.8	427.0	2.8	285.6	132.0	417.0	2.2	259.9	153.5	413.0	1.7
-6.0	349.7	117.5	467.0	3.0	319.0	135.2	454.0	2.4	290.5	156.1	446.0	1.9
-4.0	387.5	120.3	507.0	3.2	356.5	137.8	494.0	2.6	325.5	158.2	483.0	2.1
-2.0	438.6	122.9	561.0	3.6	400.0	139.8	539.0	2.9	365.1	159.7	524.0	2.3
0.0	494.3	124.7	619.0	4.0	451.9	141.3	593.0	3.2	412.7	160.9	573.0	2.6
2.0	557.1	125.9	683.0	4.4	510.1	142.4	652.0	3.6	467.3	161.6	629.0	2.9
4.0	603.7	126.3	730.0	4.8	553.5	142.7	696.0	3.9	507.4	161.7	669.0	3.1

**YCWS0220SC**

-8.0	341.6	125.7	467.0	2.7	311.4	145.8	457.0	2.1	283.4	169.5	453.0	1.7
-6.0	381.1	129.9	511.0	2.9	347.6	149.4	497.0	2.3	316.6	172.4	489.0	1.8
-4.0	424.2	133.1	557.0	3.2	387.9	152.2	540.0	2.6	354.6	174.8	529.0	2.0
-2.0	477.6	135.9	613.0	3.5	436.4	154.6	591.0	2.8	395.4	176.4	572.0	2.2
0.0	533.9	137.7	671.0	3.9	489.6	156.2	645.0	3.1	450.6	177.9	628.0	2.5
2.0	606.2	139.3	745.0	4.4	555.3	157.5	712.0	3.5	508.6	178.7	687.0	2.9
4.0	657.0	139.8	796.0	4.7	602.4	157.9	760.0	3.8	552.5	178.9	731.0	3.1

**YCWS0240SC**

-8.0	373.8	137.7	511.0	2.7	340.8	159.7	500.0	2.1	310.2	185.7	496.0	1.7
-6.0	415.7	142.1	557.0	2.9	380.2	163.7	543.0	2.3	346.6	189.0	535.0	1.8
-4.0	466.0	146.0	612.0	3.2	425.4	166.9	592.0	2.6	387.9	191.5	579.0	2.0
-2.0	522.4	148.9	671.0	3.5	477.4	169.4	646.0	2.8	436.2	193.6	629.0	2.3
0.0	588.4	151.2	739.0	3.9	538.3	171.4	709.0	3.1	492.5	195.0	687.0	2.5
2.0	662.5	152.8	815.0	4.3	607.2	172.7	780.0	3.5	556.3	196.1	752.0	2.8
4.0	717.5	153.4	871.0	4.7	658.5	173.2	831.0	3.8	604.2	196.3	800.0	3.1

**NOTES:**

1. KW<sub>o</sub> = Unit kW Cooling Capacity Output
2. KW<sub>i</sub> = Compressor kW Input
3. COP = Coefficient of Performance
4. LCWT = Leaving Chilled Water Temperature
5. Ratings based on 0.047 l/s cooler water per kW.
6. For ratings other than 30% glycol, refer to the Design 03 dxchill program.

# Ratings- Brine (30 % Propylene Glycol) (R-22 English)

LCWT (°F)	LEAVING CONDENSER WATER TEMPERATURE (°F)											
	85.0				95.0				105.0			
	TONS	KW	MBH	EER	TONS	KW	MBH	EER	TONS	KW	MBH	EER

## YCWS0100SC

16.0	42.9	68.9	750.0	7.5	38.7	82.1	744.0	5.6	34.8	98.4	753.0	4.2
20.0	48.4	70.5	821.0	8.2	43.7	82.8	807.0	6.3	39.4	98.0	807.0	4.8
24.0	54.7	71.5	900.0	9.2	49.5	83.1	877.0	7.1	44.7	97.4	868.0	5.5
28.0	62.1	71.9	990.0	10.4	56.2	82.9	957.0	8.1	50.8	96.4	939.0	6.3
32.0	70.8	72.0	1095.0	11.8	64.2	82.4	1052.0	9.3	58.2	95.3	1023.0	7.3
36.0	80.5	71.6	1210.0	13.5	73.1	81.7	1156.0	10.7	66.4	94.0	1117.0	8.5
40.0	87.9	70.8	1297.0	14.9	80.0	80.6	1234.0	11.9	72.7	92.5	1188.0	9.4

## YCWS0120SC

16.0	42.9	68.9	750.0	7.5	38.7	82.1	744.0	5.6	34.8	98.4	753.0	4.2
20.0	48.4	70.5	821.0	8.2	43.7	82.8	807.0	6.3	39.4	98.0	807.0	4.8
24.0	54.7	71.5	900.0	9.2	49.5	83.1	877.0	7.1	44.7	97.4	868.0	5.5
28.0	62.1	71.9	990.0	10.4	56.2	82.9	957.0	8.1	50.8	96.4	939.0	6.3
32.0	70.8	72.0	1095.0	11.8	64.2	82.4	1052.0	9.3	58.2	95.3	1023.0	7.3
36.0	80.5	71.6	1210.0	13.5	73.1	81.7	1156.0	10.7	66.4	94.0	1117.0	8.5
40.0	87.9	70.8	1297.0	14.9	80.0	80.6	1234.0	11.9	72.7	92.5	1188.0	9.4

## YCWS0140SC

16.0	61.3	86.7	1031.0	8.5	55.4	103.0	1016.0	6.4	49.9	122.6	1017.0	4.9
20.0	69.0	90.4	1136.0	9.2	62.4	106.2	1111.0	7.0	56.4	125.2	1104.0	5.4
24.0	77.9	93.5	1253.0	10.0	70.5	108.9	1218.0	7.8	63.8	127.3	1200.0	6.0
28.0	88.1	95.9	1384.0	11.0	80.0	111.0	1338.0	8.6	72.5	128.9	1310.0	6.7
32.0	100.2	97.8	1537.0	12.3	91.1	112.6	1478.0	9.7	82.8	130.2	1438.0	7.6
36.0	113.7	99.2	1702.0	13.7	103.5	113.8	1630.0	10.9	94.2	131.0	1577.0	8.6
40.0	124.1	99.9	1829.0	14.9	113.1	114.3	1747.0	11.9	103.1	131.3	1685.0	9.4

## YCWS0180SC

16.0	75.4	97.4	1237.0	9.3	68.0	115.3	1209.0	7.1	61.1	136.9	1200.0	5.4
20.0	85.1	101.4	1368.0	10.1	77.0	118.8	1329.0	7.8	69.2	139.7	1307.0	5.9
24.0	96.3	104.6	1513.0	11.1	87.0	121.5	1458.0	8.6	78.5	141.8	1425.0	6.6
28.0	109.4	107.0	1678.0	12.3	98.9	123.5	1608.0	9.6	89.4	143.3	1562.0	7.5
32.0	124.9	108.8	1870.0	13.8	113.1	125.0	1783.0	10.9	102.3	144.4	1721.0	8.5
36.0	142.1	109.9	2080.0	15.5	128.8	125.9	1975.0	12.3	116.7	145.0	1895.0	9.7
40.0	155.3	110.2	2240.0	16.9	141.0	126.1	2123.0	13.4	127.8	144.9	2028.0	10.6

### NOTES:

1. Tons = Unit Cooling Capacity Output
2. kW = Compressor Input Power
3. MBH = Condenser heat rejection
4. EER = Chiller Energy Efficiency Ratio (Capacity [Tons x 12] ÷ kW)
5. LCWT = Leaving Chilled Water Temperature
6. Ratings based on 2.4 GPM cooler water per ton
7. Rated in accordance with ARI Standard 550/590-98 up to 200 tons.
8. For ratings other than 30% glycol, refer to the Design 03 dxchill program.



LCWT (°F)	LEAVING CONDENSER WATER TEMPERATURE (°F)											
	85.0				95.0				105.0			
	TONS	KW	MBH	EER	TONS	KW	MBH	EER	TONS	KW	MBH	EER

**YCWS0200SC**

<b>16.0</b>	85.5	109.9	1401.0	9.3	77.0	130.2	1368.0	7.1	69.3	154.7	1359.0	5.4
<b>20.0</b>	96.7	114.5	1551.0	10.1	87.0	134.1	1502.0	7.8	78.5	157.8	1481.0	6.0
<b>24.0</b>	109.2	118.1	1713.0	11.1	98.6	137.2	1651.0	8.6	89.0	160.2	1614.0	6.7
<b>28.0</b>	123.9	120.9	1900.0	12.3	112.1	139.6	1821.0	9.6	101.3	162.0	1768.0	7.5
<b>32.0</b>	141.4	122.9	2116.0	13.8	128.1	141.3	2020.0	10.9	116.0	163.2	1949.0	8.5
<b>36.0</b>	160.8	124.3	2353.0	15.5	145.9	142.4	2237.0	12.3	132.4	164.0	2148.0	9.7
<b>40.0</b>	175.6	124.7	2533.0	16.9	159.7	142.7	2403.0	13.4	145.1	163.9	2300.0	10.6

**YCWS0220SC**

<b>16.0</b>	93.2	121.4	1532.0	9.2	84.0	143.8	1498.0	7.0	75.6	170.7	1489.0	5.3
<b>20.0</b>	105.2	126.5	1693.0	10.0	94.2	147.9	1635.0	7.6	85.5	174.2	1621.0	5.9
<b>24.0</b>	118.9	130.5	1873.0	10.9	107.4	151.6	1806.0	8.5	97.0	176.9	1767.0	6.6
<b>28.0</b>	135.0	133.6	2076.0	12.1	122.1	154.3	1991.0	9.5	110.4	179.0	1935.0	7.4
<b>32.0</b>	154.0	136.0	2312.0	13.6	139.5	156.2	2207.0	10.7	126.4	180.4	2132.0	8.4
<b>36.0</b>	175.0	137.5	2569.0	15.3	158.9	157.5	2444.0	12.1	144.2	181.3	2349.0	9.5
<b>40.0</b>	191.2	138.0	2765.0	16.6	173.8	157.9	2624.0	13.2	158.0	181.3	2514.0	10.5

**YCWS0240SC**

<b>16.0</b>	102.0	133.0	1678.0	9.2	91.9	157.5	1641.0	7.0	82.7	187.1	1631.0	5.3
<b>20.0</b>	115.1	138.5	1854.0	10.0	103.9	162.3	1801.0	7.7	93.6	190.9	1774.0	5.9
<b>24.0</b>	130.1	143.0	2049.0	10.9	117.5	166.1	1977.0	8.5	106.1	193.9	1935.0	6.6
<b>28.0</b>	147.6	146.5	2271.0	12.1	133.6	169.1	2180.0	9.5	120.4	196.2	2115.0	7.4
<b>32.0</b>	168.3	149.1	2528.0	13.5	152.6	171.3	2415.0	10.7	138.3	197.9	2334.0	8.4
<b>36.0</b>	191.1	150.8	2807.0	15.2	173.6	172.8	2673.0	12.1	157.6	198.9	2570.0	9.5
<b>40.0</b>	208.6	151.5	3020.0	16.5	189.8	173.2	2869.0	13.1	172.7	199.0	2751.0	10.4

**NOTES:**

1. Tons = Unit Cooling Capacity Output
2. kW = Compressor Input Power
3. MBH = Condenser heat rejection
4. EER = Chiller Energy Efficiency Ratio (Capacity [Tons x 12] ÷ kW)
5. LCWT = Leaving Chilled Water Temperature
6. Ratings based on 2.4 GPM cooler water per ton
7. Rated in accordance with ARI Standard 550/590-98 up to 200 tons.
8. For ratings other than 30% glycol, refer to the Design 03 dxchill program.

# Ratings- Brine (30 % Propylene Glycol) (R-22 SI)

LCWT (°C)	LEAVING CONDENSER WATER TEMPERATURE (°C)											
	30.0				35.0				40.0			
	KW <sub>o</sub>	KW <sub>i</sub>	KW	COP	KW <sub>o</sub>	KW <sub>i</sub>	KW	COP	KW <sub>o</sub>	KW <sub>i</sub>	KW	COP

## YCWS0100SC

-8.0	156.6	70.8	227.0	2.2	142.8	82.5	225.0	1.7	129.8	96.6	226.0	1.3
-6.0	174.8	71.9	246.0	2.4	159.4	82.9	242.0	1.9	145.2	96.2	241.0	1.5
-4.0	195.3	72.6	268.0	2.7	178.4	83.1	261.0	2.2	162.8	95.7	258.0	1.7
-2.0	219.0	72.9	291.0	3.0	200.2	82.9	283.0	2.4	183.0	94.9	277.0	1.9
0.0	246.6	72.9	319.0	3.4	225.8	82.4	308.0	2.7	206.7	93.9	300.0	2.2
2.0	277.8	72.6	350.0	3.8	254.7	81.8	336.0	3.1	233.4	92.8	326.0	2.5
4.0	301.0	71.9	372.0	4.2	276.3	80.8	357.0	3.4	253.6	91.5	345.0	2.8

## YCWS0120SC

-8.0	188.7	80.2	268.0	2.4	172.1	93.3	265.0	1.8	156.7	109.0	265.0	1.4
-6.0	210.2	82.3	292.0	2.6	192.0	94.9	287.0	2.0	175.1	109.9	285.0	1.6
-4.0	234.7	84.0	318.0	2.8	214.6	96.1	310.0	2.2	196.1	110.6	306.0	1.8
-2.0	262.8	85.2	348.0	3.1	240.6	97.0	337.0	2.5	220.2	110.9	331.0	2.0
0.0	295.6	86.0	381.0	3.4	271.0	97.5	368.0	2.8	248.3	111.0	359.0	2.2
2.0	332.5	86.5	419.0	3.8	305.2	97.7	403.0	3.1	280.2	110.9	391.0	2.5
4.0	360.1	86.5	446.0	4.2	330.9	97.5	428.0	3.4	304.1	110.4	414.0	2.8

## YCWS0140SC

-8.0	223.6	89.7	313.0	2.5	204.2	104.4	308.0	2.0	186.1	121.7	307.0	1.5
-6.0	249.0	92.8	341.0	2.7	227.6	107.1	334.0	2.1	207.8	123.9	331.0	1.7
-4.0	277.8	95.4	373.0	2.9	254.2	109.3	363.0	2.3	232.4	125.7	358.0	1.9
-2.0	310.8	97.5	408.0	3.2	284.8	111.2	396.0	2.6	260.8	127.2	388.0	2.1
0.0	349.2	99.2	448.0	3.5	320.4	112.6	433.0	2.9	293.9	128.3	422.0	2.3
2.0	392.4	100.5	492.0	3.9	360.6	113.7	474.0	3.2	331.3	129.1	460.0	2.6
4.0	424.8	101.1	526.0	4.2	390.7	114.2	505.0	3.4	359.4	129.4	488.0	2.8

## YCWS0180SC

-8.0	275.5	100.7	376.0	2.7	250.9	116.8	367.0	2.2	228.2	135.8	364.0	1.7
-6.0	307.5	104.0	411.0	3.0	280.2	119.6	399.0	2.3	255.2	138.1	393.0	1.9
-4.0	343.8	106.7	450.0	3.2	313.7	121.9	435.0	2.6	286.1	139.9	426.0	2.0
-2.0	386.2	108.8	495.0	3.6	352.2	123.7	476.0	2.9	321.7	141.3	463.0	2.3
0.0	434.8	110.3	545.0	3.9	397.6	125.0	522.0	3.2	363.4	142.3	505.0	2.6
2.0	490.2	111.3	601.0	4.4	448.9	125.9	574.0	3.6	410.9	142.9	553.0	2.9
4.0	531.5	111.7	643.0	4.8	487.2	126.1	613.0	3.9	446.5	142.9	589.0	3.1

### NOTES:

1. KW<sub>o</sub> = Unit kW Cooling Capacity Output
2. KW<sub>i</sub> = Compressor kW Input
3. COP = Coefficient of Performance
4. LCWT= Leaving Chilled Water Temperature
5. Ratings based on 0.047 l/s cooler water per kW.
6. For ratings other than 30% glycol, refer to the Design 03 dxchill program.

LCWT (°C)	LEAVING CONDENSER WATER TEMPERATURE (°C)											
	30.0				35.0				40.0			
	KWo	KWi	KW	COP	KWo	KWi	KW	COP	KWo	KWi	KW	COP

**YCWS0200SC**

<b>-8.0</b>	312.2	113.7	425.0	2.8	284.3	131.8	416.0	2.2	258.6	153.4	412.0	1.7
<b>-6.0</b>	348.5	117.4	465.0	3.0	317.8	135.1	453.0	2.4	289.2	156.0	445.0	1.9
<b>-4.0</b>	389.6	120.5	510.0	3.2	355.5	137.7	493.0	2.6	324.2	158.1	482.0	2.1
<b>-2.0</b>	437.1	122.8	560.0	3.6	400.5	139.8	540.0	2.9	364.6	159.7	524.0	2.3
<b>0.0</b>	492.4	124.6	617.0	4.0	450.5	141.3	591.0	3.2	412.0	160.9	572.0	2.6
<b>2.0</b>	554.8	125.8	680.0	4.4	508.3	142.3	650.0	3.6	465.5	161.6	627.0	2.9
<b>4.0</b>	601.2	126.3	727.0	4.8	551.5	142.7	694.0	3.9	505.8	161.7	667.0	3.1

**YCWS0220SC**

<b>-8.0</b>	340.3	125.5	465.0	2.7	310.4	145.7	456.0	2.1	282.1	169.4	451.0	1.7
<b>-6.0</b>	379.6	129.7	509.0	2.9	346.2	149.2	495.0	2.3	315.3	172.3	487.0	1.8
<b>-4.0</b>	424.5	133.1	557.0	3.2	387.4	152.2	539.0	2.6	353.4	174.7	528.0	2.0
<b>-2.0</b>	476.0	135.8	611.0	3.5	435.0	154.5	589.0	2.8	396.6	176.5	573.0	2.3
<b>0.0</b>	536.2	137.8	674.0	3.9	490.5	156.2	646.0	3.1	448.2	177.8	626.0	2.5
<b>2.0</b>	603.9	139.2	743.0	4.3	553.5	157.4	711.0	3.5	507.1	178.7	685.0	2.8
<b>4.0</b>	654.3	139.8	794.0	4.7	600.4	157.9	758.0	3.8	550.7	178.9	729.0	3.1

**YCWS0240SC**

<b>-8.0</b>	373.2	137.6	510.0	2.7	339.4	159.5	499.0	2.1	308.7	185.6	494.0	1.7
<b>-6.0</b>	415.5	142.1	557.0	2.9	379.2	163.6	542.0	2.3	345.2	188.8	534.0	1.8
<b>-4.0</b>	464.4	145.9	610.0	3.2	423.9	166.8	590.0	2.5	386.3	191.4	577.0	2.0
<b>-2.0</b>	520.5	148.8	669.0	3.5	475.9	169.4	645.0	2.8	434.9	193.5	628.0	2.3
<b>0.0</b>	586.0	151.1	737.0	3.9	536.5	171.3	707.0	3.1	491.0	195.0	686.0	2.5
<b>2.0</b>	659.5	152.7	812.0	4.3	604.9	172.7	777.0	3.5	554.5	196.0	750.0	2.8
<b>4.0</b>	714.2	153.4	867.0	4.7	655.9	173.2	829.0	3.8	602.1	196.3	798.0	3.1

**NOTES:**

1. KW<sub>o</sub> = Unit kW Cooling Capacity Output
2. KW<sub>i</sub> = Compressor kW Input
3. COP = Coefficient of Performance
4. LCWT = Leaving Chilled Water Temperature
5. Ratings based on 0.047 l/s cooler water per kW.
8. For ratings other than 30% glycol, refer to the Design 03 dxchill program.

# Brine Correction Factors

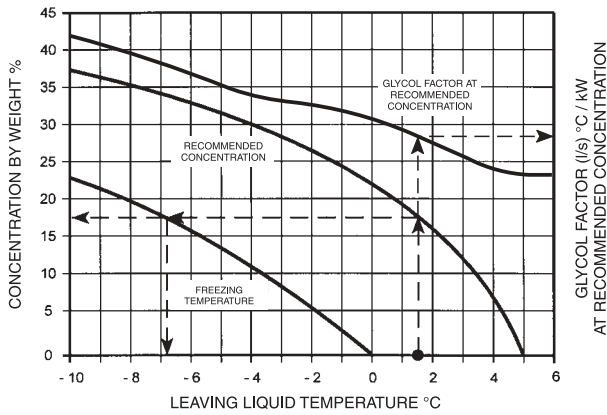

**FIGURE 3 - RECOMMENDED CONCENTRATIONS FOR ETHYLENE GLYCOL SOLUTIONS**

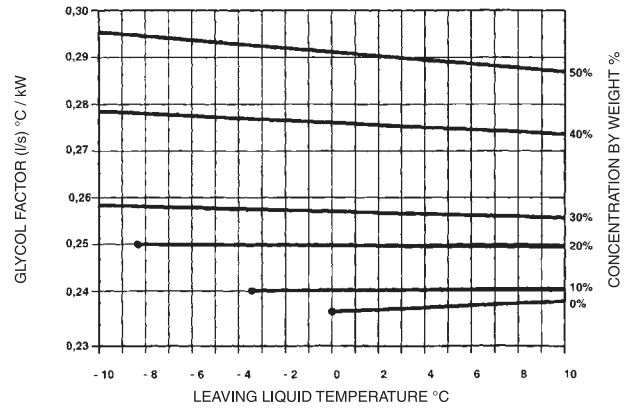

**FIGURE 4 - FACTORS AT OTHER CONCENTRATIONS FOR ETHYLENE GLYCOL SOLUTIONS**

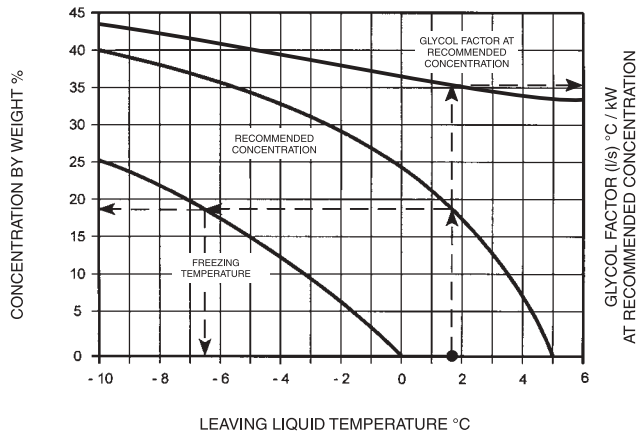

**FIGURE 5 - RECOMMENDED CONCENTRATIONS FOR PROPYLENE GLYCOL SOLUTIONS**

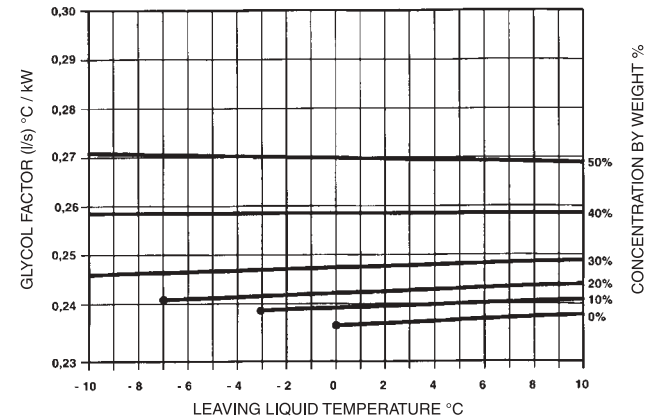

**FIGURE 6 - FACTORS AT OTHER CONCENTRATIONS FOR PROPYLENE GLYCOL SOLUTIONS**

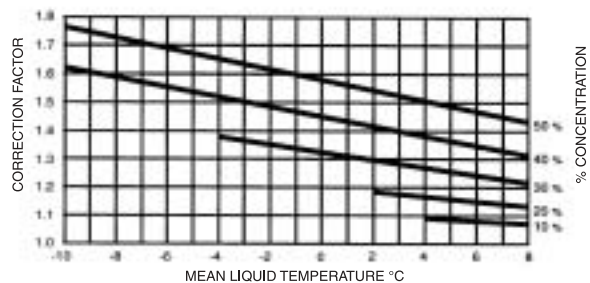
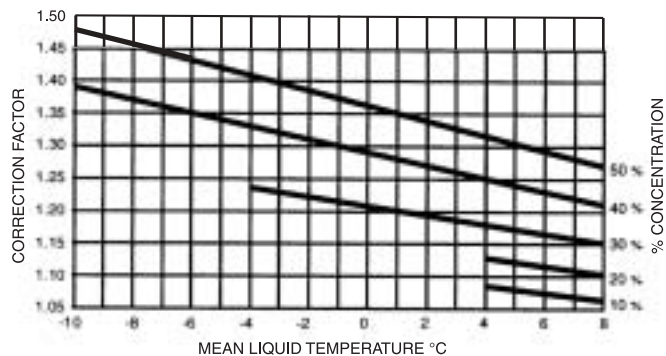

**FIGURE 7 - PRESSURE DROP CORRECTION FACTORS FOR ETHYLENE GLYCOL SOLUTIONS**

**FIGURE 8 - PRESSURE DROP CORRECTION FACTORS FOR PROPYLENE GLYCOL SOLUTIONS**

**TABLE 1 - CORRECTION FACTORS**

% By Weight	Ethylene Glycol (pgs 20 - 23)		Propylene Glycol (pgs 24 - 27)	
	Capacity Factor	Comp. Input Factor (kW)	Capacity Factor	Comp. Input Factor (kW)
10	1.009	1.003	1.011	1.004
20	1.004	1.002	1.006	1.003
30	1.000	1.000	1.000	1.000
40	0.995	0.998	0.988	0.996
50	0.988	0.996	0.975	0.992

# Part Load Ratings

## English

<b>YCWS0100SB</b>			
Load	Tons	kW	EER
100%	88.5	79.0	13.4
75%	66.4	55.5	14.4
50%	44.3	27.5	19.3
25%	22.1	21.2	12.5
<b>IPLV: 16.4 EER</b>			

<b>YCWS0200SB</b>			
Load	Tons	kW	EER
100%	175.6	142.3	14.8
75%	131.7	99.1	16.0
50%	87.8	48.1	22.0
25%	44.0	36.4	14.5
<b>IPLV: 18.5 EER</b>			

<b>YCWS0120SB</b>			
Load	Tons	kW	EER
100%	106.3	96.7	13.2
75%	79.7	67.1	14.3
50%	53.2	35.1	18.2
25%	26.6	27.6	11.5
<b>IPLV: 15.7 EER</b>			

<b>YCWS0220SB</b>			
Load	Tons	kW	EER
100%	191.0	157.5	14.6
75%	143.3	109.4	15.7
50%	95.5	56.0	20.5
25%	47.8	43.2	13.3
<b>IPLV: 17.6 EER</b>			

<b>YCWS0140SB</b>			
Load	Tons	kW	EER
100%	125.6	114.4	13.2
75%	94.2	78.5	14.4
50%	62.8	38.2	19.7
25%	31.4	28.5	13.2
<b>IPLV: 16.6 EER</b>			

<b>YCWS0240SB</b>			
Load	Tons	kW	EER
100%	208.8	173.0	14.5
75%	156.6	119.8	15.7
50%	104.4	58.2	21.5
25%	52.2	44.0	14.3
<b>IPLV: 18.1 EER</b>			

<b>YCWS0180SB</b>			
Load	Tons	kW	EER
100%	155.1	125.7	14.8
75%	116.3	87.7	15.9
50%	77.5	45.0	20.7
25%	38.8	34.2	13.6
<b>IPLV: 17.8 EER</b>			

Rated in accordance with ARI Standard 550/590

## SI

<b>YCWS0100SB</b>			
Load	kWo	kWi	COP
100%	312.0	79.1	3.95
75%	233.5	55.5	4.21
50%	155.8	27.5	5.67
25%	77.7	21.2	3.67
<b>IPLV: 4.8 COP</b>			

<b>YCWS0200SB</b>			
Load	kWo	kWi	COP
100%	617.9	142.6	4.33
75%	463.2	99.1	4.67
50%	308.8	48.1	6.42
25%	154.7	36.4	4.25
<b>IPLV: 5.4 COP</b>			

<b>YCWS0120SB</b>			
Load	kWo	kWi	COP
100%	374.7	96.8	3.87
75%	280.3	67.1	4.18
50%	187.1	35.1	5.33
25%	93.6	27.6	3.39
<b>IPLV: 4.6 COP</b>			

<b>YCWS0220SB</b>			
Load	kWo	kWi	COP
100%	672.0	157.9	4.26
75%	504.0	109.4	4.61
50%	335.9	56.0	6.00
25%	168.1	43.2	3.89
<b>IPLV: 5.1 COP</b>			

<b>YCWS0140SB</b>			
Load	kWo	kWi	COP
100%	443.2	114.5	3.87
75%	331.3	78.5	4.22
50%	220.9	38.2	5.78
25%	110.4	28.5	3.87
<b>IPLV: 4.9 COP</b>			

<b>YCWS0240SB</b>			
Load	kWo	kWi	COP
100%	734.9	173.3	4.24
75%	550.8	119.8	4.60
50%	367.2	58.2	6.31
25%	183.6	44.0	4.17
<b>IPLV: 5.3 COP</b>			

<b>YCWS0180SB</b>			
Load	kWo	kWi	COP
100%	545.6	126.0	4.33
75%	409.0	87.7	4.66
50%	272.6	45.0	6.06
25%	136.5	34.2	3.99
<b>IPLV: 5.2 COP</b>			

Rated in accordance with ARI Standard 550/590

# Physical Data

## English

MODEL YCWS	0100SB	0120SB	0140SB	0180SB	0200SB	0220SB	0240SB
<b>General Unit Data</b>							
Nominal Unit Capacity (Tons)	88.5	106.2	125.6	155.1	175.6	191.0	208.8
Number of Independent Refrigerant Circuits	2	2	2	2	2	2	2
Refrigerant Charge, R-407C, Ckt 1/Ckt. 2 (lbs.)	100/100	100/120	120/120	210/220	220/220	220/240	240/240
Oil Charge, Ckt. 1/Ckt. 2, (gal.)	2/2	2/3	3/3	3/3	3/3	3/3	3/3
Shipping Weight (lbs.)	7323	7632	7972	11722	11840	11897	12006
Operating Weight (lbs.)	8160	8469	8809	13256	13374	13393	13502
<b>Compressors, Semi-Hermetic Twin Screw</b>							
Quantity per Chiller	2	2	2	2	2	2	2
Nominal Size, Ckt. 1/ Ckt. 2	F/F	F/C	C/C	C/A	A/A	A/B	B/B
<b>Condenser - Code</b>							
Water Volume (gal.)	26	26	26	61	61	61	61
Maximum Water Side Pressure (psig)	150	150	150	150	150	150	150
Maximum Refrigerant Side Pressure (psig)	330	330	330	330	330	330	330
Dia. X Length, inches	16 x 108	16 x 108	16 x 108	18 x 156	18 x 156	18 x 156	18 x 156
Water Nozzle Connection Size, (inches)	5	5	5	6	6	6	6
<b>Evaporator, Direct Expansion - Code</b>							
Water Volume (gals.)	64	64	64	94	94	107	107
Maximum Water Side Pressure (psig)	150	150	150	150	150	150	150
Maximum Refrigerant Side Pressure (psig)	300	300	300	300	300	300	300
Dia. X Length, inches	19-1/2x 108	19-1/2x 108	19-1/2 x 108	21-1/4 x 156	21-1/4x 156	21-1/4x 156	21-1/4 x 156
Water Nozzle Connection Size, (inches)	8	8	8	8	8	8	8

## SI

MODEL YCWS	0100SB	0120SB	0140SB	0180SB	0200SB	0220SB	0240SB
<b>General Unit Data</b>							
Nominal Unit Capacity (kW)	312.0	374.7	443.2	545.6	617.9	672.0	734.9
Number of Independent Refrigerant Circuits	2	2	2	2	2	2	2
Refrigerant Charge, R407C, Ckt 1/Ckt. 2 (kgs.)	46/46	46/55	55/55	95/100	100/100	100/109	109/109
Oil Charge, Ckt. 1/Ckt. 2, (l)	7.6 / 7.6	7.6 / 11.4	11.4 / 11.4	11.4 / 11.4	11.4 / 11.4	11.4 / 11.4	11.4 / 11.4
Shipping Weight (kg.)	3322	3464	3616	5317	5370	5396	5446
Operating Weight (kg.)	3701	3841	3996	6013	6066	6075	6124
<b>Compressors, Semi-Hermetic Twin SBrew</b>							
Quantity per Chiller	2	2	2	2	2	2	2
Nominal Size, Ckt. 1/ Ckt. 2	F/F	F/C	C/C	C/A	A/A	A/B	B/B
<b>Condenser - Code</b>							
Water Volume (l)	98	98	98	230	230	230	230
Maximum Water Side Pressure (barg)	10.0	10.0	10.0	10.0	10.0	10.0	10.0
Maximum Refrigerant Side Pressure (barg)	22.8	22.8	22.8	22.8	22.8	22.8	22.8
Dia. X Length, mm	406 x 2743	406 x 2743	406 x 2743	457 x 3963	457 x 3963	457 x 3963	457 x 3963
Water Nozzle Connection Size, (inches)	5	5	5	6	6	6	6
<b>Evaporator, Direct Expansion - Code</b>							
Water Volume (l/s)	242	242	242	357	357	406	406
Maximum Water Side Pressure (barg)	10.0	10.0	10.0	10.0	10.0	10.0	10.0
Maximum Refrigerant Side Pressure (barg)	22.7	22.7	22.7	22.7	22.7	22.7	22.7
Dia. X Length, mm	495 x 2743	495 x 2743	495 x 2743	540 x 3963	540 x 3963	540 x 3963	540 x 3963
Water Nozzle Connection Size, (inches)	8	8	8	8	8	8	8



# Isolator Selection Data

### Weight Distribution by Model

Model	A	B	C	D	Oper. Weight (lbs)
YCWS0100SB	1997	1997	2082	2082	8160
YCWS0120SB	2104	2104	2131	2131	8469
YCWS0140SB	2210	2210	2195	2195	8809
YCWS0180SB	3314	3314	3314	3314	13256
YCWS0200SB	3336	3336	3351	3351	13374
YCWS0220SB	3333	3333	3363	3363	13393
YCWS0240SB	3355	3355	3395	3395	13502

Model	A	B	C	D	Oper. Weight (kg)
YCWS0100SB	906	906	945	945	3701
YCWS0120SB	954	954	967	967	3842
YCWS0140SB	1002	1002	995	995	3996
YCWS0180SB	1503	1503	1503	1503	6013
YCWS0200SB	1513	1513	1520	1520	6066
YCWS0220SB	1512	1512	1526	1526	6075
YCWS0240SB	1522	1522	1540	1540	6124

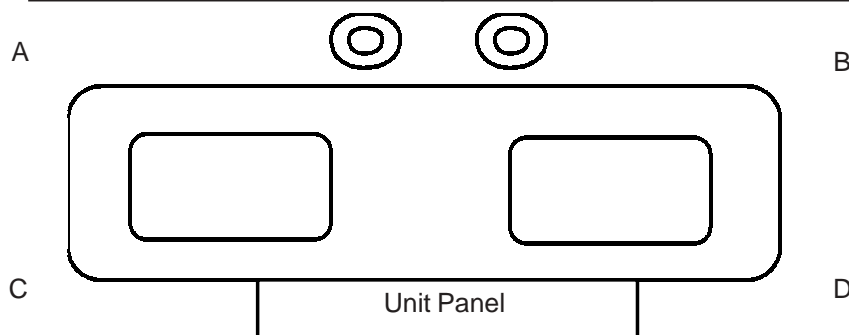

### Sesmic Isolator AWMR-X- Selections

Model	A	B	C	D
YCWS0100SB	2-530	2-530	2-530	2-530
YCWS0120SB	2-530	2-530	2-530	2-530
YCWS0140SB	2-530	2-530	2-530	2-530
YCWS0180SB	2-552	2-552	2-552	2-552
YCWS0200SB	2-552	2-552	2-552	2-552
YCWS0220SB	2-552	2-552	2-552	2-552
YCWS0240SB	2-552	2-552	2-552	2-552

### 1" Isolator Selections - VMC Type CP-4- X

Model	A	B	C	D
YCWS0100SB	26	26	26	26
YCWS0120SB	26	26	26	26
YCWS0140SB	26	26	26	26
YCWS0180SB	31	31	31	31
YCWS0200SB	31	31	31	31
YCWS0220SB	31	31	31	31
YCWS0240SB	31	31	31	31

### Neoprene -VMC Type RD-4 Selections

Model	A	B	C	D
YCWS0100SB	Green	Green	Green	Green
YCWS0120SB	Green	Green	Green	Green
YCWS0140SB	Green	Green	Green	Green
YCWS0180SB	Gray	Gray	Gray	Gray
YCWS0200SB	Gray	Gray	Gray	Gray
YCWS0220SB	Gray	Gray	Gray	Gray
YCWS0240SB	Gray	Gray	Gray	Gray

# Isolator Details

## 1" ISOLATOR DETAILS

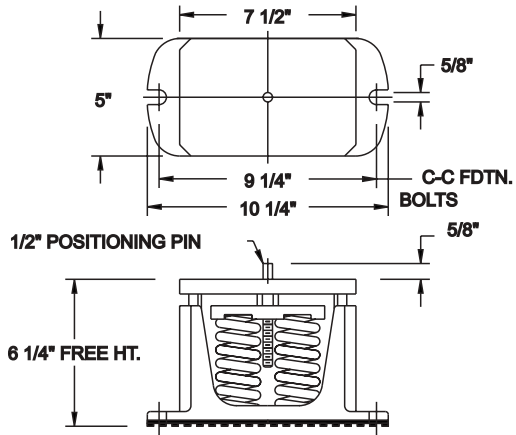

ENGLISH

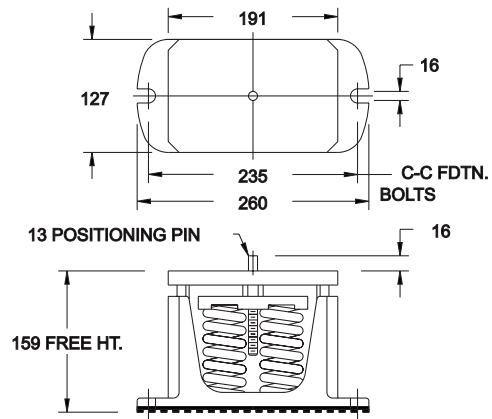

SI

TYPE SPRING & SIZE	MAX LOAD		DEFL.		COLOR
	lbs.	kg	in.	mm	
CP-4-26	2400	1088.6	1.17	29.7	Purple
CP-4-31	4400	1995.8	0.83	21.0	Gray

## ISOLATOR MOUNTING BRACKET

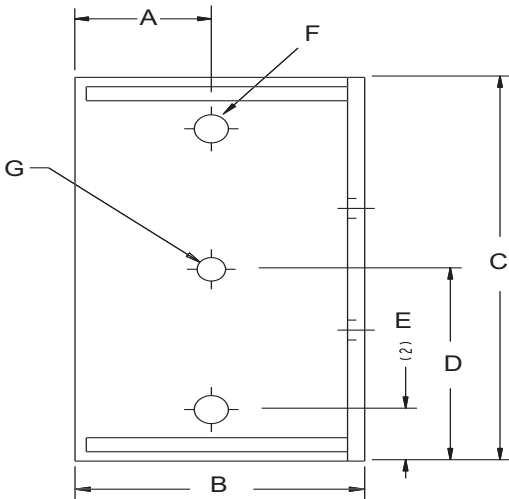

ISOLATOR BRACKET DIMENSIONS

Item	A	B	C	D
Eng (in)	3	6 3/8	10 1/4	5 1/8
SI (mm)	76	162	260	130

Item	E	F	G
Eng (in)	1 3/8	3/4	5/16
SI (mm)	35	19	8

## NEOPRENE ISOLATOR DETAILS

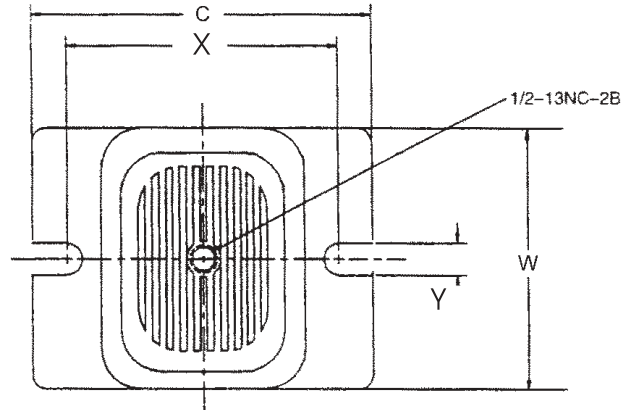

Mounting molded in Neoprene

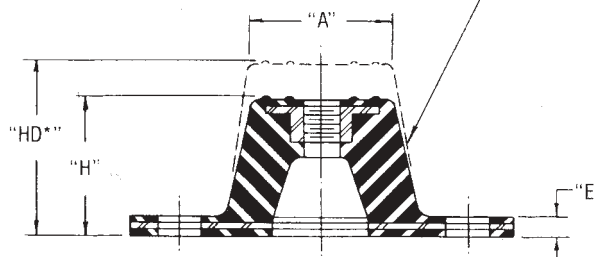

TYPE	A	C	E	H	HD	W	X	Y
R-4 or	3"	6.250"	0.4"	1.625"	2.75"	4.625"	5"	0.55"
RD-4	76mm	159mm	10mm	41mm	70mm	118mm	127mm	14mm

## SEISMIC ISOLATORS

TYPE & SIZE	MAX. LOAD		DEFL.	
	kg	lbs.	mm	in
AWMR-2-530	1043	2300	51	2
AWMR-2-552	1724	3800	51	2

## SEISMIC ISOLATOR DETAILS

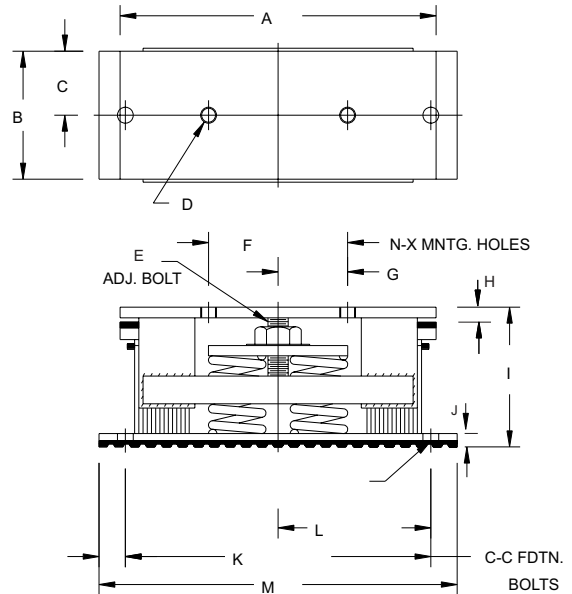

## AWMR DIMENSIONS

	A	B	C	D	E	F	G	H	I	J	K	L	M	N/X
AWMR-2 50-5XX	381mm	152mm	76mm	16 11NC	19mm	191mm	95mm	13mm	241mm	17mm	368mm	184mm	432mm	19mm 16mm

	A	B	C	D	E	F	G	H	I	J	K	L	M	N/X
AWMR-2 50-5XX	15"	6"	3"	16 11NC	1"	7.5"	3-3/4"	1/2"	9"	5/8"	14.5"	7-1/4"	17.25"	3/8" 5/8"

# Sound Data

Sound Pressure Levels (SPL), dB re 20 microPa in accordance with ARI Standard 575-94

MODEL	Octave Band Hz								Weighted dBA
	63	125	250	500	1000	2000	4000	8000	
YCWS0100SB	76	72	71.5	76	75	73	64	62	79
YCWS0120SB	76	72	72	77	76	73	64	62	80
YCWS0140SB	76	72	72.5	78	77	74	65	62	81
YCWS0180SB	76	73	73	79	78.5	75	65	62	82
YCWS0200SB	76	73	73.5	80	79.5	76	66	62	83
YCWS0220SB	76	74	74	81	80.5	77	66.5	62	84
YCWS0240SB	76	74	75	82	81.5	78	67	62	85

Note: All 'A' weighted sound pressure data  $\pm$  3 dBA

# Dimensions (English)

## Mounting Dimensions

Model	AA	BB	CC
YCWS0100SB	115-5/8	34	23-3/4
YCWS0120SB	115-5/8	34	23-3/4
YCWS0140SB	115-5/8	34	23-3/4
YCWS0180SB	162-7/8	36	25-3/4
YCWS0200SB	162-7/8	36	25-3/4
YCWS0220SB	162-7/8	36	25-3/4
YCWS0240SB	162-7/8	36	25-3/4

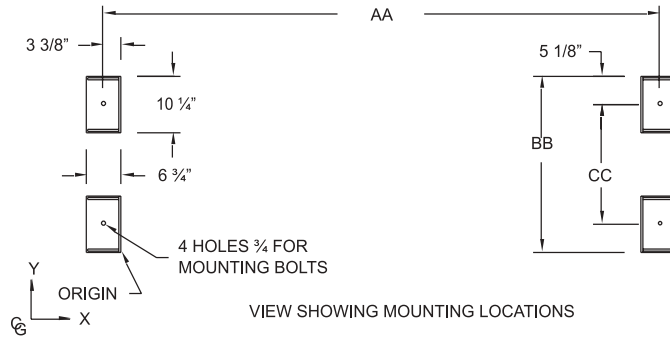

## Center of gravity (inches)

Model	X	Y	Z
YCWS0100SB	57	21	34
YCWS0120SB	58	22	34
YCWS0140SB	57	22	34
YCWS0180SB	80	24	36
YCWS0200SB	80	24	36
YCWS0220SB	80	24	37
YCWS0240SB	80	24	37

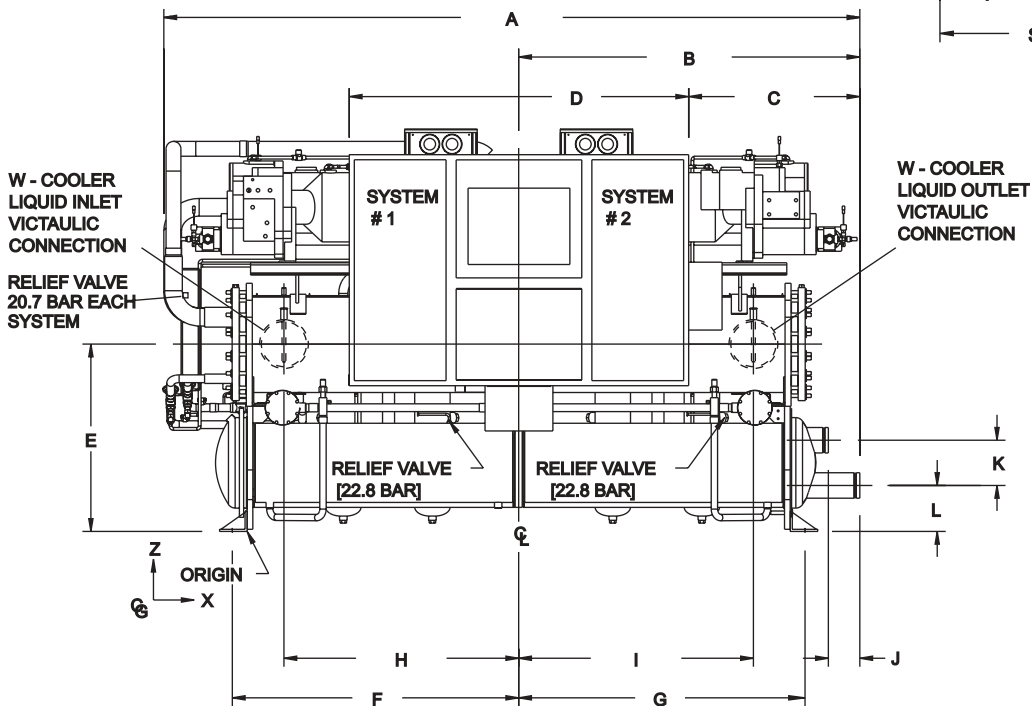
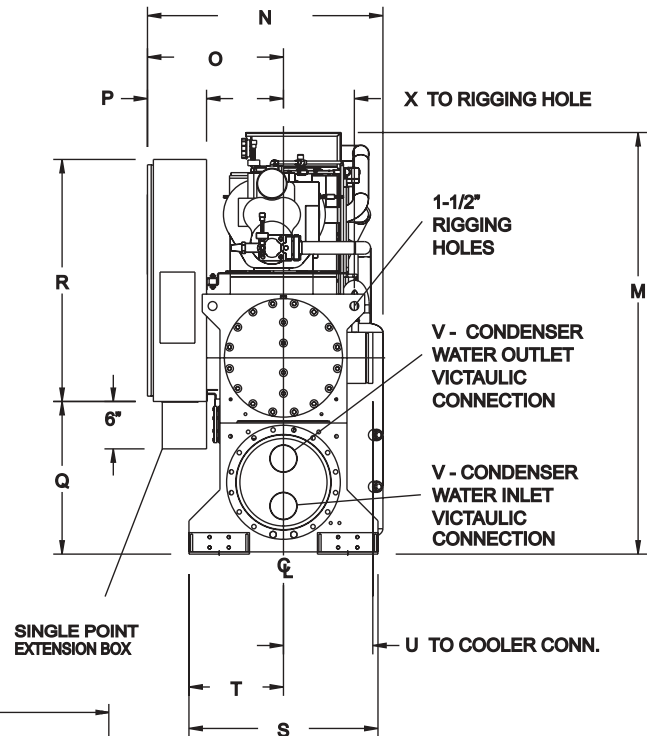

**DIMENSIONS**

REF	YCWS0100	YCWS0120	YCWS0140	YCWS0180	YCWS0200	YCWS0220	YCWS0240
A	138-7/8"	138-7/8"	138-7/8"	185-9/16"	185-9/16"	185-9/16"	185-9/16"
B	67-1/2"	67-1/2"	67-1/2"	91-3/16"	91-3/16"	91-3/16"	91-3/16"
C	37-1/2"	37-1/2"	37-1/2"	61-1/4"	61-1/4"	61-1/4"	61-1/4"
D	60"	60"	60"	60"	60"	60"	60"
E	36-5/8"	36-5/8"	36-5/8"	39-31/32"	39-31/32"	39-31/32"	39-31/32"
F	57-7/16"	57-7/16"	57-7/16"	81-7/16"	81-7/16"	81-7/16"	81-7/16"
G	57-7/16"	57-7/16"	57-7/16"	81-7/16"	81-7/16"	81-7/16"	81-7/16"
H	46-1/32"	46-1/32"	46-1/32"	67-13/16"	67-13/16"	67-13/16"	67-13/16"
I	46-1/32"	46-1/32"	46-1/32"	67-13/16"	67-13/16"	67-13/16"	67-13/16"
J	6-1/8"	6-1/8"	6-1/8"	5-1/8"	5-1/8"	5-1/8"	5-1/8"
K	8-1/4"	8-1/4"	8-1/4"	9"	9"	9"	9"
L	8-1/4"	8-1/4"	8-1/4"	9-7/8"	9-7/8"	9-7/8"	9-7/8"
M	72-17/32"	72-17/32"	72-17/32"	79-9/32"	79-9/32"	79-9/32"	79-9/32"
N	41-5/16"	41-5/16"	41-5/16"	41-27/32"	41-27/32"	41-27/32"	41-27/32"
O	23-11/16"	23-11/16"	23-11/16"	23-27/32"	23-27/32"	23-27/32"	23-27/32"
P	10"	10"	10"	10"	10"	10"	10"
Q	29-1/4"	29-1/4"	29-1/4"	32-15/16"	32-15/16"	32-15/16"	32-15/16"
R	40-7/8"	40-7/8"	40-7/8"	40-7/8"	40-7/8"	40-7/8"	40-7/8"
S	34"	34"	34"	36"	36"	36"	36"
T	17"	17"	17"	18"	18"	18"	18"
U	16-1/8"	16-1/8"	16-1/8"	16-5/8"	16-5/8"	16-5/8"	16-5/8"
V	5-1/2"	5-1/2"	5-1/2"	6-39/64"	6-39/64"	6-39/64"	6-39/64"
W	8-5/8"	8-5/8"	8-5/8"	8-5/8"	8-5/8"	8-5/8"	8-5/8"
X	13-1/4"	13-1/4"	13-1/4"	13-1/4"	13-1/4"	13-1/4"	13-1/4"

**REVISED DIMENSIONS FOR 200/230V CHILLERS**

REF	YCWS0100	YCWS0120	YCWS0140	YCWS0180	YCWS0200	YCWS0220	YCWS0240
C	32-1/4"	32-1/4"	32-1/4"	56"	56"	56"	56"
D	70-1/2"	70-1/2"	70-1/2"	70-1/2"	70-1/2"	70-1/2"	70-1/2"
Q	20-7/8"	20-7/8"	20-7/8"	25-15/16"	25-15/16"	25-15/16"	25-15/16"
R	48"	48"	48"	48"	48"	48"	48"

**NOTES:**

1. CLEARANCES - Recommended YORK clearances to service the unit are as follows:  
 Rear to Wall: 1' 8"  
 Front to Wall: 2' 8"  
 Top: 1' 8"  
 Tube cleaning and removal: 8' (either end)
2. Shipping skids (not shown) will increase the height of the unit by 6", but **MUST** be removed upon installation.
3. Spring and neoprene isolators will increase the overall height of the unit by approximately 3".
4. Seismic Isolators will increase the overall height of the unit by approximately 9-1/2".
5. To install 1" spring isolators, the feet/brackets in the unit should be flipped over 180 degrees, so that the isolators fit inside the "house".

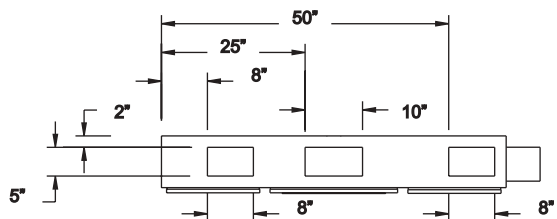

**VIEW SHOWING CUSTOMER POWER ENTRY LOCATIONS ON UNDERSIDE OF PANEL**

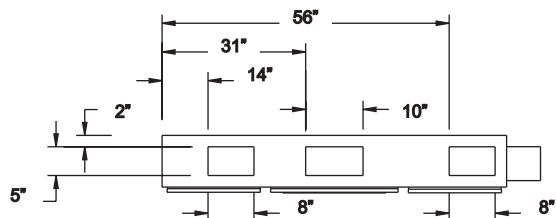

**VIEW SHOWING DIMENSIONS FOR 200/230V PANEL**

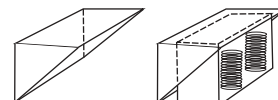

Mounting Dimensions (mm)			
Model	AA	BB	CC
YCWS0100SB	2937	864	603
YCWS0120SB	2937	864	603
YCWS0140SB	2937	864	603
YCWS0180SB	4137	914	654
YCWS0200SB	4137	914	654
YCWS0220SB	4137	914	654
YCWS0240SB	4137	914	654

Center of gravity (mm)			
Model	X	Y	Z
YCWS0100SB	1442	545	862
YCWS0120SB	1464	550	866
YCWS0140SB	1443	554	870
YCWS0180SB	2031	613	920
YCWS0200SB	2026	612	925
YCWS0220SB	2034	611	928
YCWS0240SB	2029	610	932

All dimensions are in mm unless otherwise noted.

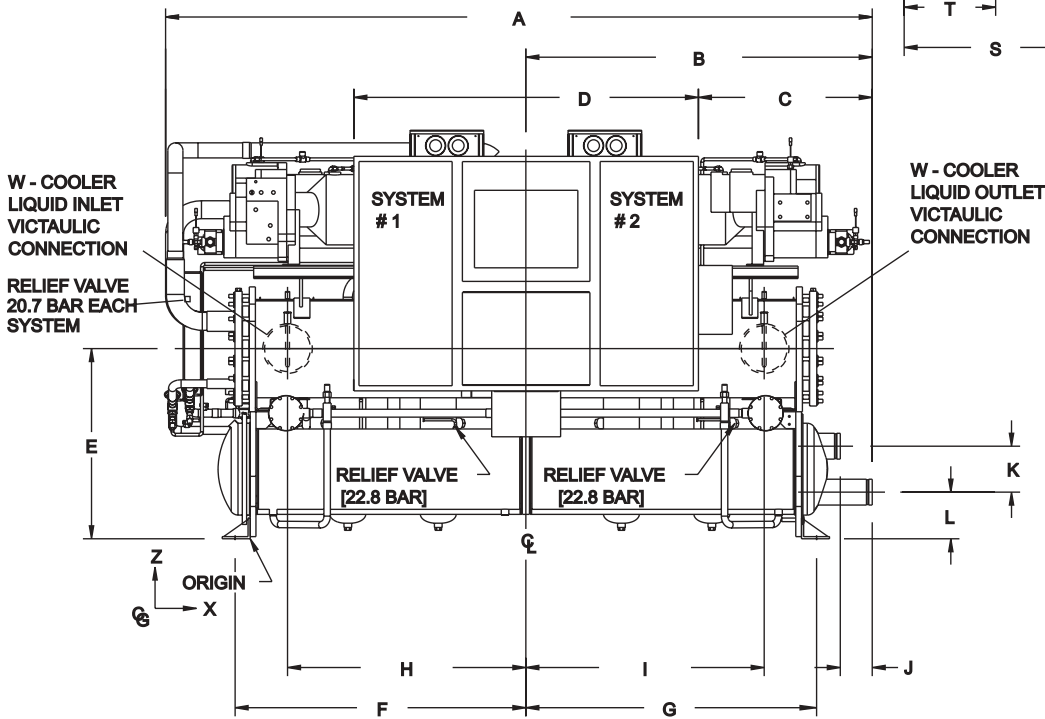
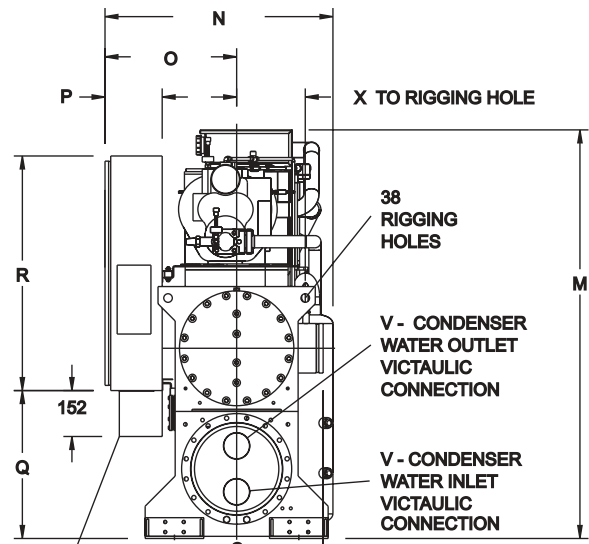
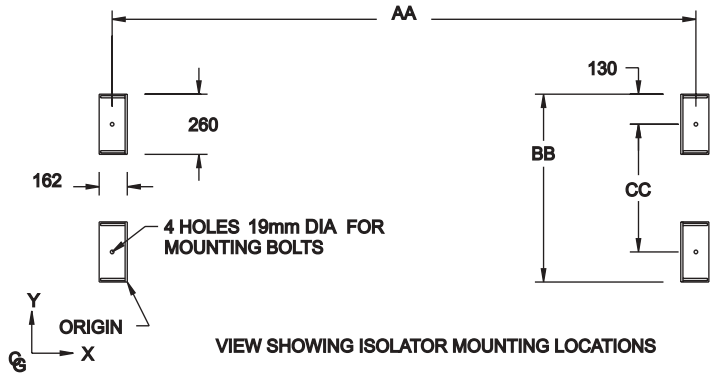

REF NO	YCWS0100	YCWS0120	YCWS0140	YCWS0180	YCWS0200	YCWS0220	YCWS0240
A	3527	3527	3527	4714	4714	4714	4714
B	1715	1715	1715	2316	2316	2316	2316
C	953	953	953	1556	1556	1556	1556
D	1524	1524	1524	1524	1524	1524	1524
E	930	930	930	1015	1015	1015	1015
F	1459	1459	1459	2069	2069	2069	2069
G	1459	1459	1459	2069	2069	2069	2069
H	1169	1169	1169	1722	1722	1722	1722
I	1169	1169	1169	1722	1722	1722	1722
J	156	156	156	130	130	130	130
K	210	210	210	229	229	229	229
L	210	210	210	251	251	251	251
M	1842	1842	1842	2014	2014	2014	2014
N	1049	1049	1049	1063	1063	1063	1063
O	602	602	602	606	606	606	606
P	254	254	254	254	254	254	254
Q	743	743	743	837	837	837	837
R	1038	1038	1038	1038	1038	1038	1038
S	864	864	864	914	914	914	914
T	432	432	432	457	457	457	457
U	410	410	410	422	422	422	422
V	141	141	141	168	168	168	168
W	219	219	219	219	219	219	219
X	337	337	337	337	337	337	337

REVISED DIMENSIONS FOR 200/230V CHILLERS

REF	YCWS0100	YCWS0120	YCWS0140	YCWS0180	YCWS0200	YCWS0220	YCWS0240
C	819	819	819	1422	1422	1422	1422
D	1791	1791	1791	1791	1791	1791	1791
Q	530	530	530	659	659	659	659
R	1219	1219	1219	1219	1219	1219	1219

NOTES:

- CLEARANCES - Recommended YORK clearances to service the unit are as follows:  
 Rear to Wall: 508mm  
 Front to Wall: 813mm  
 Top: 508mm  
 Tube cleaning and removal: 2438mm (either end)
- Shipping skids (not shown) will increase the height of the unit by 152mm, but **MUST** be removed upon installation.
- Spring and neoprene isolators will increase the overall height of the unit by approximately 76mm.
- Sismic Isolators will increase the overall height of the unit by approximately 241 mm.
- To install 25mm spring isolators, the feet/brackets in the unit should be flipped over 180 degrees, so the isolators fit inside the "house".

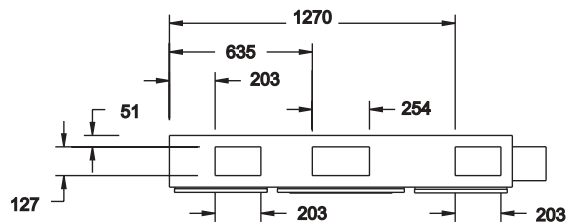

VIEW SHOWING CUSTOMER POWER ENTRY LOCATIONS ON UNDERSIDE OF PANEL

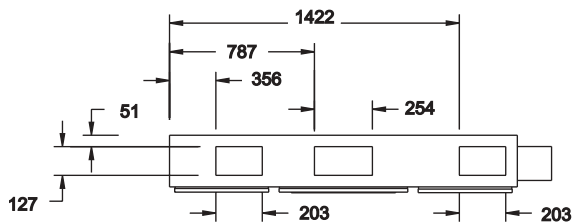

VIEW SHOWING DIMENSIONS FOR 200/230V PANEL

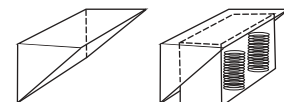

# Electrical Data

## MULTIPOINT POWER SUPPLY (SEE FIG 9 , PAGE 34)

(Each of the two field provided power supply circuits individually protected with branch circuit protection. Field connections to factory provided Terminal Block(std), Non-Fused Disconnects(opt) or individual system Circuit Breakers(opt) in each of the two motor control centers.)

SYSTEM #1							
CHILLER MODEL	VOLT CODE HZ	MIN <sup>(1)</sup> CIR. MCA	MIN NF DISC SW	MIN DUAL FUSE	MAX DUAL FUSE MAX CB	RLA	Y-D LRA
YCWS0100SB	-17	189	200	250	300	151	404
YCWS0120SB		187	200	225	300	149	404
YCWS0140SB		253	250	350	450	202	591
YCWS0180SB		242	250	300	400	193	591
YCWS0200SB		308	400	400	500	246	708
YCWS0220SB		308	400	400	500	246	708
YCWS0240SB		369	400	450	600	295	708
YCWS0100SB	-28	164	200	200	250	131	354
YCWS0120SB		163	150	200	250	130	354
YCWS0140SB		219	250	300	350	175	481
YCWS0180SB		210	200	300	350	168	481
YCWS0200SB		268	250	350	450	214	642
YCWS0220SB		268	250	350	450	214	642
YCWS0240SB		320	400	400	500	256	642
YCWS0100SB	-40	99	100	125	175	79	219
YCWS0120SB		99	100	125	175	79	219
YCWS0140SB		133	150	175	225	106	285
YCWS0180SB		127	150	175	225	101	285
YCWS0200SB		163	150	200	250	130	343
YCWS0220SB		163	150	200	250	130	343
YCWS0240SB		194	200	250	300	155	343
YCWS0100SB	-46	82	100	100	125	65	174
YCWS0120SB		82	100	100	125	65	174
YCWS0140SB		110	150	150	175	88	228
YCWS0180SB		105	100	150	175	84	228
YCWS0200SB		135	150	175	225	108	280
YCWS0220SB		135	150	175	225	108	280
YCWS0240SB		160	150	200	250	128	280
YCWS0100SB	-58	67	100	80	110	53	138
YCWS0120SB		65	60	80	110	52	138
YCWS0140SB		88	100	110	150	70	182
YCWS0180SB		84	100	110	150	67	182
YCWS0200SB		107	100	150	175	85	224
YCWS0220SB		107	100	150	175	85	224
YCWS0240SB		129	150	175	225	103	224



## SYSTEM #2

CHILLER MODEL	VOLT CODE HZ	MIN <sup>(1)</sup> CIR. MCA	MIN NF DISC SW	MIN DUAL FUSE	MAX DUAL FUSE MAX CB	RLA	Y-D LRA
YCWS0100SB	-17	189	200	250	300	151	404
YCWS0120SB		253	250	350	450	202	591
YCWS0140SB		253	250	350	450	202	591
YCWS0180SB		308	400	400	500	246	708
YCWS0200SB		308	400	400	500	246	708
YCWS0220SB		369	400	450	600	295	708
YCWS0240SB		369	400	450	600	295	708
YCWS0100SB	-28	164	200	200	250	131	354
YCWS0120SB		222	250	300	350	177	481
YCWS0140SB		219	250	300	350	175	481
YCWS0180SB		268	250	350	450	214	642
YCWS0200SB		268	250	350	450	214	642
YCWS0220SB		320	400	400	500	256	642
YCWS0240SB		320	400	400	500	256	642
YCWS0100SB	-40	99	100	125	175	79	219
YCWS0120SB		135	150	175	225	108	285
YCWS0140SB		133	150	175	225	106	285
YCWS0180SB		163	150	200	250	130	343
YCWS0200SB		163	150	200	250	130	343
YCWS0220SB		194	200	250	300	155	343
YCWS0240SB		194	200	250	300	155	343
YCWS0100SB	-46	82	100	100	125	65	174
YCWS0120SB		112	150	150	200	89	228
YCWS0140SB		110	150	150	175	88	228
YCWS0180SB		135	150	175	225	108	280
YCWS0200SB		135	150	175	225	108	280
YCWS0220SB		160	150	200	250	128	280
YCWS0240SB		160	150	200	250	128	280
YCWS0100SB	-58	67	100	80	110	53	138
YCWS0120SB		89	100	110	150	71	182
YCWS0140SB		88	100	110	150	70	182
YCWS0180SB		107	100	150	175	85	224
YCWS0200SB		107	100	150	175	85	224
YCWS0220SB		129	150	175	225	103	224
YCWS0240SB		129	150	175	225	103	224

# Electrical Data - Cont.

## SINGLE POINT POWER SUPPLY (SEE FIG 10 & 11 , PAGE 34 & 35)

(One field provided power supply circuit to the control panel. Field connections to factory provided Terminal Blocks(opt) or Non-Fused Disconnect(opt). Individual system Circuit Breakers, Non-Fused Disconnects or Class 'J' Fuse/Fuse Blocks in each motor control center.)

CHILLER MODELS	VOLT CODE HZ	MIN <sup>(1)</sup> CIR MCA	MIN N/F DISC SW	MIN DUAL FUSE	MAX DUAL FUSE MAX CB	SYSTEM #1		SYSTEM #2	
						RLA	Y-D LRA	RLA	Y-D LRA
YCWS0100SB	-17	340	400	400	450	151	404	151	404
YCWS0120SB		402	600	500	600	149	404	202	591
YCWS0140SB		455	600	600	600	202	591	202	591
YCWS0180SB		501	600	600	700	193	591	246	708
YCWS0200SB		554	600	700	700	246	708	246	708
YCWS0220SB		615	800	700	800	246	708	295	708
YCWS0240SB		664	800	800	800	295	708	295	708
YCWS0100SB	-28	295	400	350	400	131	354	131	354
YCWS0120SB		351	400	400	500	130	354	177	481
YCWS0140SB		394	600	450	500	175	481	175	481
YCWS0180SB		436	600	500	600	168	481	214	642
YCWS0200SB		482	600	600	600	214	642	214	642
YCWS0220SB		534	600	600	700	214	642	256	642
YCWS0240SB		576	600	700	800	256	642	256	642
YCWS0100SB	-40	178	200	200	250	79	219	79	219
YCWS0120SB		214	250	250	300	79	219	108	285
YCWS0140SB		239	250	300	300	106	285	106	285
YCWS0180SB		264	400	300	350	101	285	130	343
YCWS0200SB		293	400	350	400	130	343	130	343
YCWS0220SB		324	400	400	450	130	343	155	343
YCWS0240SB		349	400	400	500	155	343	155	343
YCWS0100SB	-46	146	150	175	200	65	174	65	174
YCWS0120SB		176	200	200	250	65	174	89	228
YCWS0140SB		198	250	225	250	88	228	88	228
YCWS0180SB		219	250	250	300	84	228	108	280
YCWS0200SB		243	250	300	350	108	280	108	280
YCWS0220SB		268	400	350	350	108	280	128	280
YCWS0240SB		288	400	350	400	128	280	128	280
YCWS0100SB	-58	119	150	150	150	53	138	53	138
YCWS0120SB		141	150	175	200	52	138	71	182
YCWS0140SB		158	200	200	225	70	182	70	182
YCWS0180SB		173	200	200	250	67	182	85	224
YCWS0200SB		191	200	225	250	85	224	85	224
YCWS0220SB		214	250	250	300	85	224	103	224
YCWS0240SB		232	250	300	300	103	224	103	224

# Incoming Wire Range Selections

## SINGLE POINT POWER SUPPLY

MODEL NUMBER	SYSTEM # 1 & #2				
	VOLT CODE	TERM BLK	TERM BLK CUSTOMER GROUND	N-F DIS SW	N-F DIS SW CUSTOMER GROUND
YCWS0100SB	-17	#2/0 - 500 KCM	# 4 - 3/0 AWG	250 - 500 KCM	# 4 - 3/0 AWG
YCWS0120SB		(2) #2 - 300 KCM	(2) # 4 - 3/0 AWG	(2) 250 - 500 KCM	(2) # 4 - 3/0 AWG
YCWS0140SB		(2) #2 - 300 KCM	(2) # 4 - 3/0 AWG	(2) 250 - 500 KCM	(2) # 4 - 3/0 AWG
YCWS0180SB		(2) #2/0 - 500 KCM	(2) # 4 - 3/0 AWG	(2) 250 - 500 KCM	(2) # 4 - 3/0 AWG
YCWS0200SB		(2) #2/0 - 500 KCM	(2) # 4 - 3/0 AWG	(2) 250 - 500 KCM	(2) # 2 - 4/0 AWG
YCWS0220SB		(2) #2/0 - 500 KCM	(2) # 4 - 3/0 AWG	(2) 250 - 500 KCM	(2) # 2 - 4/0 AWG
YCWS0240SB		(2) #2/0 - 500 KCM	(2) # 4 - 3/0 AWG	(2) 250 - 500 KCM	(2) # 2 - 4/0 AWG
YCWS0100SB	-28	#2/0 - 500 KCM	# 4 - 3/0 AWG	250 - 500 KCM	# 4 - 3/0 AWG
YCWS0120SB		(2)# 2 - 4/0 AWG	(2) # 6 - 1/0 AWG	(2) #3/0 - 250 KCM	(2)#6 - 1/0 AWG
YCWS0140SB		(2) #2 - 300 KCM	(2) # 4 - 3/0 AWG	(2) 250 - 500 KCM	(2) # 4 - 3/0 AWG
YCWS0180SB		(2) #2 - 300 KCM	(2) # 4 - 3/0 AWG	(2) 250 - 500 KCM	(2) # 4 - 3/0 AWG
YCWS0200SB		(2) #2/0 - 500 KCM	(2) # 4 - 3/0 AWG	(2) 250 - 500 KCM	(2) # 4 - 3/0 AWG
YCWS0220SB		(2) #2/0 - 500 KCM	(2) # 4 - 3/0 AWG	(2) 250 - 500 KCM	(2) # 4 - 3/0 AWG
YCWS0240SB		(2) #2/0 - 500 KCM	(2) # 4 - 3/0 AWG	(2) 250 - 500 KCM	(2) # 2 - 4/0 AWG
YCWS0100SB	-40	#2 - 4/0 AWG	# 8 - 2 AWG	#4 - 300 KCM	# 6 - 1/0 AWG
YCWS0120SB		#2 - 300 KCM	# 6 - 1/0 AWG	#6 - 350 KCM	# 6 - 1/0 AWG
YCWS0140SB		#2/0 - 500 KCM	# 4 - 3/0 AWG	250 - 500 KCM	# 4 - 3/0 AWG
YCWS0180SB		#2/0 - 500 KCM	# 4 - 3/0 AWG	250 - 500 KCM	# 4 - 3/0 AWG
YCWS0200SB		#2/0 - 500 KCM	# 4 - 3/0 AWG	250 - 500 KCM	# 4 - 3/0 AWG
YCWS0220SB		#2/0 - 500 KCM	# 4 - 3/0 AWG	250 - 500 KCM	# 4 - 3/0 AWG
YCWS0240SB		#2/0 - 500 KCM	# 4 - 3/0 AWG	250 - 500 KCM	# 4 - 3/0 AWG
YCWS0100SB	-46	#2 - 4/0 AWG	# 8 - 2 AWG	#4 - 300 KCM	# 6 - 1/0 AWG
YCWS0120SB		#2 - 4/0 AWG	# 8 - 2 AWG	#4 - 300 KCM	# 6 - 1/0 AWG
YCWS0140SB		#2 - 300 KCM	# 6 - 1/0 AWG	#4 - 300 KCM	# 6 - 1/0 AWG
YCWS0180SB		#2 - 300 KCM	# 6 - 1/0 AWG	#6 - 350 KCM	# 6 - 1/0 AWG
YCWS0200SB		#2/0 - 500 KCM	# 4 - 3/0 AWG	250 - 500 KCM	# 4 - 3/0 AWG
YCWS0220SB		#2/0 - 500 KCM	# 4 - 3/0 AWG	250 - 500 KCM	# 4 - 3/0 AWG
YCWS0240SB		#2/0 - 500 KCM	# 4 - 3/0 AWG	250 - 500 KCM	# 4 - 3/0 AWG
YCWS0100SB	-58	#6 - 1/0 AWG	# 8 - 2 AWG	#2 - 4/0 AWG	# 8 - 2 AWG
YCWS0120SB		#2 - 4/0 AWG	# 8 - 2 AWG	#6 - 350 KCM	#6 - 1/0 AWG
YCWS0140SB		#2 - 4/0 AWG	# 8 - 2 AWG	#6 - 350 KCM	#6 - 1/0 AWG
YCWS0180SB		#2 - 4/0 AWG	# 8 - 2 AWG	#6 - 350 KCM	#6 - 1/0 AWG
YCWS0200SB		#2 - 300 KCM	# 6 - 1/0 AWG	#6 - 350 KCM	#6 - 1/0 AWG
YCWS0220SB		#2 - 300 KCM	# 6 - 1/0 AWG	#6 - 350 KCM	#6 - 1/0 AWG
YCWS0240SB		#2 - 300 KCM	# 6 - 1/0 AWG	250 - 500 KCM	#4 - 3/0 AWG

# Incoming Wire Range Selections (Cont.)

## MULTIPOINT WIRING SYSTEM #1

CHILLER MODEL	VOLT CODE	TERM BLK	TERMINAL BLK CUSTOMER GROUND	N-F DIS SW	N-F DIS SW CUSTOMER GROUND	CKT.BRKR	CKT.BRKR CUSTOMER GROUND
YCWS0100SE	-17	#2 - 300 KCM	# 6 - 1/0 AWG	#4 - 300 KCM	# 6 - 1/0 AWG	#6 - 350 KCM	# 6 - 1/0 AWG
YCWS0120SE		#1/0 - 300 KCM	# 6 - 1/0 AWG	#4 - 300 KCM	# 6 - 1/0 AWG	#6 - 350 KCM	# 6 - 1/0 AWG
YCWS0140SE		#2/0 - 500 KCM	# 4 - 3/0 AWG	#6 - 350 KCM	# 6 - 1/0 AWG	250 - 500 KCM	# 4 - 3/0 AWG
YCWS0180SE		#2/0 - 500 KCM	# 4 - 3/0 AWG	#6 - 350 KCM	# 6 - 1/0 AWG	250 - 500 KCM	# 4 - 3/0 AWG
YCWS0200SE		#2/0 - 500 KCM	# 4 - 3/0 AWG	250 - 500 KCM	# 2 - 4/0 AWG	250 - 500 KCM	# 4 - 3/0 AWG
YCWS0220SE		#2/0 - 500 KCM	# 4 - 3/0 AWG	250 - 500 KCM	# 2 - 4/0 AWG	250 - 500 KCM	# 4 - 3/0 AWG
YCWS0240SE		(2) #2-4/0 AWG	(2) # 6 - 1/0 AWG	(2) #3/0-250 KCM	# 2 - 4/0 AWG	(2)250 - 500 KCM	(2) # 2 - 4/0 AWG
YCWS0100SE	-28	#2 - 4/0 AWG	# 8 - 2 AWG	#4 - 300 KCM	# 6 - 1/0 AWG	#4 - 300 KCM	# 6 - 1/0 AWG
YCWS0120SE		#2 - 4/0 AWG	# 8 - 2 AWG	#4 - 300 KCM	# 6 - 1/0 AWG	#4 - 300 KCM	# 6 - 1/0 AWG
YCWS0140SE		#2 - 300 KCM	# 6 - 1/0 AWG	#4 - 300 KCM	# 6 - 1/0 AWG	#4 - 300 KCM	# 4 - 3/0 AWG
YCWS0180SE		#2 - 300 KCM	# 6 - 1/0 AWG	#4 - 300 KCM	# 6 - 1/0 AWG	250 - 500 KCM	# 4 - 3/0 AWG
YCWS0200SE		#2/0 - 500 KCM	# 4 - 3/0 AWG	250 - 500 KCM	# 4 - 3/0 AWG	250 - 500 KCM	# 4 - 3/0 AWG
YCWS0220SE		#2/0 - 500 KCM	# 4 - 3/0 AWG	250 - 500 KCM	# 4 - 3/0 AWG	250 - 500 KCM	# 4 - 3/0 AWG
YCWS0240SE		#2/0 - 500 KCM	# 4 - 3/0 AWG	250 - 500 KCM	# 2 - 4/0 AWG	(2)250 - 500 KCM	(2)# 2 - 4/0 AWG
YCWS0100SE	-40	#6 - 1/0 AWG	# 8 - 2 AWG	#14 - 1/0 AWG	# 8 - 2 AWG	#4 - 300 KCM	# 8 - 2 AWG
YCWS0120SE		#6 - 1/0 AWG	# 8 - 2 AWG	#14 - 1/0 AWG	# 8 - 2 AWG	#4 - 300 KCM	# 8 - 2 AWG
YCWS0140SE		#2 - 4/0 AWG	# 8 - 2 AWG	#4 - 300 KCM	# 8 - 2 AWG	#4 - 300 KCM	# 6 - 1/0 AWG
YCWS0180SE		#2 - 4/0 AWG	# 8 - 2 AWG	#4 - 300 KCM	# 8 - 2 AWG	#4 - 300 KCM	# 6 - 1/0 AWG
YCWS0200SE		#2 - 4/0 AWG	# 8 - 2 AWG	#4 - 300 KCM	# 6 - 1/0 AWG	#4 - 300 KCM	# 6 - 1/0 AWG
YCWS0220SE		#2 - 4/0 AWG	# 8 - 2 AWG	#4 - 300 KCM	# 6 - 1/0 AWG	#4 - 300 KCM	# 6 - 1/0 AWG
YCWS0240SE		#2 - 300 KCM	# 6 - 1/0 AWG	#4 - 300 KCM	# 6 - 1/0 AWG	#6 - 350 KCM	# 6 - 1/0 AWG
YCWS0100SE	-46	#6 - 1/0 AWG	# 8 - 2 AWG	#14 - 1/0 AWG	# 8 - 2 AWG	#2 - 4/0 AWG	# 8 - 2 AWG
YCWS0120SE		#6 - 1/0 AWG	# 8 - 2 AWG	#14 - 1/0 AWG	# 8 - 2 AWG	#2 - 4/0 AWG	# 8 - 2 AWG
YCWS0140SE		#6 - 1/0 AWG	# 8 - 2 AWG	#4 - 300 KCM	# 8 - 2 AWG	#4 - 300 KCM	# 8 - 2 AWG
YCWS0180SE		# 6 - 1/0 AWG	# 8 - 2 AWG	#4 - 300 KCM	# 8 - 2 AWG	#4 - 300 KCM	# 8 - 2 AWG
YCWS0200SE		#2 - 4/0 AWG	# 8 - 2 AWG	#4 - 300 KCM	# 8 - 2 AWG	#4 - 300 KCM	# 6 - 1/0 AWG
YCWS0220SE		#2 - 4/0 AWG	# 8 - 2 AWG	#4 - 300 KCM	# 8 - 2 AWG	#4 - 300 KCM	# 6 - 1/0 AWG
YCWS0240SE		#2 - 4/0 AWG	# 8 - 2 AWG	#4 - 300 KCM	# 6 - 1/0 AWG	#4 - 300 KCM	# 6 - 1/0 AWG
YCWS0100SE	-58	#18 - 2 AWG	# 8 - 2 AWG	#14 - 1/0 AWG	# 8 - 2 AWG	#14 - 1/0 AWG	# 8 - 2 AWG
YCWS0120SE		#18 - 2 AWG	# 8 - 2 AWG	#14 - 1/0 AWG	# 8 - 2 AWG	#14 - 1/0 AWG	# 8 - 2 AWG
YCWS0140SE		#6 - 1/0 AWG	# 8 - 2 AWG	#14 - 1/0 AWG	# 8 - 2 AWG	#2 - 4/0 AWG	# 8 - 2 AWG
YCWS0180SE		#6 - 1/0 AWG	# 8 - 2 AWG	#14 - 1/0 AWG	# 8 - 2 AWG	#2 - 4/0 AWG	# 8 - 2 AWG
YCWS0200SE		#6 - 1/0 AWG	# 8 - 2 AWG	#4 - 300 KCM	# 8 - 2 AWG	#4 - 300 KCM	# 8 - 2 AWG
YCWS0220SE		#6 - 1/0 AWG	# 8 - 2 AWG	#4 - 300 KCM	# 8 - 2 AWG	#4 - 300 KCM	# 8 - 2 AWG
YCWS0240SE		#2 - 4/0 AWG	# 8 - 2 AWG	#4 - 300 KCM	# 8 - 2 AWG	#6 - 350 KCM	# 6 - 1/0 AWG

**NOTES:** (for Electrical Data on pages 26-28)

1. Minimum Circuit Ampacity (MCA) is based on 125% of the rated load amps for the largest motor plus 100% of the rated load amps for all other loads included in the circuit, per N.E.C. Article 430-33. If the optional Factory Mounted Control Transformer is provided, add the following MCA values to the electrical tables for the system providing power to the transformer: -50, add 5 amps;
2. The minimum recommended disconnect switch is based on 115% of the rated load amps for all loads included in the circuit, per N.E.C. Article 440.12(A)1
3. Minimum fuse size is based upon 150% of the rated load amps for the largest motor plus 100% of the rated load amps for all other loads included in the circuit to avoid nuisance trips at start-up due to lock rotor amps. It is not recommended in applications where brown outs, frequent starting and stopping of the unit, and/or operation at ambient temperatures in excess of 35°C (95°F) is anticipated.
4. Maximum fuse size is based upon 225% of the rated load amps for the largest motor plus 100% of the rated load amps for all other loads included in the circuit, per N.E.C. Article 440.22.

**MULTIPOINT WIRING SYSTEM #2**

CHILLER MODEL	VOLT CODE	TERM BLK	TERMINAL BLK CUSTOMER GROUND	N-F DIS SW	N-F DIS SW CUSTOMER GROUND	CKT.BRKR	CKT.BRKR CUSTOMER GROUND
YCWS0100SB	-17	#2 - 300 KCM	# 6 - 1/0 AWG	#4 - 300 KCM	# 6 - 1/0 AWG	#6 - 350 KCM	# 6 - 1/0 AWG
YCWS0120SB		#2/0 - 500 KCM	# 4 - 3/0 AWG	#6 - 350 KCM	# 6 - 1/0 AWG	250 - 500 KCM	# 4 - 3/0 AWG
YCWS0140SB		#2/0 - 500 KCM	# 4 - 3/0 AWG	#6 - 350 KCM	# 6 - 1/0 AWG	250 - 500 KCM	# 4 - 3/0 AWG
YCWS0180SB		#2/0 - 500 KCM	# 4 - 3/0 AWG	250 - 500 KCM	# 4 - 3/0 AWG	250 - 500 KCM	# 4 - 3/0 AWG
YCWS0200SB		#2/0 - 500 KCM	# 4 - 3/0 AWG	250 - 500 KCM	# 2 - 4/0 AWG	250 - 500 KCM	# 4 - 3/0 AWG
YCWS0220SB		(2) #2-4/0 AWG	(2) # 6 - 1/0 AWG	250 - 500 KCM	# 2 - 4/0 AWG	(2)250 - 500 KCM	(2) # 2 - 4/0 AWG
YCWS0240SB		(2) #2-4/0 AWG	(2) # 6 - 1/0 AWG	(2) #3/0-250 KCM	# 2 - 4/0 AWG	(2)250 - 500 KCM	(2) # 2 - 4/0 AWG
YCWS0100SB	-28	#2 - 4/0 AWG	# 8 - 2 AWG	#4 - 300 KCM	# 6 - 1/0 AWG	#4 - 300 KCM	# 6 - 1/0 AWG
YCWS0120SB		#2 - 300 KCM	# 6 - 1/0 AWG	#4 - 300 KCM	# 6 - 1/0 AWG	#4 - 300 KCM	# 4 - 3/0 AWG
YCWS0140SB		#2 - 300 KCM	# 6 - 1/0 AWG	#4 - 300 KCM	# 6 - 1/0 AWG	#4 - 300 KCM	# 4 - 3/0 AWG
YCWS0180SB		#2/0 - 500 KCM	# 4 - 3/0 AWG	250 - 500 KCM	# 2 - 4/0 AWG	250 - 500 KCM	# 4 - 3/0 AWG
YCWS0200SB		#2/0 - 500 KCM	# 4 - 3/0 AWG	250 - 500 KCM	# 4 - 3/0 AWG	250 - 500 KCM	# 4 - 3/0 AWG
YCWS0220SB		#2/0 - 500 KCM	# 4 - 3/0 AWG	250 - 500 KCM	# 4 - 3/0 AWG	(2)250 - 500 KCM	(2)# 2 - 4/0 AWG
YCWS0240SB		#2/0 - 500 KCM	# 4 - 3/0 AWG	250 - 500 KCM	# 2 - 4/0 AWG	(2)250 - 500 KCM	(2)# 2 - 4/0 AWG
YCWS0100SB	-40	#6 - 1/0 AWG	# 8 - 2 AWG	#14 - 1/0 AWG	# 8 - 2 AWG	#4 - 300 KCM	# 8 - 2 AWG
YCWS0120SB		#2 - 4/0 AWG	# 8 - 2 AWG	#4 - 300 KCM	# 8 - 2 AWG	#4 - 300 KCM	# 6 - 1/0 AWG
YCWS0140SB		#2 - 4/0 AWG	# 8 - 2 AWG	#4 - 300 KCM	# 8 - 2 AWG	#4 - 300 KCM	# 6 - 1/0 AWG
YCWS0180SB		#2 - 4/0 AWG	# 8 - 2 AWG	#4 - 300 KCM	# 6 - 1/0 AWG	#4 - 300 KCM	# 6 - 1/0 AWG
YCWS0200SB		#2 - 4/0 AWG	# 8 - 2 AWG	#4 - 300 KCM	# 6 - 1/0 AWG	#4 - 300 KCM	# 6 - 1/0 AWG
YCWS0220SB		#2 - 4/0 AWG	# 8 - 2 AWG	#4 - 300 KCM	# 6 - 1/0 AWG	#6 - 350 KCM	# 6 - 1/0 AWG
YCWS0240SB		#2 - 300 KCM	# 6 - 1/0 AWG	#4 - 300 KCM	# 6 - 1/0 AWG	#6 - 350 KCM	# 6 - 1/0 AWG
YCWS0100SB	-46	#6 - 1/0 AWG	# 8 - 2 AWG	#14 - 1/0 AWG	# 8 - 2 AWG	#2 - 4/0 AWG	# 8 - 2 AWG
YCWS0120SB		#6 - 1/0 AWG	# 8 - 2 AWG	#4 - 300 KCM	# 8 - 2 AWG	#4 - 300 KCM	# 8 - 2 AWG
YCWS0140SB		#6 - 1/0 AWG	# 8 - 2 AWG	#4 - 300 KCM	# 8 - 2 AWG	#4 - 300 KCM	# 8 - 2 AWG
YCWS0180SB		# 2 - 4/0 AWG	# 8 - 2 AWG	#4 - 300 KCM	# 8 - 2 AWG	#4 - 300 KCM	# 6 - 1/0 AWG
YCWS0200SB		#2 - 4/0 AWG	# 8 - 2 AWG	#4 - 300 KCM	# 8 - 2 AWG	#4 - 300 KCM	# 6 - 1/0 AWG
YCWS0220SB		#2 - 4/0 AWG	# 8 - 2 AWG	#4 - 300 KCM	# 6 - 1/0 AWG	#4 - 300 KCM	# 6 - 1/0 AWG
YCWS0240SB		#2 - 4/0 AWG	# 8 - 2 AWG	#4 - 300 KCM	# 6 - 1/0 AWG	#4 - 300 KCM	# 6 - 1/0 AWG
YCWS0100SB	-58	#18 - 2 AWG	# 8 - 2 AWG	#14 - 1/0 AWG	# 8 - 2 AWG	#14 - 1/0 AWG	# 8 - 2 AWG
YCWS0120SB		#6 - 1/0 AWG	# 8 - 2 AWG	#14 - 1/0 AWG	# 8 - 2 AWG	#2 - 4/0 AWG	# 8 - 2 AWG
YCWS0140SB		#6 - 1/0 AWG	# 8 - 2 AWG	#14 - 1/0 AWG	# 8 - 2 AWG	#2 - 4/0 AWG	# 8 - 2 AWG
YCWS0180SB		#6 - 1/0 AWG	# 8 - 2 AWG	#14 - 1/0 AWG	# 8 - 2 AWG	#4 - 300 KCM	# 8 - 2 AWG
YCWS0200SB		#6 - 1/0 AWG	# 8 - 2 AWG	#4 - 300 KCM	# 8 - 2 AWG	#4 - 300 KCM	# 8 - 2 AWG
YCWS0220SB		#2 - 4/0 AWG	# 8 - 2 AWG	#4 - 300 KCM	# 8 - 2 AWG	#6 - 350 KCM	# 6 - 1/0 AWG
YCWS0240SB		#2 - 4/0 AWG	# 8 - 2 AWG	#4 - 300 KCM	# 8 - 2 AWG	#6 - 350 KCM	# 6 - 1/0 AWG

5. Circuit breakers supplied by third party vendors must be certified by local electrical standards. Maximum size is based on 225% of the rated load amps for the largest motor plus 100% of the rated load amps for all other loads included in the circuit.
6. The "INCOMING WIRE RANGE" is the minimum and maximum wire size that can be accommodated by the unit wiring lugs. The (2) preceding the wire range indicates the number of termination points available per phase of the wire range specified. Actual wire size and number of wires per phase must be determined based on the National Electrical Code, using copper connectors only. Field wiring must also comply with local codes.
7. A ground lug is provided for each compressor system to accommodate a field grounding conductor per N.E.C. Table 250.122. A control circuit grounding lug is also supplied.
8. The supplied disconnect is a "Disconnecting Means" as defined in the N.E.C. 100.I, and is intended for isolating the unit for the available power supply to perform maintenance and troubleshooting. This disconnect is not intended to be a Load Break Device.
9. Field Wiring by others which complies to the National Electrical Code & Local Codes.

# Customer Wiring Data

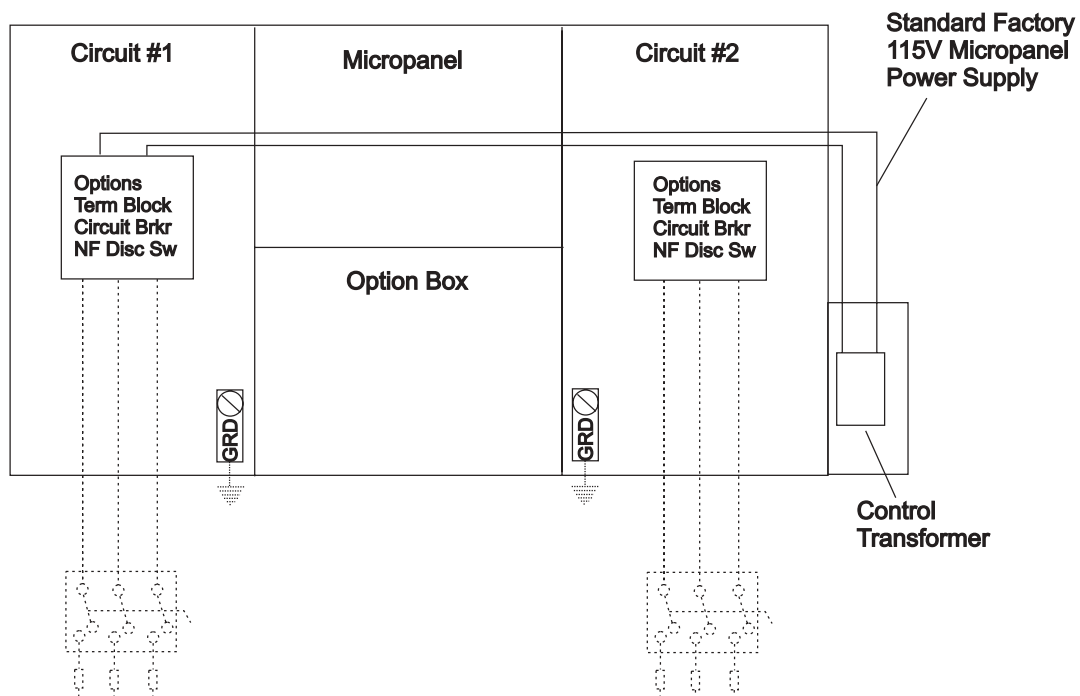

FIGURE 9 - MULTIPOINT POWER SUPPLY CONNECTION - STANDARD UNIT

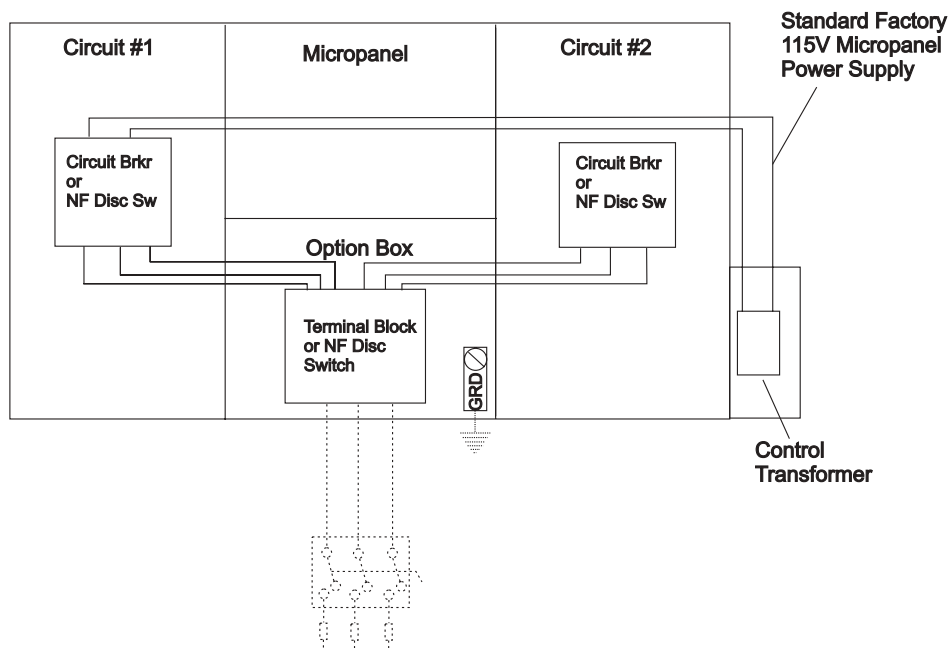
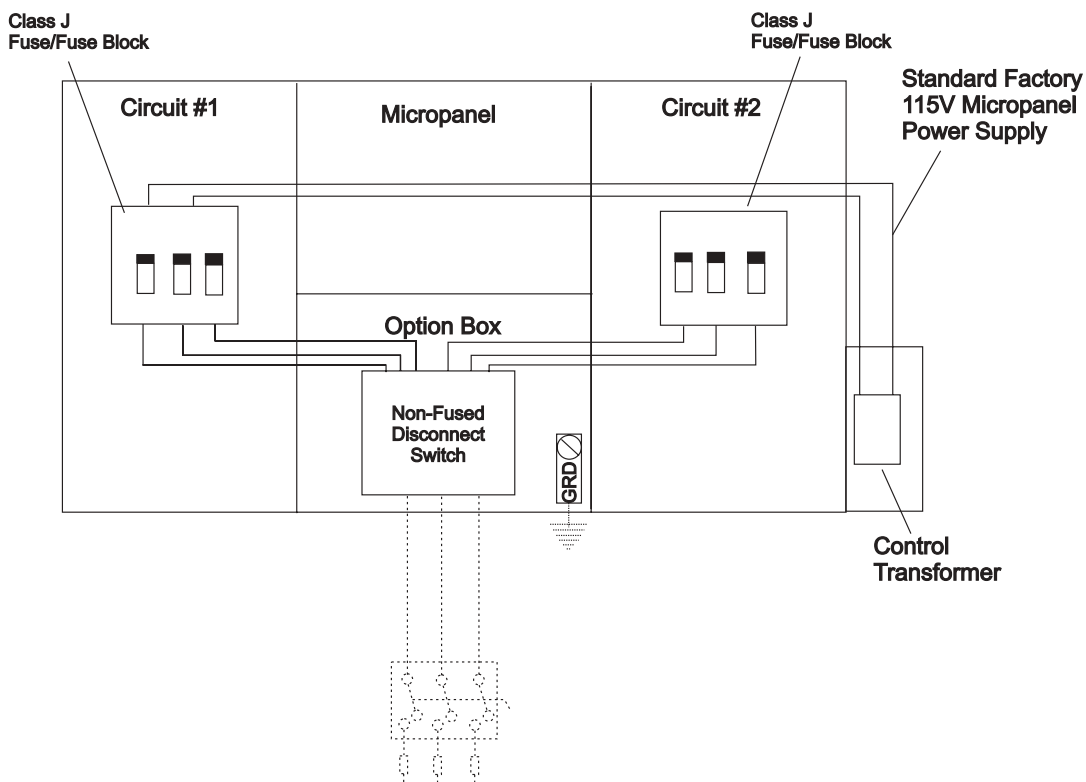

FIGURE 10 - SINGLE POINT POWER SUPPLY WITH INTERNAL CIRCUIT BREAKER OR NON-FUSED DISCONNECT SWITCH



**FIGURE 11 - OPTIONAL SINGLE POINT POWER SUPPLY WITH INTERNAL CLASS J FUSES/BLOCK**

**Notes:**

1. Dashed line indicates field provided wiring
2. The above recommendations are based upon the National Electric Code and the use of copper connectors only.  
Field wiring must comply with local codes.
3. Single point Non-Fused Disconnect Switch is not offered with additional separate Non-Fused Disconnect Switches

**VOLTAGE CODE**

- 17 = 200-3-60
- 28 = 230-3-60
- 40 = 380-3-60
- 46 = 460-3-60
- 58 = 575-3-60

**LEGEND**

TERM BLOCK	TERMINAL BLOCK (FACTORY MOUNTED)
C.B.	CIRCUIT BREAKER (FACTORY MOUNTED)
NF DISC SW	NON-FUSED DISCONNECT SWITCH (FACTORY MOUNTED)
D.F.	DUAL FUSE
DISC	SW DISCONNECT SWITCH
HZ	HERTZ
MAX	MAXIMUM
MCA	MINIMUM CIRCUIT AMPACITY
MIN	MINIMUM
MIN NF	MINIMUM NON FUSED
RLA	RATED LOAD AMPS
Y-D LRA	WYE-DELTA INRUSH LOCKED ROTOR AMPS

# Typical Control Panel Wiring

## LEGEND

TS



TRANSIENT VOLTAGE SUPPRESSION  
TERMINAL BLOCK FOR CUSTOMER  
CONNECTIONS. -XCCTB



TERMINAL BLOCK FOR CUSTOMER LOW VOLTAGE  
(CLASS 2) CONNECTIONS. SEE NOTE 2. -XT1B1



TERMINAL BLOCK FOR YORK  
CONNECTIONS ONLY



WIRING AND COMPONENTS BY YORK



OPTIONAL EQUIPMENT



WIRING AND/OR COMPONENTS BY OTHERS

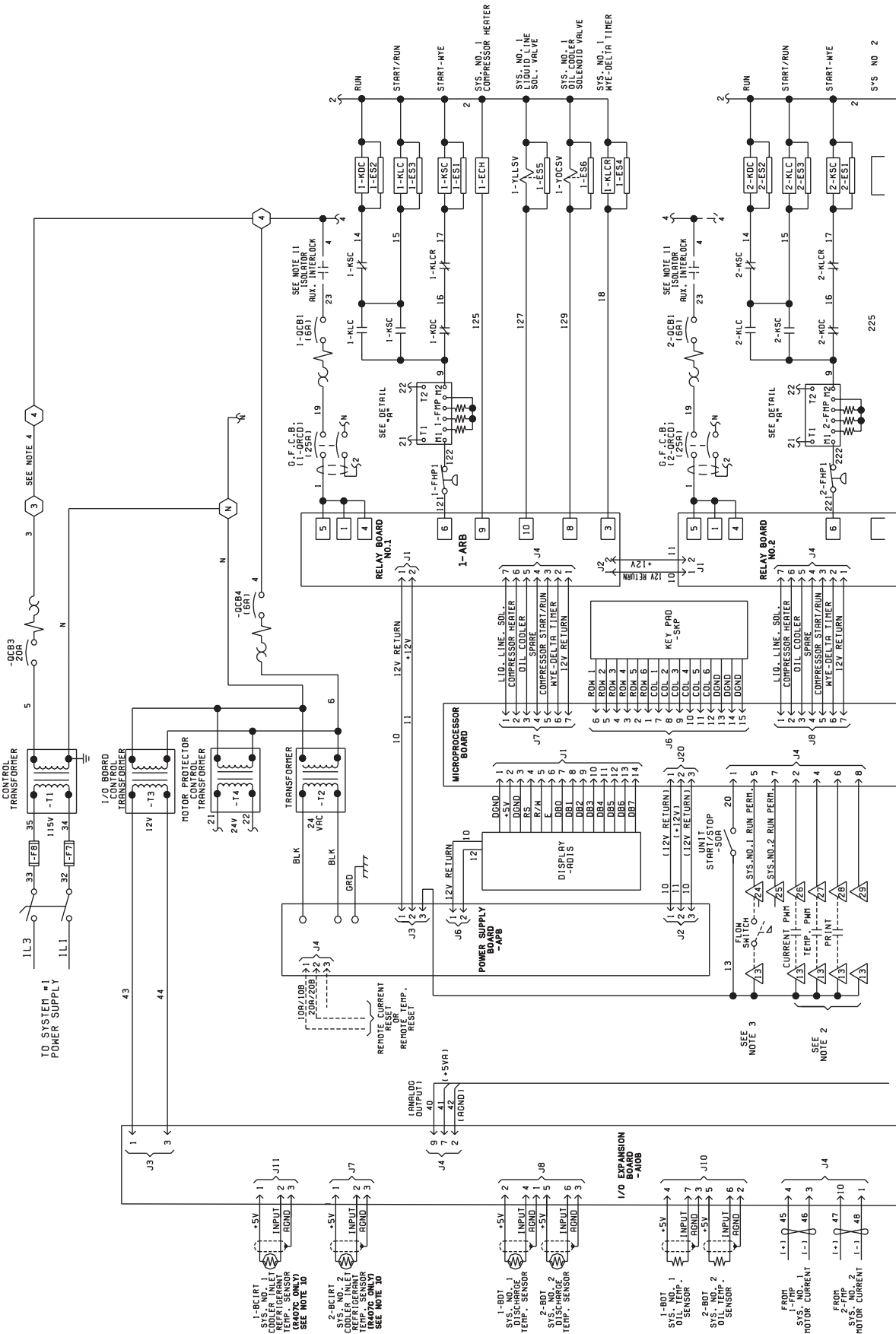



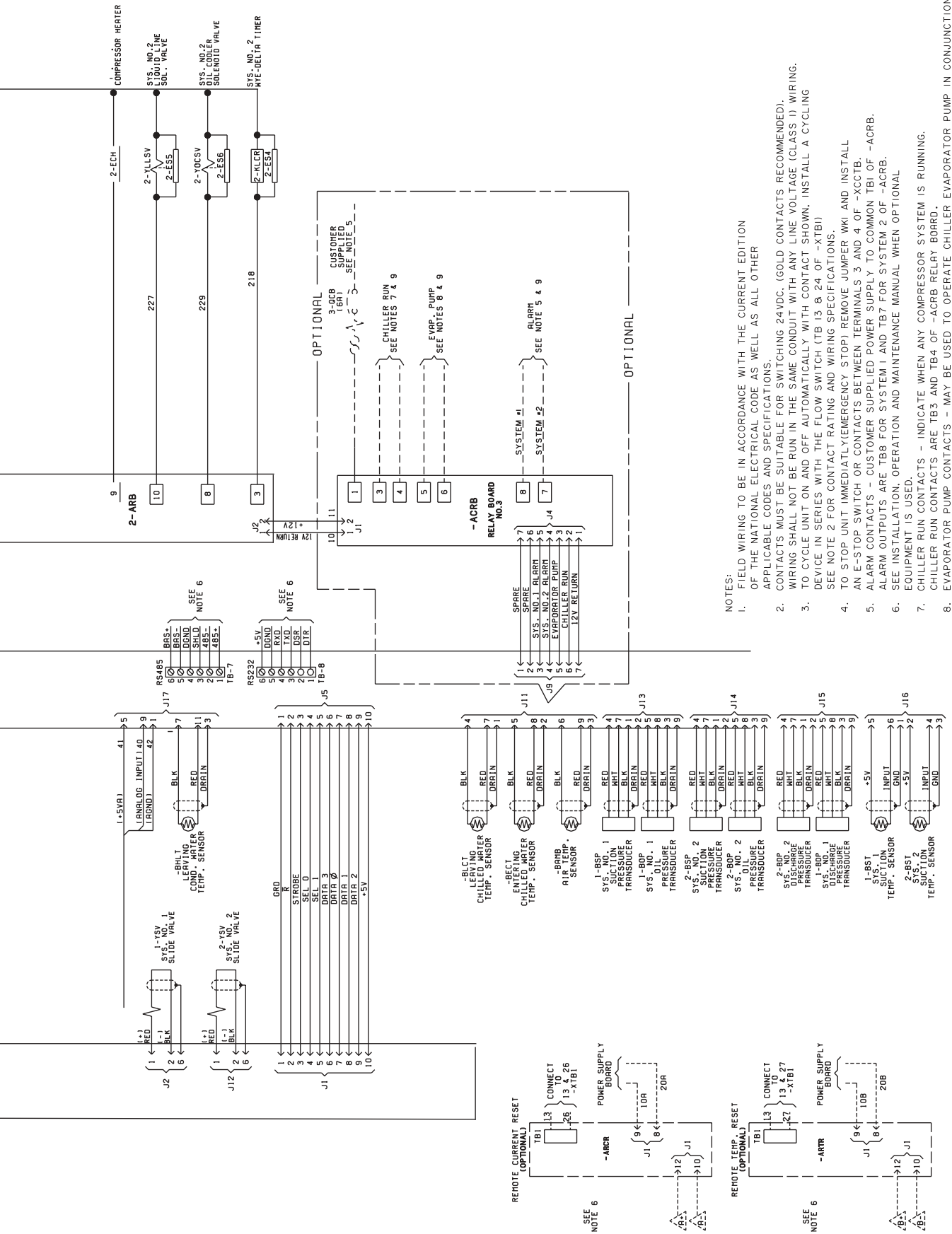

- NOTES:
- FIELD WIRING TO BE IN ACCORDANCE WITH THE CURRENT EDITION OF THE NATIONAL ELECTRICAL CODE AS WELL AS ALL OTHER APPLICABLE CODES AND SPECIFICATIONS.
  - CONTACTS MUST BE SUITABLE FOR SWITCHING 24VDC. (GOLD CONTACTS RECOMMENDED).
  - WIRING SHALL NOT BE RUN IN THE SAME CONDUIT WITH ANY LINE VOLTAGE (CLASS 1) WIRING. TO CYCLE UNIT ON AND OFF AUTOMATICALLY WITH CONTACT SHOWN, INSTALL A CYCLING DEVICE IN SERIES WITH THE FLOW SWITCH (TB 13 & 24 OF -XTBI) SEE NOTE 2 FOR CONTACT RATING AND WIRING SPECIFICATIONS.
  - AN E-STOP SWITCH OR CONTACTS BETWEEN TERMINALS 3 AND 4 OF -XCCTB TO STOP UNIT IMMEDIATELY (EMERGENCY STOP) REMOVE JUMPER WK1 AND INSTALL ALARM CONTACTS - CUSTOMER SUPPLIED POWER SUPPLY TO COMMON TB1 OF -ACRFB.
  - ALARM OUTPUTS ARE TB8 FOR SYSTEM 1 AND TB7 FOR SYSTEM 2 OF -ACRFB. SEE INSTALLATION, OPERATION AND MAINTENANCE MANUAL WHEN OPTIONAL EQUIPMENT IS USED.
  - CHILLER RUN CONTACTS - INDICATE WHEN ANY COMPRESSOR SYSTEM IS RUNNING. CHILLER RUN CONTACTS ARE TB3 AND TB4 OF -ACRFB RELAY BOARD.
  - EVAPORATOR PUMP CONTACTS - MAY BE USED TO OPERATE CHILLER EVAPORATOR PUMP IN CONJUNCTION WITH OTHER CONTROLS. EVAPORATOR PUMP CONTACTS ARE TB5 & TB6 OF -ACRFB RELAY BOARD.
  - CONTACTS ARE RATED FOR 15VAC, 100VA RESISTIVE LOAD ONLY. LOAD MUST BE SUPPRESSED AT SOURCE BY USER.
  - COOLER INLET REFRIGERANT SENSORS FITTED ONLY ON R-407C CHILLERS.
  - WHEN ISOLATOR IS NOT INSTALLED (OPTIONAL EQUIPMENT) A JUMPER IS INSTALLED TO COMPLETE THE CIRCUIT.

# Application Data

## UNIT LOCATION

Chillers may be placed on the ground floor or upper floor of the building. The floor must be level and capable of supporting 150% of the operating weight of the unit. Units should be located away from noise-critical areas. Service clearance must be allowed and include space for removing cooler or condenser tubes. A doorway or window can sometimes provide space for tube removal. Units should be installed indoors where they are not exposed to rain or water splash. Chillers should be located near a drain. The use of chillers in corrosive, dusty or explosive atmospheres should be avoided unless the unit is properly protected. A unit located in a clean room will run best, require least maintenance, and last longest. Heat or ventilation may be required to maintain the ambient between 40°F and 115°F (4.4°C and 46.1°C).

## UNIT ISOLATION

The chiller foundation must be rigid to reduce vibration transmission to a minimum. All upper story installations should use vibration isolators under the unit base. To maintain isolator efficiency, no mechanical ties should be made to the building. Properly selected flexible connectors and piping isolators are recommended. All the above recommendations will help to reduce vibration transmission and result in a quieter operation.

## FIELD CONNECTED WATER PIPING

must comply in all respects with applicable local plumbing codes and ordinances. In no case should the unit support the weight of connecting piping. Since elbows, tees, and valves increase pressure drop, all piping should be kept as simple as possible. Hand stop valves should be installed where required to facilitate servicing. Piping to the inlet and outlet connections of the cooler and condenser may include high-pressure rubber hose or piping loops to ensure against water pump transmission of vibration.

Facilities should be provided for measuring temperature and pressure in the cooler and condenser field water piping. Drain connections should be provided at all low points to permit complete drainage of the cooler(s), condenser(s), and system piping. This is especially important if the unit is located in an unheated room where freezing could prevail. Water lines subjected to ambient temperatures below freezing may require heater cables or antifreeze (by others).

Water loops should contain provisions for venting. A strainer, preferably 40 mesh, should be installed in the cooler and condenser inlet lines, and located where it will protect the circulating pump and the heat exchanger tube bundles. It should be determined that the maximum water pressure at the cooler or condenser does not ex-

ceed the maximum design working pressure of the cooler or condenser.

The water circulating pumps should be located on the inlet side of the heat exchangers. If, however, space does not permit this, the pumps may be located in the outlet water piping. The net positive suction head must be considered when applying pumps.

## PARALLEL CHILLER APPLICATION

Multiple chillers are often used to provide increased reliability, reserve capacity, or to divide the design capacity. The standard factory packaged chiller is most compatible with parallel chilled liquid flow. Series flow arrangements are less desirable for pre-engineered packaged units due to excessive chilled liquid flow rate and higher pressure drops. YORK recommends that standard package chillers be arranged for parallel chilled liquid flow.

## FIELD WIRING

All field wiring must comply with the National Electric Code and all applicable local codes. YORK liquid chiller units are factory wired for optimum reliability. Therefore the unit controls must not be modified without expressed written consent by YORK. The use of a simple switch or timer from a remote point is permitted; but it must be connected to the YORK unit panel at points expressly indicated for that purpose.

# Guide Specifications

YORK Model YCWS \_\_\_\_\_ Packaged Chiller(s). The (each) unit shall have a cooling capacity of \_\_\_\_\_ tons with Compressor kW when cooling GPM of water from \_\_\_\_\_ °F (°C) to \_\_\_\_\_ °F (°C) and with \_\_\_\_\_ GPM of condensing water entering at \_\_\_\_\_ °F (°C) and leaving at \_\_\_\_\_ °F (°C), and a cooler fouling factor of \_\_\_\_\_ and condenser water fouling factor of \_\_\_\_\_. The water pressure drop shall not exceed \_\_\_\_\_ feet (kPa) of water through the cooler and \_\_\_\_\_ feet (kPa) of water through the condenser. The unit overall dimensions shall not exceed \_\_\_\_\_ feet (mm) \_\_\_\_\_ ins. in length, \_\_\_\_\_ feet (mm) \_\_\_\_\_ ins. in width and \_\_\_\_\_ feet (mm) \_\_\_\_\_ in height. The unit operating weight shall not exceed \_\_\_\_\_ lbs. (Kg).

## GENERAL

The (Each) Packaged Water Cooled Screw Chiller shall be completely factory assembled (in an ISO 9001 registered facility) including all interconnecting refrigerant piping and internal wiring of controls, mounted on a steel base which accommodates the condenser, compressor(s) and evaporator.

There will be an operational test, with water flowing through the cooler, to check that each control device operates correctly. The chiller will be shipped with 10 lbs of HFC-407C refrigerant and York 'L' (POE) synthetic oil.

Unit shall be offered with an optional overspray painted Caribbean Blue enamel finish.

The unit shall contain two separate refrigerant circuits, each with a single compressor for standby operation. All units shall be designed and constructed in accordance with the applicable sections of the following: American Society of Heating, Refrigeration and Air Conditioning Engineers ANSI/ASHRAE 15 Safety Code for Mechanical Refrigeration; American Society of Mechanical Engineers ASME Pressure Vessel Code; National Electrical Code/National Fire Protection Association NFPA 70. The unit shall be produced at an ISO 9001 registered facility. All chillers are rated in accordance with ARI Standard 550/590.

## COMPRESSORS

Compressors shall be direct drive, semi-hermetic, rotary twin-screw type, including: internal muffler, temperature actuated, off-cycle heater, terminal box, internal discharge check, discharge and suction shutoff service valves, and precision machined cast iron housing. Design working pressure of entire compressor, suction to discharge, shall be 31 bar (450psig).

Motors shall feature refrigerant suction-gas cooled two-

pole accessible hermetic compressor motor, full suction gas flow through a mesh screen, with inherent internal thermal overload protection and external current overload on all three phases. Motor stator shall employ APT2000 type magnet wire.

Lubrication shall feature external oil separators with no moving or fragile parts, 31 bar (450psig) design working pressure, and UL listing. Refrigerant system differential pressure shall provide oil flow through service replaceable, 0.5 micron, full flow, cartridge type oil filter internal to compressor. Filter bypass, less restrictive media, or oil pump not acceptable.

Compressors shall start at minimum load position. Capacity control range from 100% to 10% of chiller full load using continuous function slide valves, and without hot gas bypass. Step unloading unacceptable. Provide Microprocessor controlled, output pressure regulating capacity control valve to command compressor capacity independent of control valve input pressure and balance compressor capacity with cooling load.

## CAPACITY CONTROL SYSTEM

Continuous function, microprocessor controlled, 3- way proportional Capacity Control Valve provides regulated output pressure independent of valve input pressure for a stable, smooth, and precise match of compressor capacity to cooling load to 10% of chiller capacity.

## COOLER

The cooler shall be a direct expansion shell and tube type with refrigerant in the tubes and liquid to be chilled in the shell. The design working pressure of the cooler shell (liquid) side shall be 150 PSIG for the tube (refrigerant) side. Refrigerant heads shall be removable. The cooler shall be covered with 3/4" flexible closed cell foam insulation (K = 0.25 maximum) to prevent sweating. The cooler shall be constructed and tested in accordance with ASME Code requirements. Vent and drain connections shall be included. The water connections shall be fully accessible and grooved to accept victaulic couplings if used (by others).

## CONDENSER

The condenser is a cleanable thru-tube with steel shell, copper tubes, removable water heads and includes integral subcooling. Refer to PHYSICAL DATA for design working pressures. The shell will be constructed and tested in accordance with section VIII, division 1 of ASME pressure-vessel code. The condenser is equipped with relief valves and will hold the full refrigerant charge for pumpdown.

# Guide Specifications - Cont.

---

## REFRIGERANT CIRCUITS

Two independent refrigerant circuits will be furnished on each unit. All piping will be ACR copper with brazed joints. The liquid line will include: a shutoff valve with charging port; sightglass with moisture indicator; thermal expansion valve; solenoid valve; and high-absorption removable-core filter drier. The entire suction line and the liquid line between the expansion valve and the cooler will be insulated with flexible, closed-cell, foam insulation.

## MICROCOMPUTER CONTROL CENTER

Each unit shall contain a Microcomputer Control Center. All logic and controls shall be contained within a IP 32 (NEMA 1) cabinet with hinged outer door with positive acting latches. Inside shall be contained the "user friendly" and interactive inputs and outputs as follows: LCD display with light emitting diode back lighting for easy viewing of data and input buttons for DISPLAY (temperatures, pressure, etc.). ENTRY (enter/cancel inputs, advance day, change AM/PM), SETPOINTS (change), CLOCK (set time and schedule), PRINT (calling up operating and shutdown data), PROGRAM (change inputs from special conditions such as brine chilling) and UNIT ON/OFF.

The Microcomputer Control Center shall be capable of displaying the following: return and leaving liquid temperature; return and leaving condenser water temperature (optional); low leaving liquid temperature cutout setting; system 1 and 2 percent full-load motor current and suction, discharge (optional) and oil differential pressures; liquid pulldown control range (selectable for 0.6°C to 1.1°C [1°F to 2°F] in one-tenth increments above the set-

point); liquid pulldown rate sensitivity (0.3°C to 3.0°C [0.5°F to 5°F]/minute in 0.05°C [0.1°F] increments); anti-recycle timer status; compressor run status; no cooling load condition; day; date; time; out of range message; daily and holiday scheduling of start/stop times; automatic or manual lead/lag status; lead compressor definition; number of compressor starts and running hours; status of hot gas bypass valves (option), liquid line solenoid valves, and water pump; last three fault shutdowns data; number of unloading steps; compressor load and unload timer status.

The operating program shall be stored in nonvolatile memory (EPROM) to eliminate chiller failure due to AC power failure/battery discharge. Programmed setpoints are retained in lithium battery – backed RTC memory for 5 years minimum.

Provisions shall be included for: pumpdown at shutdown and recycling pumpdown; a hard copy printout from a printer (by others) via an RS-232 electrical output; two steps of demand load limiting and remote chilled liquid reset from an external building automation system; unit alarm contacts; chilled water pump or remote air-cooled condenser control; or Remote Control with printout capability (up to 2000 feet) via an RS-485 electrical output.

## POWER PANEL

The power panel shall contain the compressor power terminals. U.L. recognized compressor motor starting contactors which meet I.E.C. requirements, current transformer sensing for each compressor power source, for protection against under current, over current, imbalanced current, single phasing compressor stall and voltage spikes.









P.O. Box 1582, York, Pennsylvania USA 17405-1522  
Copyright © by York International Corporation 2001  
Form 201.24-EG1 (1001)  
New Release

Tel: 800-861-1001  
[www.york.com](http://www.york.com)

Subject to change without notice. Printed in USA  
ALL RIGHTS RESERVED  
RPC 3M 1001 4.48  
Codes: DXS, ET