



Heating and Air Conditioning

TECHNICAL GUIDE

SINGLE PACKAGE GAS/ELECTRIC UNITS

AND SINGLE PACKAGE

AIR CONDITIONERS

DF 072

6 NOMINAL TONS

10.4 EER

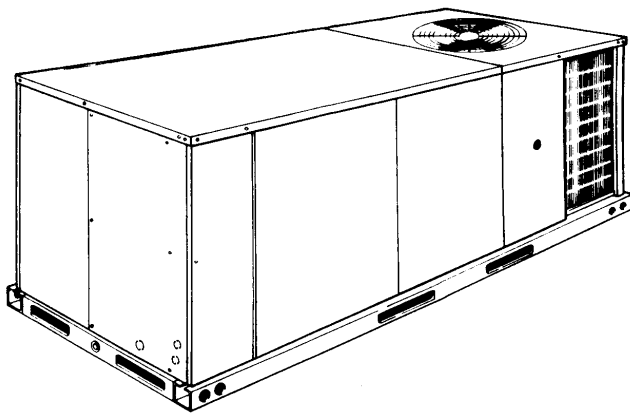

DESCRIPTION

YORK® Sunline Plus™ units are convertible single package air conditioners. The units were designed for light commercial and commercial applications. They can easily be installed on a roof curb, slab, roof jack or frame.

All units include:

- Powder Paint finish that meets ASTM-B-117 1000 hour salt spray standards
- Permanently lubricated motors
- Bottom or side air discharge configuration capability (field convertible)
- Manufactured under the quality standards of ISO9001
- **Simplicity**® Control Board
- Copper tube/aluminum fin coils
- Easy access to all components
- Rigging holes in base rails for lifting
- Fork lift slots on three sides
- Single point power connection
- Complete factory package - tested, charged and wired
- CSA agency listing on all units

WARRANTY

- Factory Limited Parts Warranty
- One-year parts warranty
- A Five-year parts warranty on the compressor and electric heat elements.
- Ten-year parts warranty on the gas-fired heat exchangers.



TABLE OF CONTENTS

DESCRIPTION 1

PRODUCT NOMENCLATURE 3

FEATURES 4

FACTORY-INSTALLED OPTIONS 5

FIELD-INSTALLED ACCESSORIES 7

GUIDE SPECIFICATIONS 21

LIST OF FIGURES

<u>Fig. #</u>	<u>Pg. #</u>
1	5
2	15
3	16
4	16
5	17
6	17
7	18
8	18
9	19
10	20
11	21

LIST OF TABLES

<u>Tbl. #</u>		<u>Pg. #</u>
1	SOUND POWER RATING	8
2	CAPACITY RATINGS - (ARI 210/240)	8
3	GAS HEAT RATINGS	8
4	2 STAGE GAS HEAT RATINGS	8
5	DF072 COOLING CAPACITIES (6 TON)	9
6	SUPPLY AIR BLOWER PERFORMANCE (6 TON BELT DRIVE) - SIDE DUCT APPLICATION	10
7	BELT DRIVE BLOWER MOTOR AND DRIVE DATA	10
8	SUPPLY AIR BLOWER PERFORMANCE (6 TON BELT DRIVE) - SIDE DUCT APPLICATION	11
9	STATIC RESISTANCES	11
10	ELECTRIC HEATER CFM LIMITATIONS	11
11	ELECTRICAL DATA - DF072 BELT DRIVE W/O POWERED CONV. OUTLET	12
12	ELECTRICAL DATA - DF072 DIRECT DRIVE W/O POWERED CONV. OUTLET	12
13	ELECTRICAL DATA - DF072 BELT DRIVE W/POWERED CONV. OUTLET	13
14	ELECTRICAL DATA - DF072 DIRECT DRIVE W/POWERED CONV. OUTLET	13
15	DF PHYSICAL DATA	14
16	ELECTRIC HEAT CORRECTION FACTORS	14
17	VOLTAGE LIMITATIONS	14
18	UTILITIES ENTRY	18
19	MINIMUM CLEARANCES	18
20	DF 4 AND 6 POINT LOADS WEIGHT DISTRIBUTION	20
21	CENTER OF GRAVITY	20
22	DF OPERATING WEIGHTS (LBS.)	20

PRODUCT NOMENCLATURE

6 Ton Sunline Model Number Nomenclature

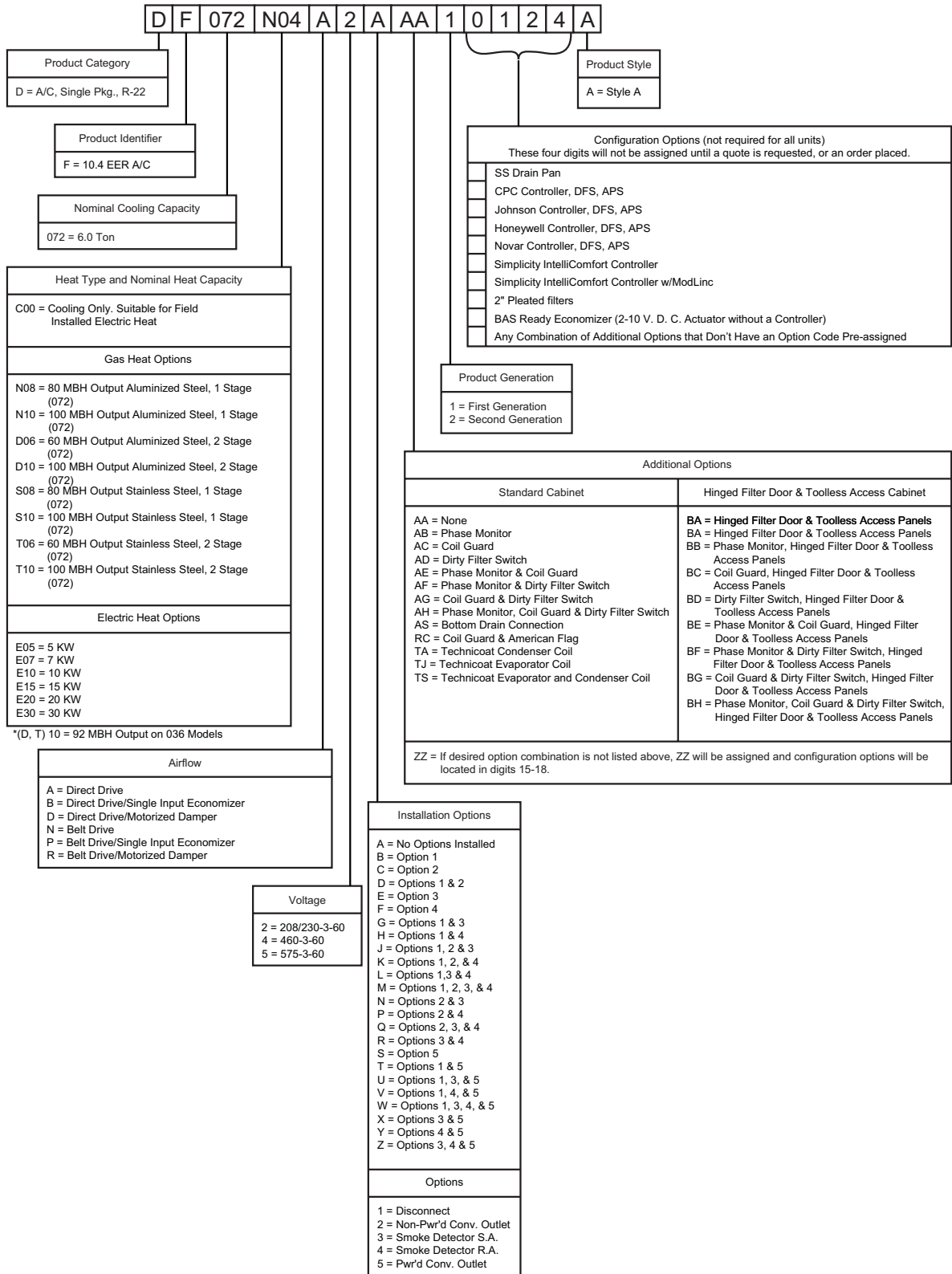

FEATURES

All models are available with a wide variety of factory-mounted options such as stainless steel heat exchangers, electric heaters, phase monitor, convenience outlet, dirty filter switch, disconnect switch, smoke detectors, and coil guard to make them suitable for almost every application.

All units are self-contained and assembled on full perimeter base rails with forklift holes on three sides and holes for overhead rigging. Every unit is completely piped, wired, charged and tested at the factory to simplify the field installation and to provide years of dependable operation.

All models (including those with an economizer) are suitable for either bottom or horizontal duct connections. For bottom duct, remove the sheet metal panels from the supply and return air openings through the base of the unit. For horizontal duct, remove the supply and return air panels on the rear of the unit.

All models are available with these “factory mounted” outdoor air damper options:

- Single enthalpy economizer
- Motorized outdoor air damper

Supply air blowers are equipped with either a direct drive or a belt drive that can be adjusted to meet the exact requirements of the job.

All compressors are equipped with internal pressure relief. Every refrigerant circuit includes a liquid line filter-drier, a high pressure switch and a suction line with a freeze-stat and low pressure/loss of charge switch to protect all system components.

- **Simplicity® Controls - Simplicity®** control boards have standardized a number of features previously available only as options or by utilizing additional controls.
 - **Low Ambient** - An integrated low-ambient control allows all units to operate in the cooling mode down to 0°F outdoor ambient without additional assistance. Optionally, the control board can be programmed to lockout the compressors when the outdoor air temperature is low or when free cooling is available.
 - **Anti-Short Cycle Protection** - To aid compressor life, an anti-short cycle delay is incorporated into the standard controls. Compressor reliability is further ensured by programmable minimum run times. For testing, the anti short cycle delay can be temporarily overridden with the push of a button.
 - **Fan Delays** - Fan on and fan off delays are fully programmable and are independent of one another. All units are programmed with default values based upon their configuration of cooling and heat.
 - **Safety Monitoring** - The control board monitors the high and low-pressure switches, the freeze-stats, the

gas valve, if applicable, and the temperature limit switch on gas heat units. The unit control board will alarm on ignition failures, compressor lockouts and repeated limit switch trips.

- **Nuisance Trip Protection**- To prevent nuisance trouble calls, the control board uses a “three strikes, you’re out” philosophy. The high and low-pressure switches and the freeze-stats must trip three times within two hours before the unit control board will lock out the compressor.
- **On Board Diagnostics** - Each alarm will energize a trouble light on the thermostat, if so equipped, and flash an alarm code on the control board LED. Each high and low-pressure switch alarm as well as each freeze-stat alarm has its own flash code. The control board saves the five most recent alarms in memory, and these alarms can be reviewed at any time. Alarms and programmed values are retained through the loss of power.

All units have long lasting powder paint cabinets with 1000 hour salt spray test approval under ASTM-B117 procedures.

All models are CSA listed.

- **Warranty** - All models include a one-year limited parts warranty on the complete unit. Compressors and electric heater elements carry a five-year warranty. Gas heat exchangers carry a 10-year parts warranty.
- **Gas Heat Operation** - All single phase models with gas heat have minimum annual fuel utilization efficiency (AFUE) of 80%. All three phase models with gas heat have minimum steady state efficiency of 80%. Each section includes a durable heat exchanger with aluminized steel or optional stainless steel tubes, a redundant gas valve, spark ignition, power venting, an ignition module for 100% shut-off and all of the safety controls required to meet the latest ANSI standards.

The gas supply piping can be routed into the heating compartment through a hole in the base pan of the unit or through a knockout in the piping panel on the front of the unit.

- **Electric Heat Operation** - All electric heat models are wired for a single power source and include a bank of nickel chromium elements mounted at the discharge of the supply air blower to provide a high velocity and uniform distribution of air across the heating elements. Every element is fully protected against excessive temperature by thermal limit switches.

The power supply wiring can be routed into the control box through a threaded pipe connection (field supplied) in the base pan of the unit or through a knockout in the wiring panel on the side of the unit.

- **BAS Controls** - York’s Sunline™ series units offer factory mounted BAS controls such as Simplicity® INTELLI-Comfort™, Novar, Honeywell, Johnson, and CPC.

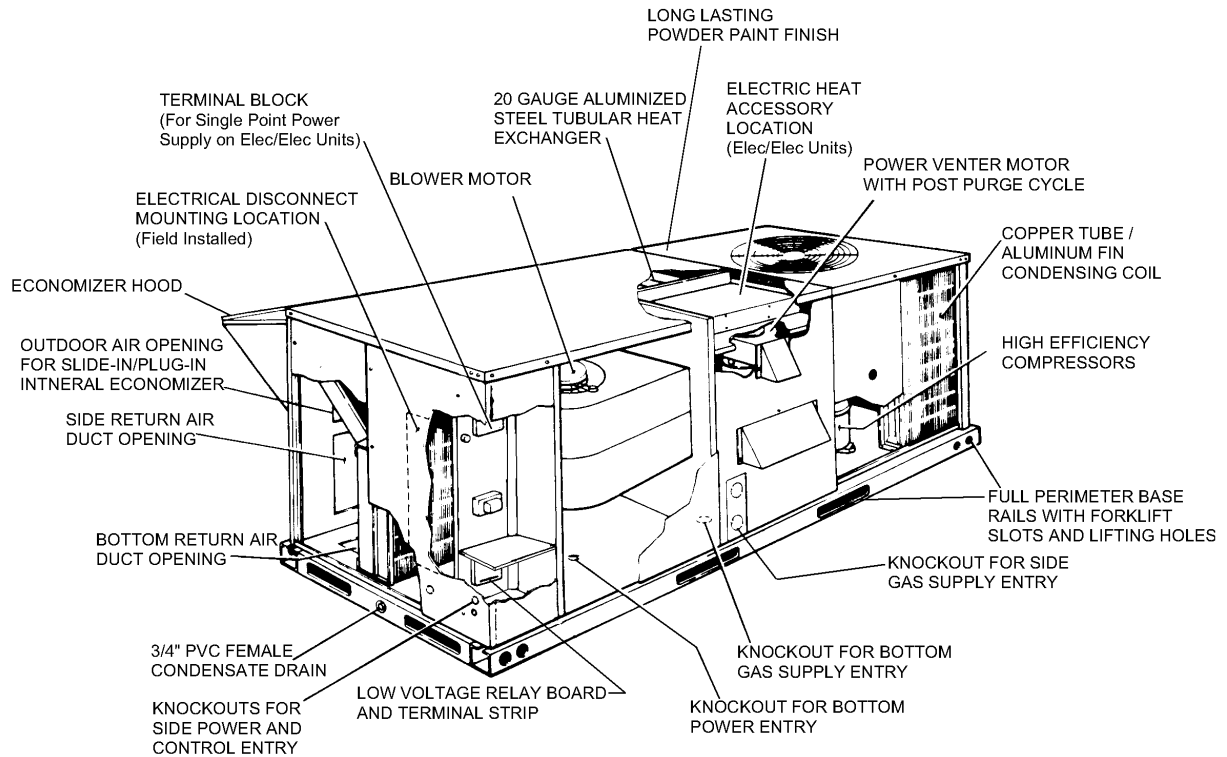

FIGURE 1 - UNIT CUTAWAY

FACTORY-INSTALLED OPTIONS

- **SINGLE INPUT ELECTRONIC ENTHALPY ECONOMIZERS** - Includes a slide-in / plug-in damper assembly with fully modulating spring-return motor actuator capable of introducing up to 100% outdoor air with nominal 1% leakage type dampers.

The enthalpy system contains one sensor that monitors the outdoor air and determines when the air is cool enough and dry enough to provide free cooling.

The rainhood is painted to match the basic unit and must be field-assembled before installing.

- **MOTORIZED OUTDOOR AIR INTAKE DAMPER** - Includes a slide-in / plug-in damper assembly with a 2-position, spring return motor actuator which opens to a pre-set position whenever the supply air blower is operating and will drive fully closed when the blower unit shuts down.
The rain hood is painted to match the basic unit and must be field assembled before installing.
- **PHENOLIC COATED EVAPORATOR AND CONDENSER COILS** - Special coating process that utilizes Technicoat 10-1™ processes. Coating is applied by total immersion of the complete coil for maximum protection.

- **ELECTRIC HEATERS** - Wired for single point power supply. These nickel chromium heater elements are provided with limit and automatic reset capability to prevent operation at excessive temperatures.
- **FILTER OPTIONS** - Standard units are shipped with 1" throw-away filters installed. 2" pleated filters are offered as a factory installed option.
- **CONVENIENCE OUTLET** - This 110 volt outlet can be "powered" by the unit with a stepdown transformer or the unit may be ordered with a "non-powered" convenience outlet that can be wired in the field.
- **DISCONNECT SWITCH** - For gas heat units and cooling units with electric heat, a HACR breaker sized to the unit is provided. For cooling only units, a switch sized to the largest electric heat available for the particular unit is provided. Factory installed option only.
- **BAS - Building Automation System Controls**
Simplicity® INTELLI-Comfort™ CONTROL - The York® Simplicity® INTELLI-Comfort™ control is factory installed. It includes a supply air sensor, a return air sensor, and an outside air sensor. There are provisions for a field installed dirty filter indicator switch, an air-proving switch, an Outside Air Humidity sensor, a Return Air Humidity sensor, an Inside IAQ sensor, and an Outside Air IAQ sensor. Construction mode operation, 365-day real time clock with 7 day programming plus holiday

scheduling is built-in. Two different modes of demand ventilation are achieved through the INTELLI-Comfort™ using CO2 sensors. It uses an inside CO2 sensor to perform Demand Ventilation. It can also use an Outside CO2 sensor to perform Differential Demand Ventilation. It uses a Patented Comfort Ventilation algorithm to provide comfortable ventilation air temperature. The patented economizer-loading algorithm will protect the equipment when harsh operating conditions exist. Humidity in the occupied space or return duct can be monitored and controlled via humidity sensors and the on-board connection for hot gas re-heat system. It uses the INTELLI-Start™ algorithm to maximize energy savings by recovering the building from the Unoccupied Setpoints to the Occupied Setpoints just in time for the Occupied Time Period to begin. The Simplicity® INTELLI-Comfort™ balances space temperature, ventilation air temperature, CO2 and humidity for ultimate comfort.

- **Simplicity® INTELLI-Comfort™ with MOD LINK CONTROL** - The York® Simplicity® INTELLI-Comfort™ with Mod Link control is factory installed. It includes all the features of the INTELLI-Comfort™ control with an additional control to translate communications from MOD-BUS to the BACnet MSTP protocol.
- **Novar® BAS CONTROL** - The Novar® ETC-3 building automation system controller is factory installed. Includes supply air sensor, return air sensor, dirty filter indicator switch, and air proving switch.
- **JOHNSON CONTROLS BAS CONTROL** - The Johnson Control YK-UNT-1126 building automation system controller is factory installed. Includes supply air sensor, return air sensor, dirty filter indicator switch, and air proving switch.
- **CPC BAS CONTROL** - The Computer Process Controls Model 810-3060 ARTC Advanced Rooftop building automation system controller is factory installed. Includes supply air sensor, return air sensor, dirty filter indicator switch and air proving switch.
- **HONEYWELL BAS CONTROL** - The Honeywell W7750C building automation system controller is factory installed. Includes air supply sensor, return air sensor, dirty filter indicator switch, and air proving switch.
- **SMOKE DETECTORS** - (supply air & return air) The smoke detectors stop operation of the unit by interrupting

power to the control board if smoke is detected within the air compartment.

▲ WARNING

Factory installed Smoke Detectors in the return air, may be subjected to freezing temperatures during “off” times due to outside air infiltration. These smoke detectors have an operational limit of 32°F to 131°F. Smoke detectors installed in areas that could be outside those limitations will have to be moved to prevent having false alarms.

- **COIL GUARD** - Customers can purchase a coil guard kit to protect the condenser coil from damage. This is not a hail guard kit.
 - **STAINLESS STEEL HEAT EXCHANGER** - For applications in corrosive environments, this option provides a full stainless steel heat exchanger assembly.
 - **STAINLESS STEEL DRAIN PAN** - An optional rust-proof stainless steel drain pan is available to provide years of trouble-free operation in corrosive environments.
 - **BOTTOM DRAIN CONNECTION** - An optional bottom drain connection is available for inside the curb connections for applications in cold environments to reduce freezing drain lines.
 - **PHASE MONITORS** - Designed to prevent unit damage. The phase monitor will shut the unit down in an out-of-phase condition.
 - **DIRTY FILTER SWITCH** - This kit includes a differential pressure switch that energizes the fault light on the unit thermostat, indicating that there is an abnormally high pressure drop across the filters. Factory installed option or field installed accessory.
 - **HINGED FILTER DOOR/“TOOLLESS” BLOWER AND ACCESS PANELS** (not hinged) - This option allows for easy access and maintenance.
- NOTE:** Knobs are shipped inside the unit to prevent shipping damage. These must be field installed for tool-less operation.

FIELD-INSTALLED ACCESSORIES

- **SINGLE INPUT ELECTRONIC ENTHALPY ECONOMIZERS** - Includes a slide-in / plug-in damper assembly with fully modulating spring-return motor actuator capable of introducing up to 100% outdoor air with nominal 1% leakage type dampers.

The enthalpy system contains one sensor that monitors the outdoor air and determines when the air is cool enough and dry enough to provide free cooling.

The rainhood is painted to match the basic unit and must be field-assembled before installing.

- **MOTORIZED OUTDOOR AIR INTAKE DAMPER** - Includes a slide-in / plug-in damper assembly with a 2-position, spring return motor actuator which opens to some pre-set position whenever the supply air blower is operating and will drive fully closed when the blower unit shuts down.

The rain hood is painted to match the basic unit and must be field assembled before installing.

- **ELECTRIC HEATERS** wired for single point power supply. These nickel chromium heater elements are provided with limit and automatic reset capability to prevent operation at excessive temperatures.
- **ROOF CURBS** - Eight and fourteen-inch high roof curbs provide a water-tight seal between the unit and the finished roof. These full perimeter curbs meet the requirements of the National Roofing Contractors Association (NRCA) and are shipped knocked-down for field assembly.

Roof curbs are designed to fit inside the base rails of the unit and include both a wood nailing strip and duct hanger supports.

- **HIGH ALTITUDE NATURAL GAS** - Burner orifices and pilot orifices are provided for proper furnace operation at altitudes up to 6,000 feet.
- **PROPANE** - Burner orifices, pilot orifices and gas valve parts are provided to convert a natural gas furnace to propane.
- **HIGH ALTITUDE PROPANE** - Burner orifices and pilot orifices are provided for proper furnace operation at alti-

tudes up to 6,000 feet. This accessory supplements the basic propane conversion kit.

- **LOW NOX KIT**- Required to reduce the emission of nitrogen oxides below 40 nanograms per joule.
- **POWER EXHAUST** - Our single input economizer options are available with power exhaust. Whenever the outdoor air intake dampers are opened for free cooling, the exhaust fan will be energized to prevent the conditioned space from being over-pressurized during economizer operation.

The power exhaust option can only be used on bottom duct configurations.

- **BAROMETRIC RELIEF DAMPER** - This damper accessory can be used to relieve internal building air pressure on units with an economizer without power exhaust. This accessory includes a rain hood, a bird screen and a fully assembled damper. With bottom duct connections, the damper should be mounted over the opening in the return air panel. With horizontal ductwork, the accessory should be mounted on the return air duct.
- **ENTHALPY ACCESSORY CONTROL KIT** - This kit contains the required components to convert a single enthalpy economizer to dual enthalpy.
- **BURGLAR BARS** - Mount in the supply and return openings to prevent entry into the duct work.
- **FLUE EXHAUST EXTENSION KIT** - In locations with wind or weather conditions which may interfere with proper exhausting of furnace combustion products, this kit can be installed to prevent the flue exhaust from entering nearby fresh air intakes.
- **CO₂ SENSOR** - Senses CO₂ levels and automatically overrides the economizer when levels rise above the present limits.
- **COIL GUARD** - Customers can purchase a coil guard kit to protect the condenser coil from damage. This is not a hail guard kit.
- **HAIL GUARD** - Hail guard kit is available to prevent unit from hail damage. This is a sloped hood that fits above the coil.
- **GAS PIPING KIT** - This kit supplies all necessary fittings and shut off valve.

TABLE 1: SOUND POWER RATING¹

UNIT SIZE	CFM	ESP	BLOWER		SOUND POWER (db 10 ⁻¹² Watts)									SWL dB(A)	dB(A) @ 10Ft. ²
					Octave Band Centerline Frequency (Hz)										
					IWG	SPEED	KW	63	125	250	500	1,000	2,000		
072	2,200	0.3	HIGH	1.35	87	87	77	70	72	65	60	55	77	44	

1. These values have been accessed using a model of sound propagation from a point source into the hemispheric/free field. The dBA values provided are to be used for reference only. Calculation of dBA values cover matters of system design and the fan manufacture has no way of knowing the details of each system. This constitutes and expectation to any specification or guarantee requiring a dBA value or sound data in any other form than sound power level ratings.
2. At a distance of 10 feet from the blower.

TABLE 2: CAPACITY RATINGS - (ARI 210/240)¹

MODEL	MBH	EER ²
DF072	70.5	10.4

1. 80/67°F Indoor and 95°F outdoor.
2. EER = Energy Efficiency Ratio at full load - the cooling capacity in Btu's per hour (Btuh) divided by the power input in watts, expressed in Btuh per watt (Btuh/watt).

TABLE 3: GAS HEAT RATINGS¹

MODEL	MBH INPUT	MBH OUTPUT	AFUE (%)	TEMP RISE °F
DF072N08	100	80	80.5	25 - 55
DF072N10	125	100	80.3	35 - 65

1. All units are single-stage heating.

TABLE 4: 2 STAGE GAS HEAT RATINGS

MODEL ¹	MBH INPUT		MBH OUTPUT		STEADY STATE EFFICIENCY		RISE		MINIMUM HEATING AIRFLOW (CFM)
	1 ST STAGE	2 ND STAGE	1 ST STAGE	2 ND STAGE	1 ST STAGE	2 ND STAGE	MIN.	MAX.	
DF072D06	45	75	35.8	60.8	79.4	81.1	35	70	1230
DF072D10	75	125	60.4	100.6	80.5	80.5	45	75	1230

1. Models are 3Ø only.

TABLE 5: DF072 COOLING CAPACITIES (6 TON)

Return Air		Temperature of Air on Condenser Coil																			
CFM	WB (°F)	Gross Capacity (MBh)	Power Input (kW) ¹	Gross Sensible Capacity ² (MBh)								Gross Capacity (MBh)	Power Input (kW)	Gross Sensible Capacity (MBh)							
				Return Air Dry Bulb (°F)										Return Air Dry Bulb (°F)							
				86	83	80	77	74	71	68	90			85	80	75	70	65	68		
		85°F								95°F											
2750	72	83.1	5.24	54.6	46.4	38.2	30.0	21.8	-	-	80.2	5.92	53.1	44.9	36.7	28.5	20.3	-	-		
	67	79.5	5.15	67.8	59.6	51.4	43.2	35.0	26.8	18.6	75.3	5.80	66.6	58.4	50.2	42.0	33.8	25.6	17.4		
	62	72.7	5.08	72.7	72.7	64.8	56.6	48.4	40.2	32.0	68.3	5.74	68.3	68.3	62.5	54.3	46.1	37.9	29.7		
	57	66.7	5.04	66.7	66.7	64.6	56.4	48.2	40.0	31.8	65.8	5.77	65.8	65.8	64.5	56.3	48.1	39.9	31.7		
2475	72	82.4	5.25	52.1	44.8	37.5	30.2	22.9	-	-	79.9	5.89	50.5	43.2	35.9	28.6	21.3	-	-		
	67	78.8	5.16	65.0	57.7	50.4	43.1	35.8	28.5	21.2	75.0	5.78	63.8	56.5	49.1	41.8	34.5	27.2	19.9		
	62	72.1	5.10	72.1	70.7	63.5	56.2	48.9	41.6	34.3	68.0	5.72	68.0	67.3	61.2	53.9	46.6	39.3	32.0		
	57	66.1	5.05	66.1	66.1	63.4	56.1	48.8	41.5	34.1	65.5	5.74	65.5	65.5	63.1	55.8	48.5	41.2	33.9		
2200	72	81.7	5.26	49.6	43.2	36.8	30.3	23.9	-	-	79.6	5.87	48.0	41.6	35.2	28.7	22.3	-	-		
	67	78.1	5.18	62.3	55.8	49.4	43.0	36.6	30.2	23.8	74.7	5.75	60.9	54.5	48.1	41.7	35.3	28.9	22.4		
	62	71.4	5.11	71.4	68.7	62.3	55.9	49.5	43.1	36.6	67.7	5.69	67.7	66.3	59.9	53.5	47.1	40.7	34.3		
	57	65.5	5.06	65.5	65.5	62.1	55.7	49.3	42.9	36.5	65.2	5.72	65.2	65.2	61.8	55.4	49.0	42.6	36.2		
1925	72	79.3	5.24	45.6	40.0	34.5	28.9	23.4	-	-	77.1	5.86	43.9	38.4	32.8	27.2	21.7	-	-		
	67	75.8	5.15	57.5	51.9	46.4	40.8	35.3	29.7	24.1	72.3	5.74	56.0	50.4	44.9	39.3	33.8	28.2	22.6		
	62	69.4	5.08	67.7	64.0	58.5	52.9	47.3	41.8	36.2	65.6	5.68	64.5	61.5	55.9	50.3	44.8	39.2	33.7		
	57	63.6	5.04	63.6	62.3	58.3	52.7	47.2	41.6	36.1	63.2	5.71	63.2	61.7	57.7	52.1	46.5	41.0	35.4		
1650	72	77	5.21	41.6	36.9	32.2	27.5	22.8	-	-	74.5	5.85	39.8	35.1	30.4	25.7	21.0	-	-		
	67	73.6	5.12	52.7	48.0	43.3	38.6	33.9	29.2	24.5	69.9	5.73	51.0	46.3	41.6	36.9	32.2	27.5	22.8		
	62	67.3	5.06	64.0	59.3	54.6	49.9	45.2	40.5	35.8	63.4	5.67	61.3	56.6	51.9	47.2	42.5	37.7	33.0		
	57	61.7	5.01	61.7	59.2	54.5	49.8	45.0	40.3	35.6	61.1	5.70	61.1	58.2	53.5	48.8	44.1	39.4	34.7		
		105°F								115°F											
2750	72	76.3	6.66	51.5	43.3	35.1	26.9	18.7	-	-	72.4	7.40	50.0	41.8	33.6	25.4	17.2	-	-		
	67	70.2	6.55	64.2	56.0	47.8	39.6	31.5	23.3	15.1	65.0	7.31	61.9	53.7	45.5	37.3	29.1	20.9	12.7		
	62	62.2	6.48	62.2	62.2	58.8	50.6	42.4	34.2	26.0	56.1	7.22	56.1	56.1	55.2	47.0	38.8	30.6	22.4		
	57	61.2	6.50	61.2	61.2	60.1	51.9	43.7	35.5	27.3	56.7	7.24	56.7	56.7	55.7	47.5	39.3	31.1	22.9		
2475	72	76.1	6.63	49.0	41.7	34.3	27.0	19.7	-	-	72.3	7.36	47.4	40.1	32.8	25.5	18.2	-	-		
	67	70.0	6.52	61.4	54.1	46.8	39.5	32.2	24.9	17.6	65.0	7.26	59.1	51.7	44.4	37.1	29.8	22.5	15.2		
	62	62.0	6.45	62.0	61.7	57.5	50.2	42.9	35.6	28.3	56.1	7.18	56.1	56.1	53.9	46.6	39.2	31.9	24.6		
	57	61.0	6.47	61.0	61.0	58.8	51.5	44.2	36.9	29.5	56.6	7.19	56.6	56.6	54.4	47.1	39.8	32.5	25.2		
2200	72	75.9	6.59	46.4	40.0	33.6	27.2	20.7	-	-	72.2	7.31	44.8	38.4	32.0	25.6	19.2	-	-		
	67	69.8	6.48	58.6	52.2	45.7	39.3	32.9	26.5	20.1	64.9	7.22	56.2	49.8	43.4	37.0	30.5	24.1	17.7		
	62	61.9	6.41	61.9	61.2	56.2	49.8	43.4	37.0	30.6	56.0	7.13	56.0	56.0	52.6	46.2	39.7	33.3	26.9		
	57	60.9	6.43	60.9	60.9	57.5	51.0	44.6	38.2	31.8	56.5	7.15	56.5	56.5	53.1	46.7	40.3	33.9	27.4		
1925	72	73.1	6.58	42.3	36.7	31.1	25.6	20.0	-	-	69.1	7.30	40.6	35.0	29.5	23.9	18.4	-	-		
	67	67.2	6.47	53.5	48.0	42.4	36.9	31.3	25.7	20.2	62.1	7.20	51.1	45.5	40.0	34.4	28.8	23.3	17.7		
	62	59.6	6.40	59.1	57.0	52.2	46.6	41.0	35.5	29.9	53.6	7.12	53.6	52.5	48.4	42.9	37.3	31.7	26.2		
	57	58.6	6.42	58.6	57.3	53.3	47.7	42.2	36.6	31.0	54.1	7.13	54.1	53.0	48.9	43.3	37.8	32.2	26.7		
1650	72	70.3	6.57	38.1	33.4	28.7	24.0	19.3	-	-	66.1	7.28	36.4	31.7	26.9	22.2	17.5	-	-		
	67	64.6	6.46	48.5	43.8	39.1	34.4	29.7	25.0	20.3	59.4	7.19	45.9	41.2	36.5	31.8	27.1	22.4	17.7		
	62	57.3	6.39	56.3	52.8	48.1	43.4	38.7	34.0	29.2	51.2	7.11	51.2	49.0	44.3	39.6	34.9	30.2	25.5		
	57	56.4	6.41	56.4	53.8	49.1	44.4	39.7	35.0	30.3	51.7	7.12	51.7	49.4	44.7	40.0	35.3	30.6	25.9		

1. These ratings include the compressor and the condenser fan motors but not the supply air blower motor. The total condenser fan motor power input is 0.36kW. Refer to the SUPPLY AIR BLOWER PERFORMANCE Table for the kW of the supply air blower motor.
2. These capacities are gross ratings. For net capacity, determine the kW of the supply air blower motor from the SUPPLY AIR BLOWER PERFORMANCE Table, multiply this value by 3.425 MBH/kW to determine the motor heat, and deduct this heat from the gross capacity of the unit.

Nominal Rating

TABLE 6: SUPPLY AIR BLOWER PERFORMANCE (6 TON BELT DRIVE) - SIDE DUCT APPLICATION

Unit Tonnage	Air Flow (CFM)	Available External Static Pressure - IWG ¹													
		0.2		0.3		0.4		0.5		0.6		0.7		0.8	
		RPM	Watts	RPM	Watts	RPM	Watts	RPM	Watts	RPM	Watts	RPM	Watts	RPM	Watts
6 ^{2,3}	2500	1059	1560	1077	1590	1095	1630	1114	1650	1134	1660	1158	1685	1181	1720
	2400	1032	1405	1054	1470	1074	1525	1094	1560	1116	1595	1140	1620	1167	1640
	2300	1005	1260	1024	1275	1049	1370	1069	1440	1090	1475	1116	1505	1142	1535
	2200	980	1160	1002	1170	1022	1190	1044	1250	1066	1350	1090	1410	1117	1440
	2100	930	1060	957	1070	983	1080	1010	1100	1039	1160	1064	1260	1092	1340
	2000	877	950	908	975	941	1000	976	1020	1009	1050	1040	1100	1070	1225
	1900	-	-	-	-	894	885	940	940	980	980	1014	1020	1047	1095
	1800	-	-	-	-	855	815	903	860	950	905	988	940	1022	970
	1700	-	-	-	-	-	-	884	815	925	850	964	880	1001	910
	1600	-	-	-	-	-	-	864	770	908	805	948	835	987	870
	1500	-	-	-	-	-	-	-	-	882	740	926	780	965	830

Unit Tonnage	Air Flow (CFM)	Available External Static Pressure - IWG ¹													
		0.9		1.0		1.1		1.2		1.3		1.4		1.5	
		RPM	Watts	RPM	Watts	RPM	Watts	RPM	Watts	RPM	Watts	RPM	Watts	RPM	Watts
6 ^{2,3}	2500	-	-	-	-	-	-	-	-	-	-	-	-	-	-
	2400	1193	1665	-	-	-	-	-	-	-	-	-	-	-	-
	2300	1170	1580	1202	1620	-	-	-	-	-	-	-	-	-	-
	2200	1148	1480	1180	1530	-	-	-	-	-	-	-	-	-	-
	2100	1121	1385	1155	1425	1190	1475	-	-	-	-	-	-	-	-
	2000	1100	1285	1133	1340	1169	1385	1205	1445	-	-	-	-	-	-
	1900	1079	1180	1110	1240	1143	1280	1178	1330	1222	1375	-	-	-	-
	1800	1058	1060	1090	1135	1122	1190	1158	1240	1196	1295	-	-	-	-
	1700	1035	960	1071	1030	1103	1100	1134	1140	1164	1175	1197	1205	-	-
	1600	1020	900	1056	965	1088	1035	1118	1065	1145	1105	1170	1130	1198	1150
	1500	1004	860	1038	880	1070	925	1101	980	1130	1045	1158	1075	1184	1110

1. Includes allowances for a wet evaporator coil, 1" filters, and the heat exchangers. Refer to STATIC RESISTANCE Table for resistance values on applications other than gas / electric units with side duct airflows.
2. 230/460/575 Volts
3. For 208 Volts multiply values by 0.95.

TABLE 7: BELT DRIVE BLOWER MOTOR AND DRIVE DATA

MODEL SIZE	BLOWER RANGE (RPM)	MOTOR ¹		ADJUSTABLE MOTOR PULLEY				FIXED BLOWER PULLEY				BELT (NOTCHED)		
		HP	FRAME	DESIG-NATION	OUTSIDE DIA. (IN.)	PITCH DIA. (IN.)	BORE (IN.)	DESIG-NATION	OUTSIDE DIA. (IN.)	PITCH DIA. (IN.)	BORE (IN.)	DESIG-NATION	PITCH LENGTH (IN.)	QTY.
6 TON	850/1220	1 1/2	56	1VL40	2.7-3.7	2.4-3.4	5/8	AK56	5.4	5.2	1	A36	37.3	1

1. All motors have solid bases and are inherently protected. these motors can be selected to operate into their service factor because they are located in the moving air, upstream of any heating device.

TABLE 8: SUPPLY AIR BLOWER PERFORMANCE (6 TON BELT DRIVE) - SIDE DUCT APPLICATION

Unit Tonnage	Motor Speed	Available External Static Pressure - IWG ¹									
		0.2		0.3		0.4		0.5		0.6	
		CFM	Watts	CFM	Watts	CFM	Watts	CFM	Watts	CFM	Watts
6 ²	Hi	2256	883	2258	931	2247	950	2223	964	2182	979
	Med/Hi	2145	771	2127	784	2119	808	2089	826	2051	844
	Med	2020	637	1999	656	1985	675	1947	696	1910	715
	Med/Low	-	-	-	-	-	-	-	-	-	-
	Low	-	-	-	-	-	-	-	-	-	-

Unit Tonnage	Motor Speed	Available External Static Pressure - IWG ¹							
		0.7		0.8		0.9		1.0	
		CFM	Watts	CFM	Watts	CFM	Watts	CFM	Watts
6 ²	Hi	2125	971	2044	940	1958	898	1864	854
	Med/Hi	2014	859	1965	861	1896	843	1801	806
	Med	1876	730	1832	740	1793	756	-	-
	Med/Low	-	-	-	-	-	-	-	-
	Low	-	-	-	-	-	-	-	-

1. Includes allowances for a wet evaporator coil, 1" filters, and the heat exchangers. Refer to STATIC RESISTANCES Table for resistance values.
2. Side Duct application (230 Volts)

TABLE 9: STATIC RESISTANCES

DESCRIPTION	RESISTANCE, IWG											
	CFM											
	1000	1200	1400	1600	1800	2000	2200	2400	2600	2800	3000	
ECONOMIZER ^{1,3}	0.07	0.08	0.09	0.11	0.13	0.15	0.17	0.20	0.23	0.26	0.30	
ELECTRIC HEATERS ¹	7-15KW	0.04	0.05	0.06	0.07	0.08	0.10	0.12	0.14	0.16	0.19	0.22
	20-30KW	0.06	0.07	0.08	0.09	0.11	0.13	0.15	0.17	0.20	0.23	0.26
BOTTOM DUCT CONNECTIONS ¹	0.06	0.07	0.08	0.09	0.10	0.11	0.12	0.14	0.16	0.19	0.22	
COOLING ONLY ²	0.08	0.10	0.12	0.14	0.16	0.18	0.20	0.23	0.26	0.29	0.32	

1. Deduct these resistance values from the available external static pressure shown in SUPPLY AIR BLOWER PERFORMANCE Tables.
2. Add these resistance values to the available static resistance values on SUPPLY AIR BLOWER PERFORMANCE Tables.
3. The pressure through the economizer is greater for 100% outdoor air than for 100% return air. If the resistance of the return air duct system is less than 0.25 IWG, the unit will deliver less CFM during full economizer operation.

TABLE 10: ELECTRIC HEATER CFM LIMITATIONS

UNIT MODEL SIZE NOMI-NAL TONS	VOLTAGE	MINIMUM SUPPLY AIR CFM					
		HEATER SIZE NOMINAL KW					
		5	7	10	15	20	30
6	208/230-3-60	1800	1800	1800	1800	1800	1800
	460-3-60	-	1800	1800	1800	1800	1800
	575-3-60	-	-	1800	1800	1800	1800

TABLE 11: ELECTRICAL DATA - DF072 BELT DRIVE W/O POWERED CONV. OUTLET

MODEL TONNAGE	VOLTAGE	COMPRESSORS		OD FAN MOTOR FLA	ID BLOWER MOTOR FLA	CONV OUTLET FLA	ELECTRIC HEATER MODEL NO.	HEATER KW	HEATER AMPS	MIN. CIRCUIT AMPACITY (AMPS)	MAX. FUSE/ BRKR ¹ SIZE (AMPS)
		RLA EACH	LRA EACH								
DF072 (6.0)	208-3-60	20.7	156.0	2.3	5.2	0.0	None	-	-	33.4	45
							2CE04510525 ²	4	11.1	33.4	45
							2CE04510725 ²	5.6	15.5	33.4	45
							2CE04511025	8	22.2	34.3	45
							2CE04511525	11.9	33.0	47.8	50
							2CE04512025	15.9	44.1	61.7	70
							2CE04513025	22.2	61.6	83.5	90
	230-3-60	20.7	156.0	2.3	5.2	0.0	None	-	-	33.4	45
							2CE04510525 ²	5.3	12.7	33.4	45
							2CE04510725 ²	7.5	18.0	33.4	45
							2CE04511025	10.6	25.5	38.4	50
							2CE04511525	15.9	38.2	54.3	60
							2CE04512025	21.2	51.0	70.2	80
							2CE04513025	29.6	71.2	95.5	100
	460-3-60	10.0	75.0	1.3	2.6	0.0	None	-	-	16.4	25
							2CE04510746 ²	6.8	8.2	16.4	25
							2CE04511046 ²	10.1	12.1	18.4	25
							2CE04511546 ²	13.6	16.4	23.7	25
							2CE04512046 ²	19.5	23.5	32.6	35
							2CE04513046 ²	28.8	34.6	46.6	50
							None	-	-	13.3	20
	575-3-60	8.2	54.0	1.3	2.0	0.0	2CE04511058	10.6	10.2	15.2	20
							2CE04511558	15.9	15.3	21.6	25
							2CE04512058	21.2	20.4	28	30
							2CE04513058	30.4	29.3	39.1	40
							None	-	-	13.3	20

1. HACR Type per NEC.

2. These electric heaters do not include a fuse box. If a fuse box is required to meet a local code (i.e. Chicago), the fuse block accessories 2FB04700825 and 2FB04700846 are available for field installation.

TABLE 12: ELECTRICAL DATA - DF072 DIRECT DRIVE W/O POWERED CONV. OUTLET

MODEL TONNAGE	VOLTAGE	COMPRESSORS		OD FAN MOTOR FLA	ID BLOWER MOTOR FLA	CONV OUTLET FLA	ELECTRIC HEATER MODEL NO.	HEATER KW	HEATER AMPS	MIN. CIRCUIT AMPACITY (AMPS)	MAX. FUSE/ BRKR ¹ SIZE (AMPS)
		RLA EACH	LRA EACH								
DF072 (6.0)	208-3-60	20.7	156.0	2.3	10.6	0.0	None	-	-	38.8	50
							2CE04510525 ²	4.0	11.1	38.8	50
							2CE04510725 ²	5.6	15.5	38.8	50
							2CE04511025	8.0	22.2	41.0	50
							2CE04511525	11.9	33.0	54.5	60
							2CE04512025	15.9	44.1	68.4	70
							2CE04513025	22.2	61.6	90.3	100
	230-3-60	20.7	156.0	2.3	10.6	0.0	None	-	-	38.8	50
							2CE04510525 ²	5.3	12.7	38.8	50
							2CE04510725 ²	7.5	18.0	38.8	50
							2CE04511025	10.6	25.5	45.1	50
							2CE04511525	15.9	38.2	61.1	70
							2CE04512025	21.2	51.0	77.0	80
							2CE04513025	29.6	71.2	102.3	110
							None	-	-	13.3	20
							None	-	-	13.3	20
							None	-	-	13.3	20

1. HACR Type per NEC.

2. These electric heaters do not include a fuse box. If a fuse box is required to meet a local code (i.e. Chicago), the fuse block accessories 2FB04700825 and 2FB04700846 are available for field installation.

TABLE 13: ELECTRICAL DATA - DF072 BELT DRIVE W/POWERED CONV. OUTLET

MODEL TONNAGE	VOLTAGE	COMPRESSORS		OD FAN MOTOR FLA	ID BLOWER MOTOR FLA	CONV OUTLET FLA	ELECTRIC HEATER MODEL NO.	HEATER KW	HEATER AMPS	MIN. CIRCUIT AMPACITY (AMPS)	MAX. FUSE/ BRKR ¹ SIZE (AMPS)
		RLA EACH	LRA EACH								
DF072 (6.0)	208-3-60	20.7	156.0	2.3	5.2	10.0	None	-	-	43.4	60
							2CE04510525 ²	4	11.1	43.4	60
							2CE04510725 ²	5.6	15.5	43.4	60
							2CE04511025	8	22.2	46.8	60
							2CE04511525	11.9	33.0	60.3	70
							2CE04512025	15.9	44.1	74.2	80
	2CE04513025	22.2	61.6	96	100						
	230-3-60	20.7	156.0	2.3	5.2	10.0	None	-	-	43.4	60
							2CE04510525 ²	5.3	12.7	43.4	60
							2CE04510725 ²	7.5	18.0	43.4	60
							2CE04511025	10.6	25.5	50.9	60
							2CE04511525	15.9	38.2	66.8	70
							2CE04512025	21.2	51.0	82.7	90
	2CE04513025	29.6	71.2	108	110						
	460-3-60	10.0	75.0	1.3	2.6	5.0	None	-	-	21.4	30
							2CE04510746 ²	6.8	8.2	21.4	30
							2CE04511046 ²	10.1	12.1	24.7	30
							2CE04511546 ²	13.6	16.4	29.9	30
							2CE04512046 ²	19.5	23.5	38.8	40
							2CE04513046 ²	28.8	34.6	52.8	60
575-3-60	8.2	54.0	1.3	2.0	4.0	None	-	-	17.3	25	
						2CE04511058	10.6	10.2	20.2	25	
						2CE04511558	15.9	15.3	26.6	30	
						2CE04512058	21.2	20.4	33	35	
						2CE04513058	30.4	29.3	44.1	45	

1. HACR Type per NEC.
2. These electric heaters do not include a fuse box. If a fuse box is required to meet a local code (i.e. Chicago), the fuse block accessories 2FB04700825 and 2FB04700846 are available for field installation.

TABLE 14: ELECTRICAL DATA - DF072 DIRECT DRIVE W/POWERED CONV. OUTLET

MODEL TONNAGE	VOLTAGE	COMPRESSORS		OD FAN MOTOR FLA	ID BLOWER MOTOR FLA	CONV OUTLET FLA	ELECTRIC HEATER MODEL NO.	HEATER KW	HEATER AMPS	MIN. CIRCUIT AMPACITY (AMPS)	MAX. FUSE/ BRKR ¹ SIZE (AMPS)
		RLA EACH	LRA EACH								
DF072 (6.0)	208-3-60	20.7	156.0	2.3	10.6	10.0	None	-	-	48.8	60
							2CE04510525 ²	4.0	11.1	48.8	60
							2CE04510725 ²	5.6	15.5	48.8	60
							2CE04511025	8.0	22.2	53.5	60
							2CE04511525	11.9	33.0	67.0	70
							2CE04512025	15.9	44.1	80.9	90
	2CE04513025	22.2	61.6	102.8	110						
	230-3-60	20.7	156.0	2.3	10.6	10.0	None	-	-	48.8	60
							2CE04510525 ²	5.3	12.7	48.8	60
							2CE04510725 ²	7.5	18.0	48.8	60
							2CE04511025	10.6	25.5	57.6	60
							2CE04511525	15.9	38.2	73.6	80
							2CE04512025	21.2	51.0	89.5	90
							2CE04513025	29.6	71.2	114.8	125

1. HACR Type per NEC.
2. These electric heaters do not include a fuse box. If a fuse box is required to meet a local code (i.e. Chicago), the fuse block accessories 2FB04700825 and 2FB04700846 are available for field installation.

TABLE 15: DF PHYSICAL DATA

MODELS		DF
		072
EVAPORATOR BLOWER	Centrifugal Blower (Dia. x Wd. in.)	12 X 10
	Fan Motor HP (Direct Drive)	1
	Fan Motor HP (Belt Drive)	1 1/2
EVAPORATOR COIL	Rows Deep	4
	Fins Per Inch	13
	Face Area (Sq. Ft.)	5.1
CONDENSER FANS	Propeller Dia. (in.)	24
	Fan Motor Hp	1/2
	Nom. CFM	4200
CONDENSER COILS	Rows Deep	2
	Fins Per Inch	18
	Face Area (Sq. Ft.)	17.1
COMPRESSOR (Qty. Per Unit)	Recip Type	1
AIR FILTERS	Quantity Per Unit (15" X 20" X 1" or 2")	2
	Quantity Per Unit (14" X 25" X 1" or 2")	1
	Total Face Area (sq. ft.)	6.3
CHARGE	Refrigerant 22 (lbs./oz.)	11/10

TABLE 16: ELECTRIC HEAT CORRECTION FACTORS

NOMINAL VOLTAGE	VOLTAGE	KW CAP. MULTIPLIER
208	208	0.75
240	230	0.92
480	460	0.92
600	575	0.92

TABLE 17: VOLTAGE LIMITATIONS¹

POWER SUPPLY	VOLTAGE	
	MIN.	MAX.
208/230-3-60	187	252
460-3-60	432	504
575-3-60	540	630

1. Utilization Range "A" in accordance with ARI Standard 110.

TYPICAL POWER WIRING

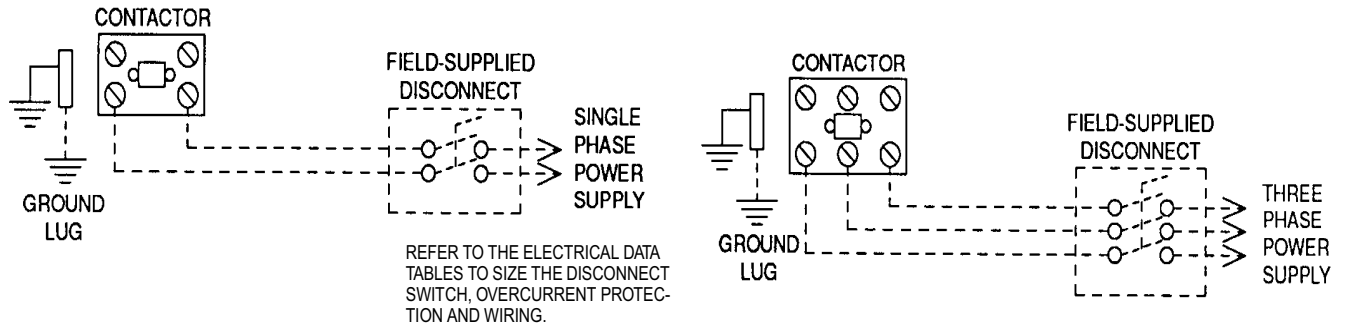

TYPICAL CONTROL WIRING

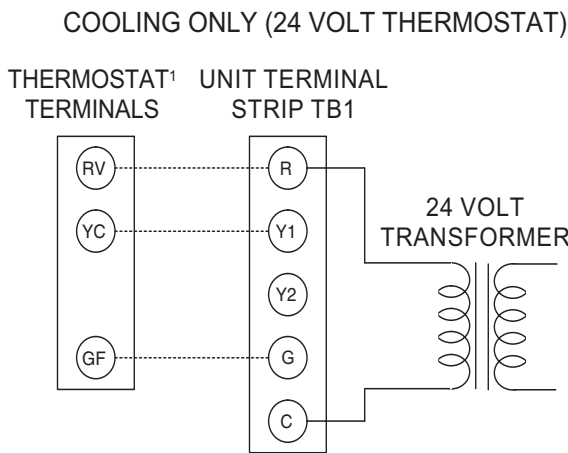

¹24 VOLT THERMOSTAT 2TH07701024. TO CONTROL THE ECONOMIZER ON SECOND STAGE COOLING, USE THE THERMOSTAT 2TH0401224.

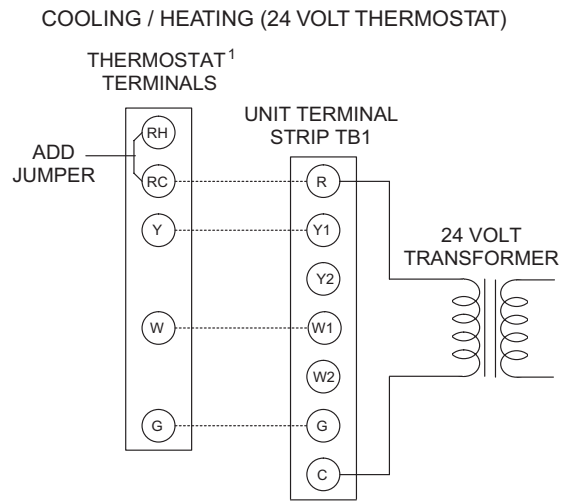

¹24 VOLT THERMOSTAT 2ET07701024. TO CONTROL THE ECONOMIZER ON THE SECOND STAGE COOLING OR TO HAVE AN ELECTRIC HEAT ACCESSORY WITH TWO STAGES OF HEAT, USE THERMOSTAT 2TH0471024.

COOLING / HEATING (ELECTRONIC THERMOSTAT) MULTI STAGE

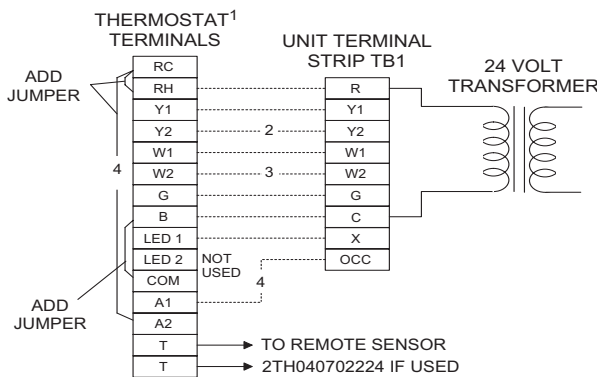

¹ ELECTRONIC PROGRAMMABLE THERMOSTAT 2ET04700224 (INCLUDES SUBBASE).
² SECOND STAGE COOLING IS NOT REQUIRED ON UNITS LESS ECONOMIZER.
³ SECOND STAGE HEATING IS ONLY REQUIRED ON UNITS WITH A TWO STAGE ELECTRIC HEATER OR 2 STAGE GAS HEAT.
⁴ REMOVE JUMPER J2 FROM TERMINALS 4 AND 9 ON JUMPER PLUG CONNECTOR P6 ON UNITS WITH ECONOMIZER. TERMINALS A1 AND A2 PROVIDE A RELAY OUTPUT TO CLOSE THE OUTDOOR ECONOMIZER DAMPERS WHEN THE THERMOSTAT SWITCHES TO THE SET-BACK POSITION.

COOLING / HEATING (ELECTRONIC THERMOSTAT) SINGLE STAGE

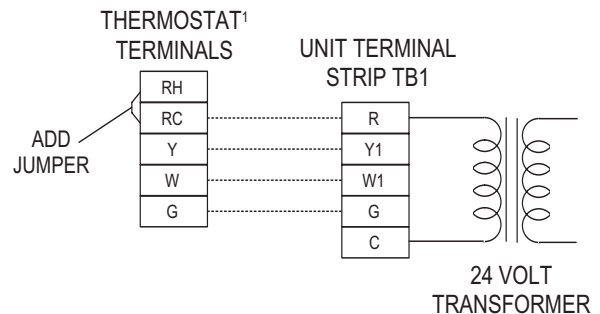

¹ELECTRONIC PROGRAMMABLE THERMOSTAT 2ET07701024 (INCLUDES SUBBASE). TO CONTROL THE ECONOMIZER ON SECOND STAGE COOLING, USE THERMOSTAT 2TH04700224.

FIGURE 2 - TYPICAL FIELD POWER & CONTROL WIRING

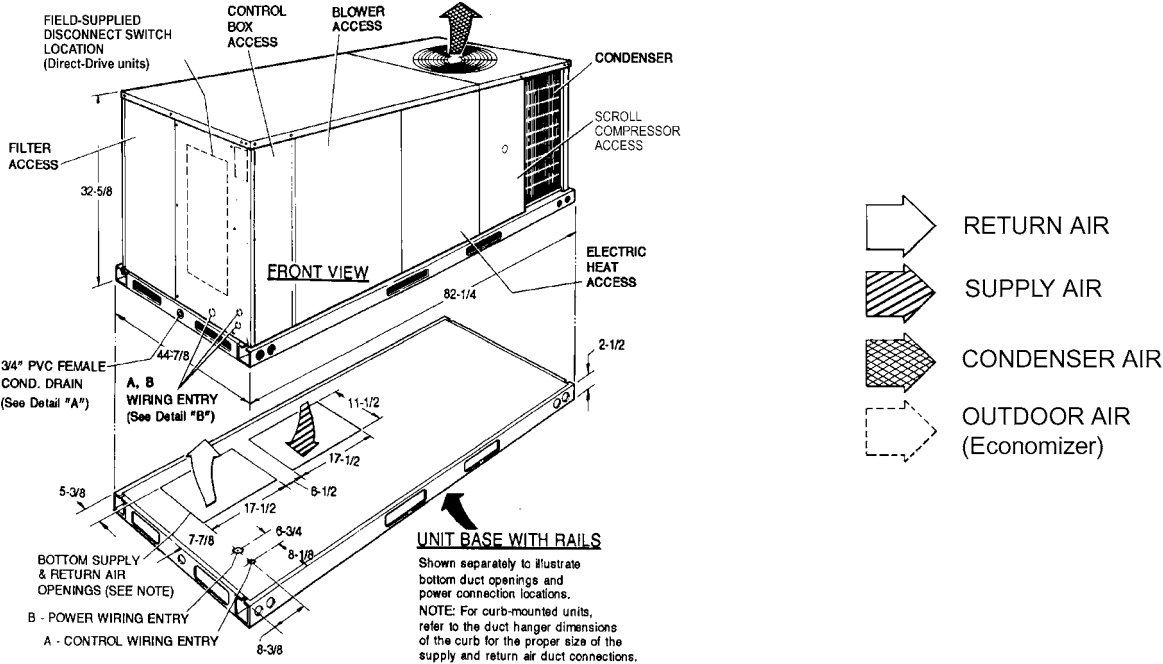

FIGURE 3 - UNIT DIMENSIONS (6 TON COOLING ONLY/ELECTRIC HEAT) FRONT VIEW

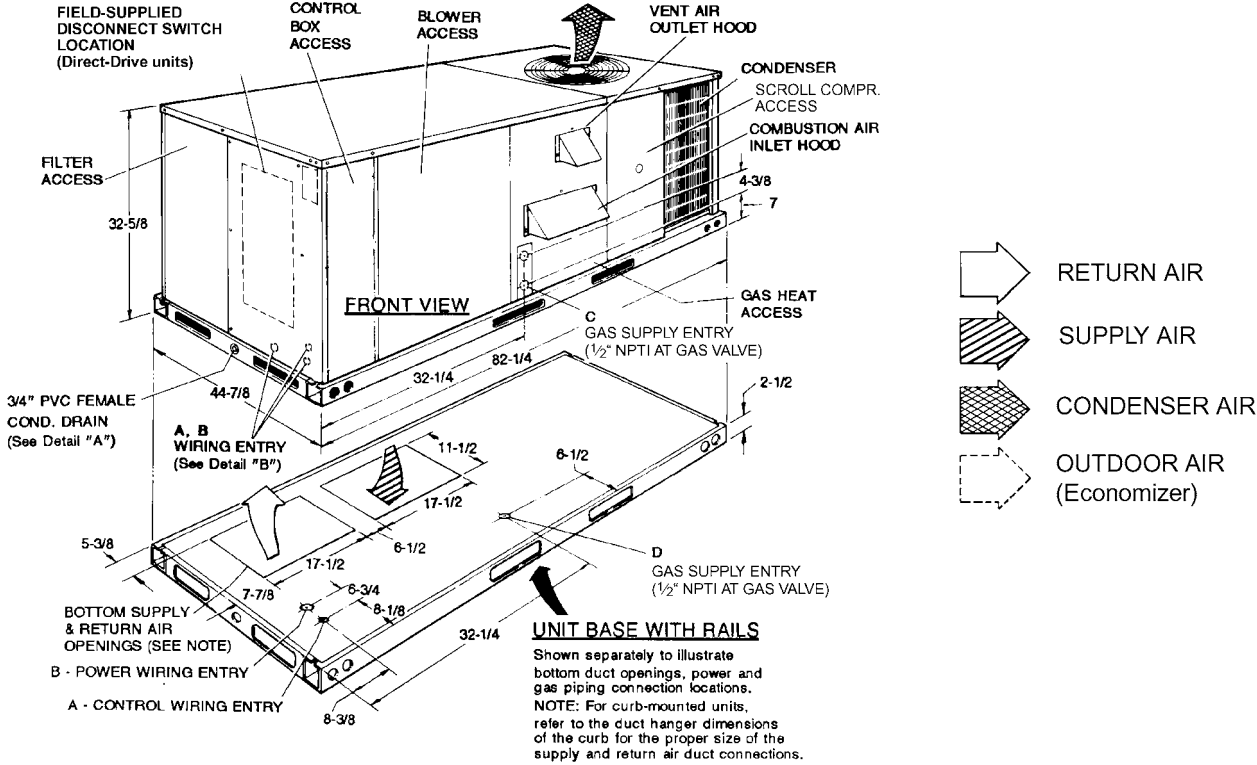

FIGURE 4 - UNIT DIMENSIONS (6 TON COOLING/GAS HEAT) FRONT VIEW

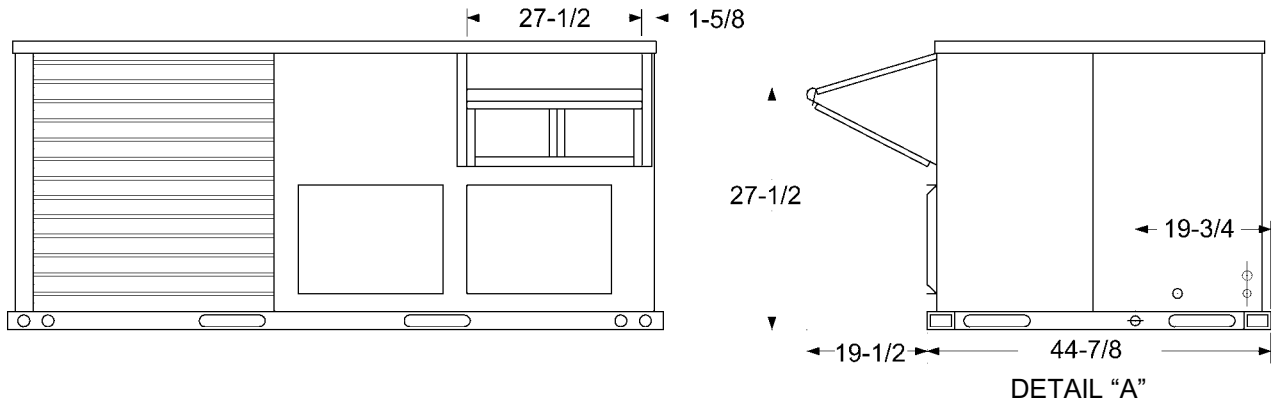

FIGURE 5 - UNIT WITH ECONOMIZER RAINHOOD

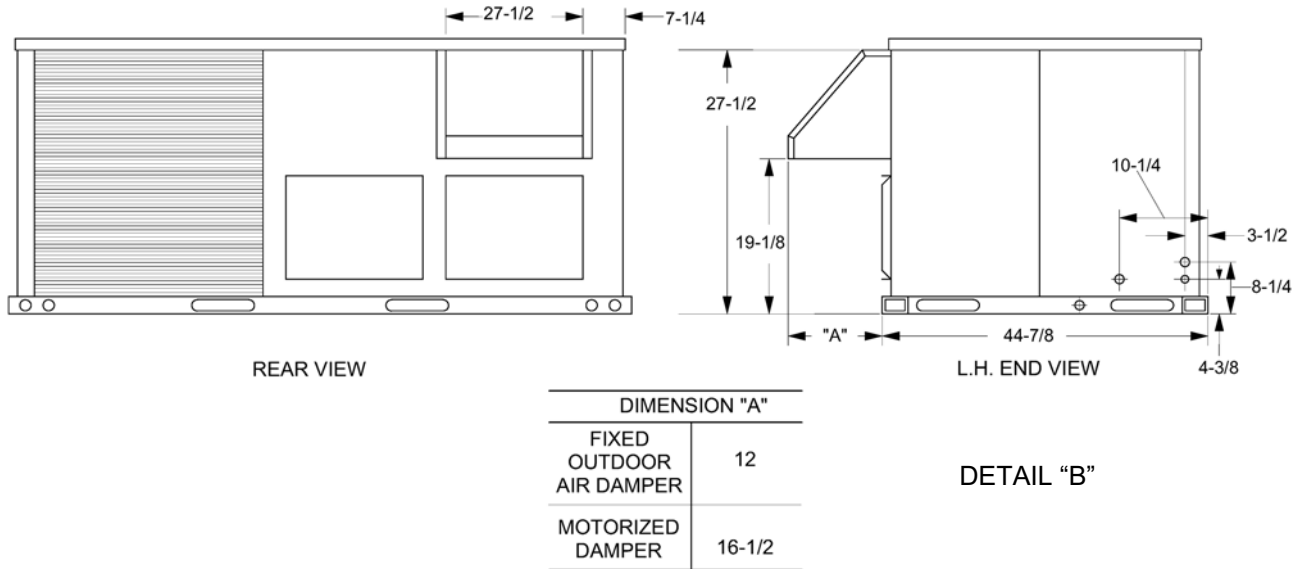

FIGURE 6 - UNIT WITH FIXED OUTDOOR AIR/MOTORIZED DAMPER RAINHOOD

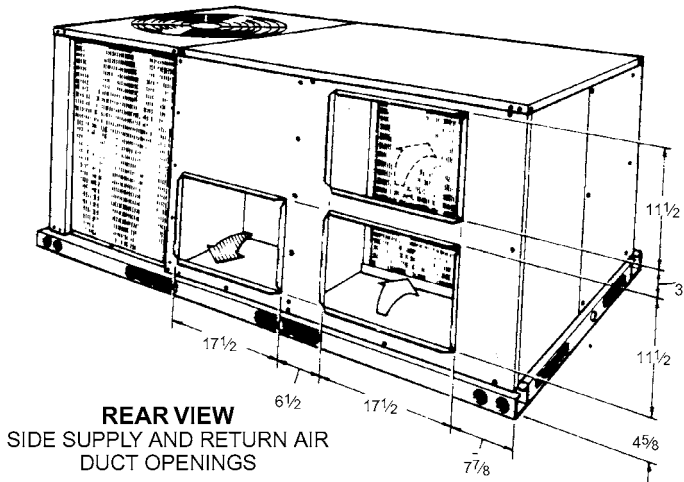

FIGURE 7 - UNIT DIMENSIONS (REAR VIEW)

DUCT COVERS - Units are shipped with all air duct openings covered.

For side duct applications;

1. Remove and discard the supply and return air duct covers.
2. Connect ductwork to duct flanges on the rear of the unit.

For bottom duct applications;

1. Remove the side supply air duct cover to gain access to the bottom supply air knockout panel.
2. Remove and discard the bottom knockout panel.
3. Replace the side duct cover.
4. With filter section access panel removed from the unit, remove and discard the bottom return air knockout panel.
5. Replace the filter access panel.

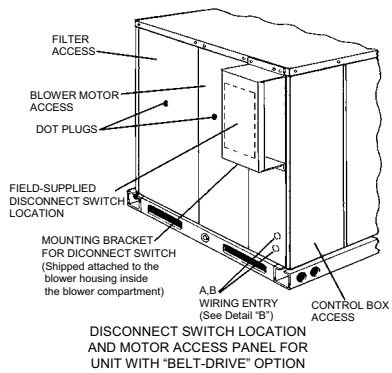

FIGURE 8 - DISCONNECT/BLOWER ACCESS LOCATION

TABLE 18: UTILITIES ENTRY

HOLE	OPENING SIZE (DIA.)	USED FOR	
A	7/8" KO ¹	Control Wiring ²	Side
			Bottom
B	2" KO ¹	Power Wiring	Side
			Bottom
C	1-5/8" KO	Gas Piping (Front)	
D	1-1/2" KO	Gas Piping (Bottom)	

1. Opening in the bottom to the unit can be located by the side in the insulation.
2. Do not remove the 2" knockout ring.

TABLE 19: MINIMUM CLEARANCES

LOCATION	CLEARANCE
Front	24" (Cooling/Electric Heat)
	32" (Gas Heat)
Rear	12" (Less Economizer)
	36" (With Economizer or Fixed Air/Motorized Damper)
Left Side (Filter Access)	24" (Less Economizer)
	36" (With Economizer)
Right Side (Cond. Coil)	24"
Below Unit ¹	0"
Above Unit ²	72" (For Condenser Air Discharge)

1. Units may be installed on combustible floors made from wood or class A, B, or C roof covering material.
2. Units must be installed outdoors. Overhanging structures or shrubs should not obstruct condenser air discharge outlet.

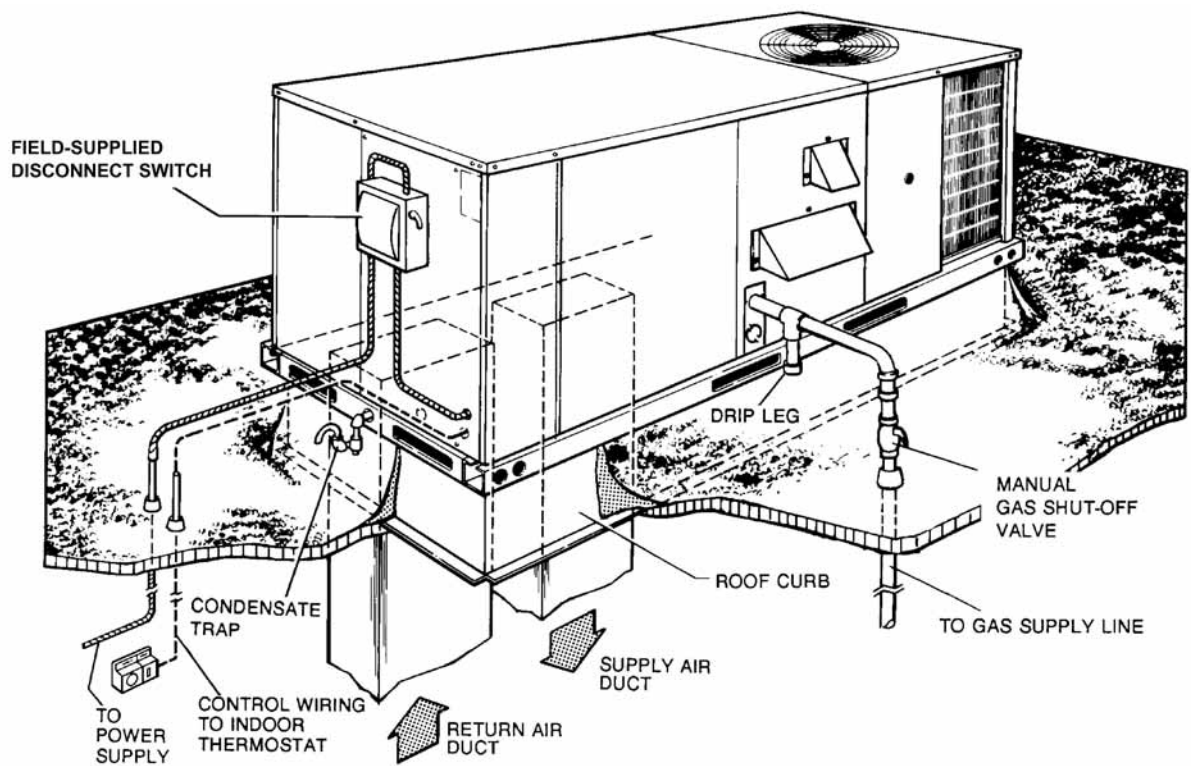
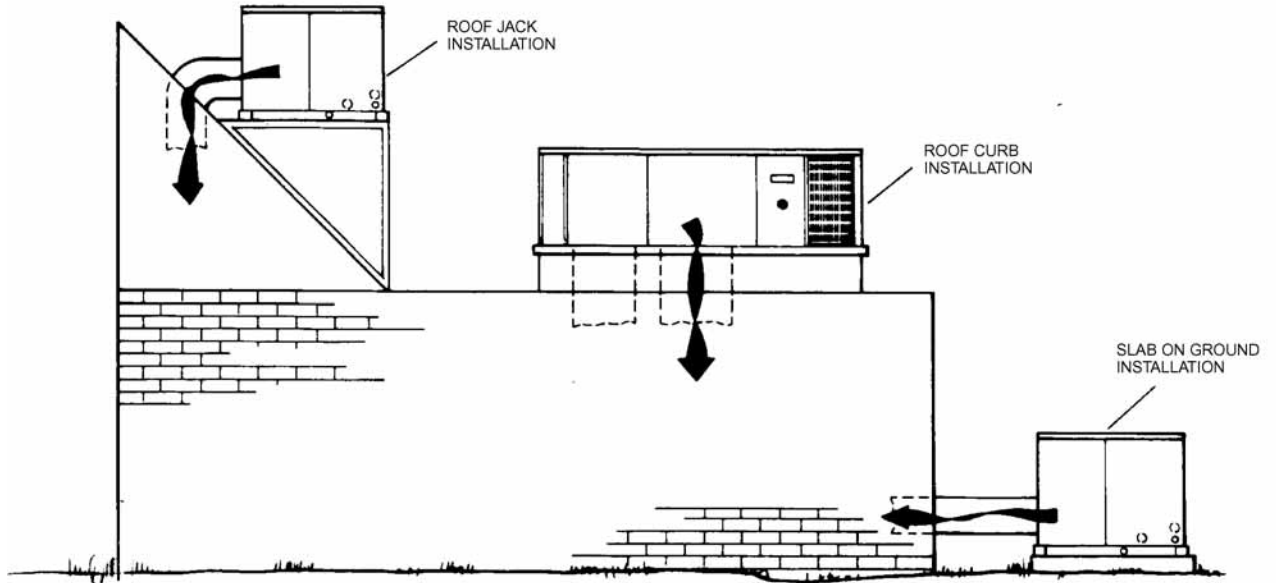

FIGURE 9 - TYPICAL APPLICATIONS

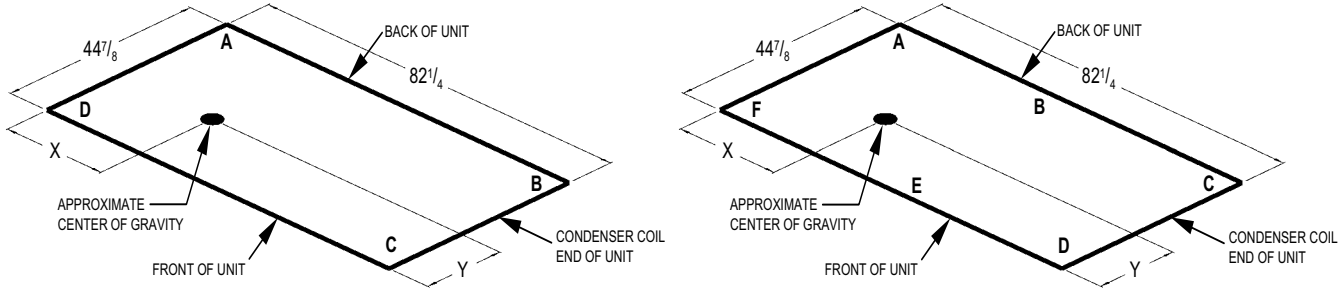

FIGURE 10 - FOUR AND SIX POINT LOADING

TABLE 20: DF 4 AND 6 POINT LOADS WEIGHT DISTRIBUTION

UNIT	TOTAL	4-Point Loading (lb)				6-Point Loading (lb)					
		A	B	C	D	A	B	C	D	E	F
DF072 Cooling/ Electric	660	147	144	183	186	98	97	96	122	123	125
DF072D06	710	158	155	197	201	105	104	103	131	132	134
DF072N08	720	160	157	200	203	107	106	104	133	134	136
DF072(D,N)10	730	162	159	202	206	108	107	106	135	136	138

TABLE 21: CENTER OF GRAVITY

DIMENSION	3 - 5 TON	6 TON
X	40-3/4"	44"
Y	19-3/4"	22"

TABLE 22: DF OPERATING WEIGHTS (LBS.)

MODEL SIZE		6 TON	
BASIC UNIT	DF (Cooling Only)	660	
	DF (Gas/Electric)	N04	-
		N06	-
		N08	720
		N10	730
		D06	760
D10	730		
OPTIONS	Economizer	50	
	Motorized Damper	26	
	Electric Heater	5 - 7 kW	18
		10 - 15 kW	23
20 - 30 kW		28	
ACCY.	Roof Curb	92	
	Barometric Relief / Fixed Air Damper	10	
	Belt-Drive Blower	5	

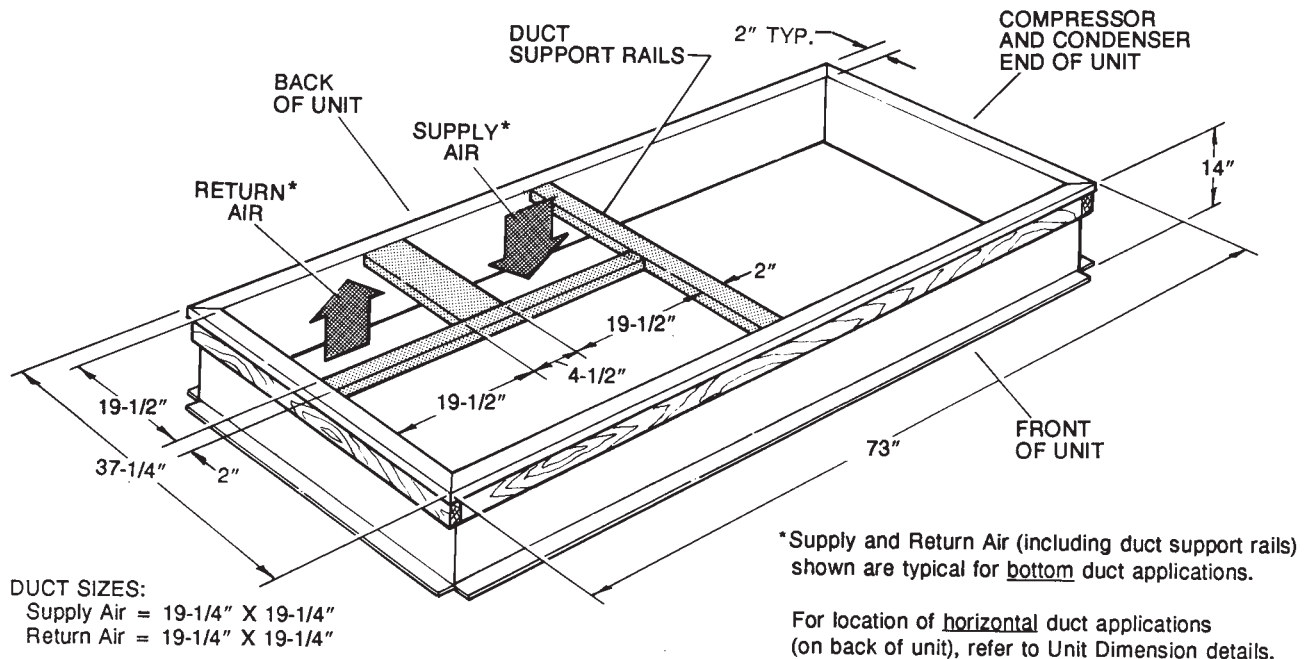

FIGURE 11 - ROOF CURB DIMENSIONS

GUIDE SPECIFICATIONS

GENERAL

Units shall be manufactured by York International Unitary Products Group in an ISO 9001 certified facility.

York's Sunline Plus™ units are convertible single package units. Although the units are primarily designed for curb mounting on a roof, they can also be slab-mounted at ground level or set on steel beams above a finished roof. Cooling only, cooling with gas heat and cooling with electric heat models are available with a wide variety of factory-mounted options and field-installed accessories to make them suitable for almost every application. All units are self-contained and assembled on full perimeter base rails with holes in the four corners for overhead rigging. Every unit is completely piped, wired, charged and tested at the factory to simplify the field installation and to provide years of dependable operation. All models (including those with an economizer) are suitable for either bottom or horizontal duct connections. Models with power exhaust are suitable for bottom duct connections only. For bottom duct, remove the sheet metal panels from the supply and return air openings through the base of the unit. For horizontal duct, remove the supply and return air panels on the rear of the unit.

All compressors include crankcase heaters and all compressors have internal pressure relief. Every refrigerant circuit includes a liquid line filter-drier, a discharge line high pressure switch and a suction line with a freezestat and low pressure/loss of charge switch. The unit control circuit includes a 75 VA transformer, a 24-volt circuit breaker and a relay board

with a compressor lockout circuit, a terminal strip for thermostat wiring, plus an additional set of pin connectors to simplify the interface of additional field controls. All units have long lasting powder paint cabinets with 1000 hour salt spray test approval under ASTM B117 procedures. All models are CSA listed. All models include a 1-year limited warranty on the complete unit. Compressors and electric heater elements carry a 5-year warranty. Aluminized steel and Stainless steel tubular heat exchangers carry a 10-year warranty.

DESCRIPTION

Units shall be factory-assembled, single packaged, Electric Cooling/Gas Heat, Electric Cooling/Optional Electric Heat and designed for outdoor mounted installation.

The 6 ton unit is rated at 10.4 EER. They shall have built-in field convertible duct connections for down discharge supply/return or horizontal discharge supply/return, and be available with factory installed options or field installed accessories. The units shall be factory wired, piped, charged with R-22 refrigerant and factory tested prior to shipment. All unit wiring shall be both numbered and color coded. All units the cooling performance shall be rated in accordance with DOE and ARI test procedures. Units shall be CSA listed, classified to ANSI Z21.47, UL 1995/CSA No. 236 standards.

UNIT CABINET

Unit cabinet shall be constructed of G90 galvanized steel, with exterior surfaces coated with a non-chalking, powdered paint finish, certified at 1000 hours salt spray test per ASTM B117 standards. Indoor blower section shall be

insulated with a minimum 1/2" thick insulation, coated on the airside. Aluminum foil faced insulation shall be used in the furnace compartment and be fastened with ridged fasteners to prevent insulation from entering the air stream. Cabinet panels shall be "large" size, easily removable for servicing and maintenance. Full perimeter base rails shall be provided to assure reliable transit of equipment, overhead rigging and proper sealing on roof curb applications. Disposable 1" filters shall be furnished and be accessible through a removable access door, sealed airtight. Units filter track shall be designed to accommodate either 1" or 2" filters. Fan performance measuring ports shall be provided on the outside of the cabinet to allow accurate air measurements of evaporator fan performance without removing panels or creating air by-pass of the coils. Condensate pan shall be internally sloped and conform to ASHRAE 62-89 self-draining standards. Condensate connection shall be a minimum of 3/4" I.D. female and be a ridged mount connection.

INDOOR (EVAPORATOR) FAN ASSEMBLY

The indoor fan shall be direct drive, multi-speed, or a factory installed belt drive assembly that includes an adjustable pitch motor pulley. Job site selected brake horsepower (B.H.P.) shall not exceed the motors nameplate horsepower rating, plus the service factor. Units shall be designed not to operate above service factor. Fan wheel shall be double-inlet type with forward-curved blades, dynamically balanced to operate smoothly throughout the entire range of operation. Airflow design shall be constant air volume. Bearings shall be sealed and permanently lubricated for longer life and no maintenance.

OUTDOOR (CONDENSER) FAN ASSEMBLY

The outdoor fan shall be of the direct-driven propeller type, discharge air vertically, have aluminum blades riveted to a corrosion resistant steel spider bracket and shall be dynamically balanced for smooth operation. The outdoor fan motor shall be totally enclosed with permanently lubricated bearings, internally protected against overload conditions and staged independently.

REFRIGERANT COMPONENTS

Compressor:

- a. Shall be internally protected with internal high-pressure relief and over temperature protection.
- b. Shall have internal spring isolation and sound muffling to minimize vibration and noise, and be externally isolated on a dedicated, independent mounting.

Coils:

- a. Evaporator and condenser coils shall have aluminum plate fins mechanically bonded to seamless internally enhanced copper tubes with all joints brazed. Special Phenolic coating shall be available as a factory option.

- b. Evaporator and Condenser coils shall be of the direct expansion, draw-thru, design.

Refrigerant Circuit and Refrigerant Safety Components shall include:

- a. Thermal expansion devices (TXV's).
 - DF072 uses a fixed orifice distributor.
- b. Filter drier/strainer to eliminate any moisture or foreign matter.
- c. Accessible service gage connections on both suction and liquid lines to charge, evacuate, and measure refrigerant pressure during any necessary servicing or troubleshooting without losing charge.
- d. The refrigeration system shall provide at least 15°F of sub-cooling at design conditions.

UNIT CONTROLS

- a. Unit shall be complete with self-contained low-voltage control circuit protected by a resettable circuit breaker on the 24-volt transformer side.
- b. Unit shall incorporate a lockout circuit which provides reset capability at the space thermostat or base unit, should any of the following standard safety devices trip and shut off compressor.
- c. Loss-of-charge/Low-pressure switch.
- d. High-pressure switch.
- e. Freeze-protection thermostat, evaporator coil.
- f. If any of the above safety devices trip, a LED (light-emitting diode) indicator shall flash a diagnostic code that indicates which safety switch has tripped.
- g. Unit shall incorporate "AUTO RESET" compressor over temperature, over current protection.
- h. Unit shall operate with conventional thermostat designs and have a low voltage terminal strip for easy hook-up.
- i. Unit control board shall have on-board diagnostics and fault code display.
- j. Standard controls shall include anti-short cycle and low voltage protection, and permit cooling operation down to 0°F.
- k. Control board shall monitor each refrigerant safety switch independently.
- l. Control board shall retain last 5 fault codes in non volatile memory, which will not be lost in the event of a power loss.

GAS HEATING SECTION (SINGLE OR 2 STAGE)

Shall be designed with induced draft combustion with post purge logic, energy saving direct spark ignition, and redundant main gas valve. Venter wheel shall be constructed of stainless steel for corrosion resistance. The heat exchanger shall be of the tubular type, constructed of T1-40 aluminized

steel for corrosion resistance and allowing minimum mixed air entering temperature of 25°F. Burners shall be of the inshot type, constructed of aluminum coated steel and contain air mixture adjustments. All gas piping shall enter the unit cabinet at a single location through either the side or curb, without any field modifications. Integrated control boards shall provide timed control of evaporator fan functioning and burner ignition. Heating section shall be provided with the following minimum protection:

- a. Primary and auxiliary high-temperature limit switches.
- b. Induced draft motor speed sensor.
- c. Flame roll out switch.
- d. Flame proving controls.
- e. If any of the above safety devices trip, a LED (light-emitting diode) indicator shall flash a diagnostic code that indicates which safety switch has tripped.

ELECTRIC HEATING SECTION

An electric heating section, with nickel chromium elements, shall be provided in a range of 5 thru 30 KW, offering two stages of capacity - 16 KW and above on 208/230 volt heaters and 20 KW and above on 460 and 575 volt heaters. The heating section shall have a primary limit control(s) and automatic reset to prevent the heating element system from operating at an excessive temperature. The heating section assembly shall slide out of the unit for easy maintenance and service. Units with Electric Heating shall be wired for a single point power supply with branch circuit fusing (where required).

UNIT OPERATING CHARACTERISTICS

- a. Unit shall be capable of starting and running at 125°F outdoor temperature, exceeding maximum load criteria of ARI Standard 210/240. The compressor, with standard controls, shall be capable of operation down to 0°F outdoor temperature. Unit shall be provided with fan time delay to prevent cold air delivery before heat exchanger warms up (Gas heat only).

ELECTRICAL REQUIREMENTS

All unit power wiring shall enter unit cabinet at a single factory provided location and be capable of side or bottom entry, to minimize roof penetrations and avoid unit field modifications. Separate side and bottom openings shall be provided for the control wiring.

STANDARD LIMITED WARRANTIES

- Compressor 5 Years
- Heat Exchanger 10 Years
- Electric Heat Element 5 Years
- Other Parts 1 Year

OPTIONAL OUTDOOR AIR (Shall be made available by either/or):

- **ELECTRONIC ENTHALPY AUTOMATIC ECONOMIZER**- Outdoor and return air dampers that are interlocked and positioned by a fully-modulating, spring return damper actuator. The maximum leakage rate for the outdoor air intake dampers shall not exceed 2% when dampers are fully closed and operating against a pressure differential of 0.5 IWG. A unit-mounted potentiometer shall be provided to adjust the outdoor and return air damper assembly to take in CFM of outdoor air to meet the minimum ventilation requirement of the conditioned space during normal operation. During economizer operation, a mixed-air temperature control shall modulate the outdoor and return air damper assembly to prevent the supply air temperature from dropping below 55°F. Changeover from compressor to economizer operation shall be provided by an integral electronic enthalpy control that feeds input into the basic module. The outdoor intake opening shall be covered with a rain hood that matches the exterior of the unit. Water eliminator/filters shall be provided. Simultaneous economizer/compressor operation is also possible. Dampers shall fully close on power loss.
- **MOTORIZED OUTDOOR AIR DAMPERS** - Outdoor air dampers are positioned by a 2-position, spring-return damper actuator. The maximum leakage rate for the outdoor air intake dampers shall not exceed 2% when dampers are fully closed and operating against a pressure differential of 0.5 IWG. A unit-mounted potentiometer shall be provided to adjust the outdoor damper assembly to take in the design CFM of outdoor air to meet the ventilation requirements of the conditioned space during normal operation. Whenever the indoor fan motor is energized, the dampers open up to one of two pre-selected positions - regardless of the outdoor air enthalpy. Dampers return to the fully closed position when the indoor fan motor is de-energized. Dampers shall fully close on power loss.

OTHER PRE-ENGINEERED ACCESSORIES AVAILABLE

- **ROOF CURB** - 14" and 8" high, full perimeter curb with wood nailer (shipped knocked-down).
- **BAROMETRIC RELIEF DAMPER** - Contains a rain hood, air inlet screen, exhaust damper and mounting hardware. Used to relieve internal air pressure through the unit.
- **PROPANE CONVERSION KIT** - Contains new orifices and gas valve parts to convert from natural to L.P. gas. One per unit required.
- **HIGH ALTITUDE - NATURAL GAS** - Contains orifices required for applications between 2000 and 6000 feet altitude.
- **HIGH ALTITUDE - PROPANE GAS** - Contains orifices required for applications between 2000 and 6000 feet altitude. Must be used with propane conversion kit.
- **LOW NOX** - Required to reduce the emission of nitrogen oxides below 40 nanograms per joule.

- **GAS PIPING** - Contains 1/2" pipe nipples, fittings and gas cock (including panel assess gaskets) required for bottom gas supply connection with external shut off.
- **POWER EXHAUST OPTION** - To work in conjunction with economizers.
- **ELECTRIC HEATERS**
- **ECONOMIZER/MOTORIZED DAMPER RAIN HOOD** - Contains all hood panels and the hardware for assembling.
- **MANUAL OUTDOOR AIR DAMPER**
- **COIL GUARD KIT** - Guard for cooling coil.
- **HAIL GUARD**
- **FLUE EXHAUST EXTENSION**

OTHER FACTORY INSTALLED OPTIONS

- **POWER EXHAUST OPTION** - To work in conjunction with economizers.
- **STAINLESS STEEL HEAT EXCHANGER**
- **STAINLESS STEEL DRAIN PAN**
- **BOTTOM DRAIN CONNECTION**

- **TECHNICOAT PHENOLIC COATED CONDENSER AND EVAPORATOR COIL**
- **ELECTRONIC SINGLE ENTHALPY ECONOMIZER**
- **DIRTY FILTER SWITCH**
- **PHASE MONITOR**
- **COIL GUARD**
- **POWERED GFI CONVENIENCE OUTLET**
- **NON-POWERED GFI CONVENIENCE OUTLET**
- **BAS CONTROLS** (Simplicity® INTELLI- Comfort™, CPC, JOHNSON, HONEYWELL, NOVAR)
- **BAS READY ECONOMIZER (2 - 10 V. D. C. ACTUATOR WITHOUT A CONTROLLER)**
- **HINGED FILTER DOOR ACCESS AND TOOLESS ACCESS PANELS**
- **2" PLEATED FILTERS**
- **DISCONNECT SWITCH**
- **SUPPLY AIR SMOKE DETECTOR**
- **RETURN AIR SMOKE DETECTOR**