

8 7 6 5 4 3 2 1

SUBMITTAL

W557 SERIES

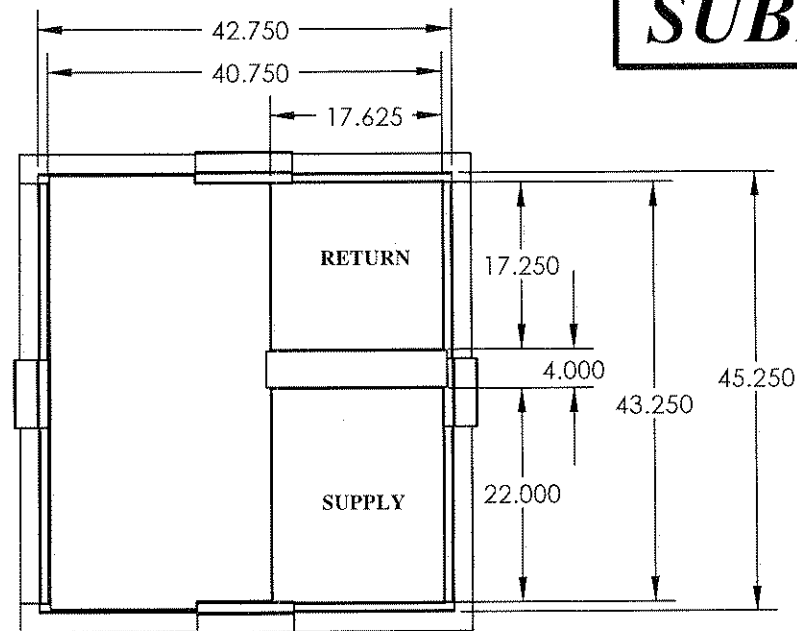
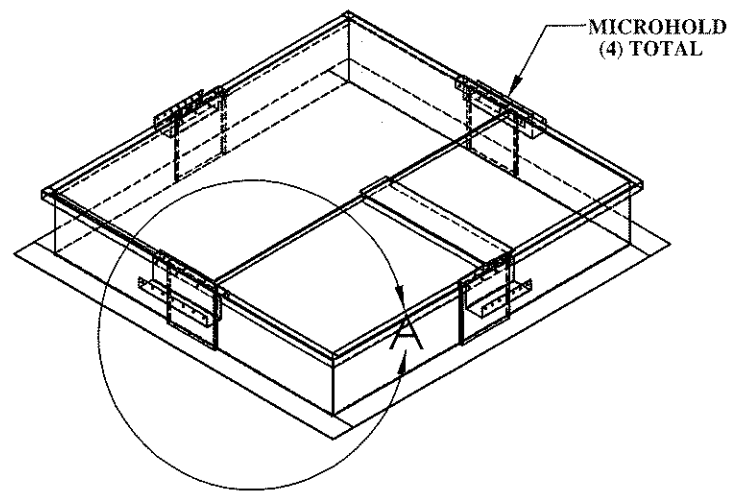

- * WELDED CONSTRUCTION
- * PERIMETER WOOD NAILER
- * GASKET PACKAGE
- * FACTORY INSTALLED HOLDDOWNS
- * INSULATED DECK PAN

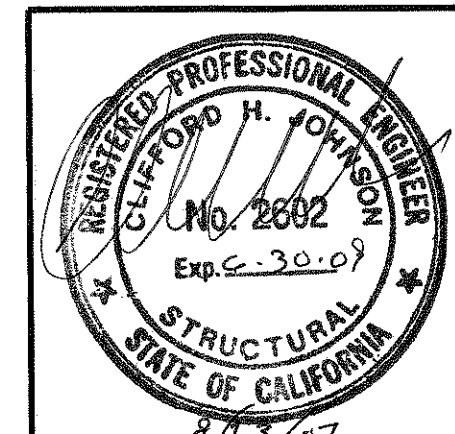
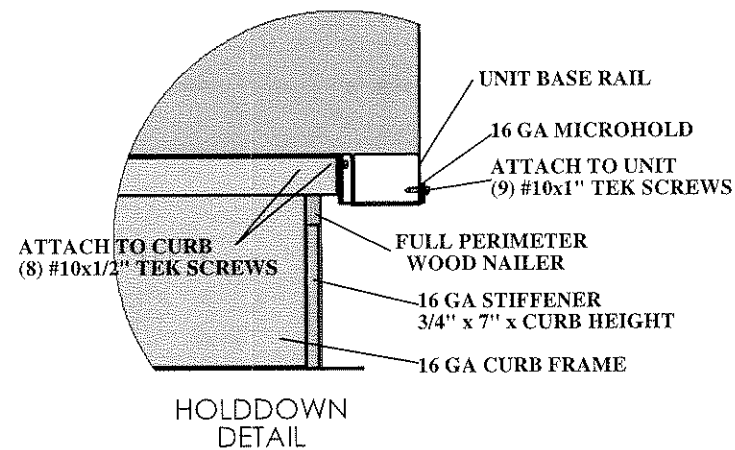
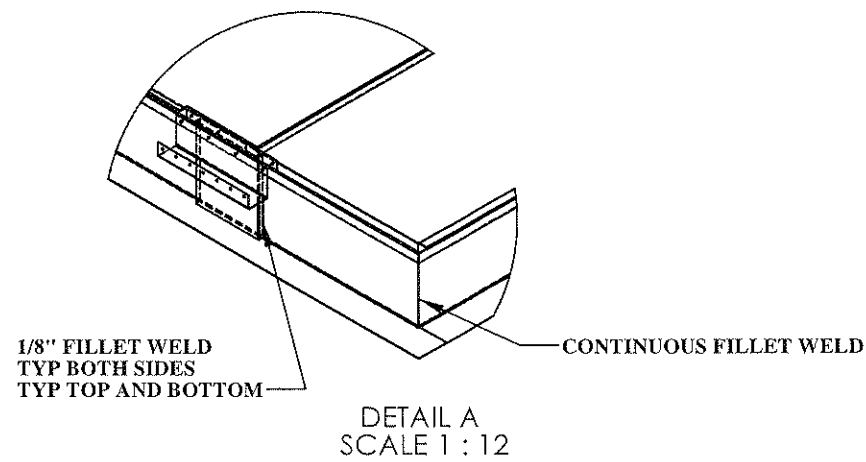
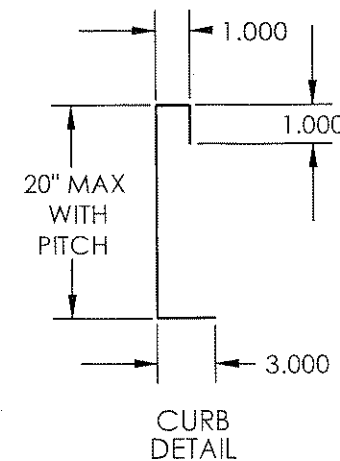

MicroMetl Corporation

PRODUCT NUMBER:
W557 SERIES
WELDED CURBS

W557-C008-01CBC 8" TALL
 W557-C011-01CBC 11" TALL
 W557-C014-01CBC 14" TALL

STRUCTURALLY CALCULATED WELDED CURB FOR YORK BHZ,BHX,DNY,DNZ,DEM 024-060 DNX 024-048, BHA,BHP,DEB,BHY,DEH,DNA,DNH 018-060

Sparks, NV. (800) 884-4662
 Indianapolis, IN. (800) 662-4822
 Longview, TX. (903) 248-4800

STEEL ATTACHMENT:
 SEE STEEL ATTACHMENT DETAIL SHEETS.

ANCHORAGE DETAILS TO ROOF:
WOOD ATTACHMENT:
 (DOUGLAS FIR)
 (40) 1/4 x 3" SIMPSON SDS W/WASHER CENTER ON CURB FLANGE, EVENLY SPACED, (10) EACH LONG SIDE, (10) EACH SHORT SIDE

CONCRETE ATTACHMENT:
 (3000 PSI MINIMUM, 4" MIN THICKNESS) (6" MIN EDGE DISTANCE)
 (12) 1/2" SIMPSON TITEN HD EVENLY SPACED, CENTER ON CURB FLANGE 8" MIN SPACING
 (3) EACH LONG SIDE, (3) EACH SHORT SIDE

DATE: 07/2007
 DRAWN BY: MAC
 WEIGHT: 65/85/115
 MEETS SEISMIC REQUIREMENTS FOR FOLLOWING CODES:
2001 CBC
2006 IBC

Structural Calculations

BJG# 20070133

Project:

W557

Prepared for:

MicroMetl Corporation
905 Southern Way
Sparks, NV 89431

Date:

August 2007



8/23/07

Curb Information Product Number 0557

h_{CURB} =	20	in - Overall height from support substrate to top of curb
L_{CURB} =	43.125	in - Longitudinal distance from center-to-center of transverse curb members
W_{CURB} =	40.75	in - Transverse distance from center-to-center of longitudinal curb members

Unit Information

W_p =	740	lbs - Max. unit weight
$W_{C_{MAX}}$ =	161	lbs - Max. corner weight
$W_{C_{MIN}}$ =	110	lbs - Min. corner weight
h_{UNIT} =	41.5	in - Overall unit height above curb
h_{CM} =	27.67	in - Height above curb to center of mass
L_{UNIT} =	49.125	in - Overall unit length (longitudinal direction)
W_{UNIT} =	47.25	in - Overall unit length (transverse direction)

Seismic Loading - 2006 International Building Code (2006 IBC)

$F_{P_{MAX}} = 1.6 * S_{DS} * I_p * W_p$

S_s =	2	(2 is worst case in NV, OR, WA, AZ)
F_a =	1	(1.0 at worst case Site D, $S_s \geq 1.25$)
S_{ms} =	2	= $F_a S_s$
S_{DS} =	1.33	= $2/3 S_{ms}$
I_p =	1.5	(1.5 at worst case Occupancy)
$F_{P_{MAX}}$ =	3.20	W_p
$F_{P_{MAX}}$ =	2.29	W_p (ASD)
$F_{P_{MAX}}$ =	1691	lb (ASD) - ASD values will be used throughout unless noted otherwise

Seismic Loading - 2001 California Building Code (2001 CBC)

$F_{P_{MAX}} = 4 * C_a * I_p * W_p$

C_a =	0.44	(.44 at worst case at Zone 4, Soil Type Sd)
N_a =	1.5	(1.5 at worst case Seismic Source Type A ≤ 2 km)
I_p =	1.5	(1.5 at worst case Occupancy)
$F_{P_{MAX}}$ =	3.96	W_p
$F_{P_{MAX}}$ =	2.83	W_p (ASD)
$F_{P_{MAX}}$ =	2093	lb (ASD) - ASD values will be used throughout unless noted otherwise

Controlling Seismic Loads

$F_{P_{MAX}}$ =	2.83	W_p (ASD)
$F_{P_{MAX}}$ =	2093	lb (ASD) - ASD values will be used throughout unless noted otherwise

Wind Loading Check

Max. Projected Area (A_{MAX}) = $h_{UNIT} * \text{MAX}(L_{UNIT} \text{ or } W_{UNIT})$

$$A_{MAX} = \begin{matrix} 2039 & \text{in}^2 \\ 14.2 & \text{ft}^2 \end{matrix}$$

Equivalent wind pressure required to equal seismic loading (P_{EQ}) = $F_{P_{MAX}} / A_{MAX}$

$$P_{EQ} = 119 \text{ psf (ASD) OKAY BY INSPECTION: } P > 60 \text{ PSF}$$

$V_{\text{each side}} = 2/3 * F_{p\text{MAX}} \text{ (ASD)}$
 $V_{\text{MAX}} = \boxed{1395} \text{ lb per side}$

Transverse Loading

$\text{Max } \downarrow = 2 W_{C\text{MAX}} + F_{p\text{max}} * (h_{cm} + h_{curb}) / W_{curb}$

$\text{Max } \downarrow = \boxed{2770} \text{ lb per side}$

$\text{Max } \uparrow = F_{p\text{max}} * (h_{cm} + h_{curb}) / W_{curb} - 2 * W_{C\text{MIN}}$

$\text{Max } \uparrow = \boxed{2228} \text{ lb - Uplift per side}$

Longitudinal Loading

$\text{Max } \downarrow = 2 W_{C\text{MAX}} + F_{p\text{max}} * (h_{cm} + h_{curb}) / L_{curb}$

$\text{Max } \downarrow = \boxed{2636} \text{ lb per end}$

$\text{Max } \uparrow = F_{p\text{max}} * (h_{cm} + h_{curb}) / (L_{curb} - 15") - 2 * W_{C\text{MIN}}$

$\text{Max } \uparrow = \boxed{3327} \text{ lb - Uplift per end}$

Frame Assembly Stiffeners

Use 16 gage stiffener material

Conditions and formulas per AISI Cold-Formed Steel Specification (2001)

t =	0.060	in
Fy =	33	ksi
Length =	7	in
Width =	0.75	in
Height =	20	in
$\Omega_c =$	1.8	
A =	0.50	in ²
r ₁ =	0.34	in
r ₂ =	2.32	in
kl/r _{min} =	59.0	
E =	29000	ksi

$F_e = \pi^2 E / (KL/r)^2$

$F_e = \boxed{82.18} \text{ ksi} \quad (\text{Eq. C4.1-1})$

$\lambda_c = \sqrt{F_y / F_e}$

$\lambda_c = \boxed{0.63} \quad (\text{Eq. C4-4})$

$F_n = \boxed{19.42} \text{ ksi} \quad (\text{Eq. C4-2,3})$

$P_n = A_g F_n$

$P_n = \boxed{9.76} \text{ kips} \quad (\text{Eq. C4-1})$

$P_n / \Omega_c = \boxed{5.42} \text{ kips}$

$P_U = R_{MAX}$

$P_U = \boxed{2770.42} \text{ lbs}$

$P_U = \boxed{2.77} \text{ kips}$

STIFFENER OKAY

Connections

Use Self-drilling, Self Tapping Steel Screws typical & use A307 bolts

Use fastener type #10 in No. 16 gage materials minimum at hold-down to unit and curb.

Allowable Shear = $\boxed{403}$ lb per each

Use 1/4" diam. bolts in No. 16 gage materials minimum at corner connectors.

Allowable Shear = $\boxed{654}$ lb per each

Allowable Tension = $\boxed{1176}$ lb per each

Hold-down Connectors

Resultant Force from Vmax and Max $\uparrow = \boxed{3609} = ((V_{\text{max}})^2 + (\text{Max } \uparrow)^2)^{1/2}$

Total Screws required at connectors = $\boxed{9} = \text{Resultant} / 1 \text{ connectors per side} / \text{allowable Shear}$

Anchorage to Supporting Structure

Shear to each long side = lbs
 Shear to each short side = lbs

Transverse Loading

Max ↑ = $F_p \max * (h_{cm} + h_{curb}) / W_{curb} - 2 * W_{C_{MIN}}$
 Max ↑ = 2228 lb - Uplift per side

Longitudinal Loading

Max ↑ = $F_p \max * (h_{cm} + h_{curb}) / (L_{curb} - 9") - 2 * W_{C_{MIN}}$
 Max ↑ = 2704 lb - Uplift per end

Anchorage to Concrete Pad

4 in. thick concrete pad - min. embedment of 3 in., min. spacing of 8 in. and min. edge distance of 6 in.

w/ 1/2" Simpson Titen HD, allow = lbs in shear
 w/ 1/2" Simpson Titen HD, allow = lbs in tension

Try Titen HD's per long side at a minimum
 Try Titen HD's per short side

$(\text{Actual Shear} / \text{Allowable Shear})^{5/3} + (\text{Actual Tension} / \text{Allowable Tension})^{5/3} \leq 1.0$

Elliptical Interaction Equation = at the long sides **OK, less than 1.0**
 Elliptical Interaction Equation = at the short sides **OK, less than 1.0**

Anchorage to Wood sub-Structure

With Simpson 1/4 x 3" SDS screws...

Allow Shear = lb per simpson catalog
 Allow Tension = lb assuming 2" penetration per NDS Table 11.2B (#14 wood screw)

screws required for uplift long side
 screws required for uplift short side
 screws required for shear both sides

total screws required long side inches maximum spacing
 total screws required short side inches maximum spacing

Anchorage to Steel sub-Structure

The steel sub-structure will have wood blocking in place between flutes of metal deck, therefore the required number of SDS screws will be the same as for the wood sub-structure.