

SUBMITTAL W565 SERIES

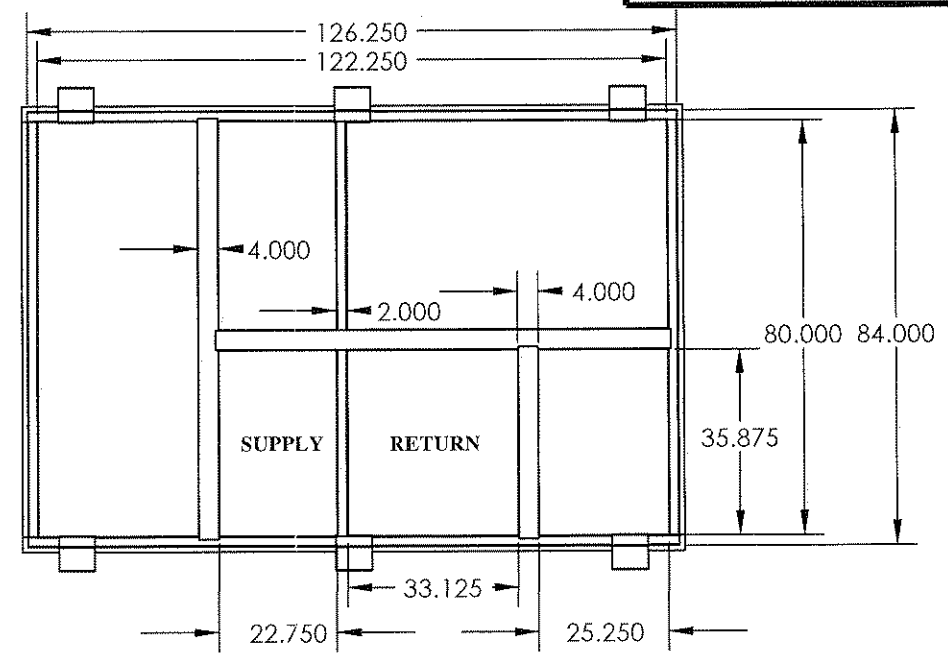

- * WELDED CONSTRUCTION
- * PERIMETER WOOD NAILER
- * GASKET PACKAGE
- * FACTORY INSTALLED HOLDDOWNS

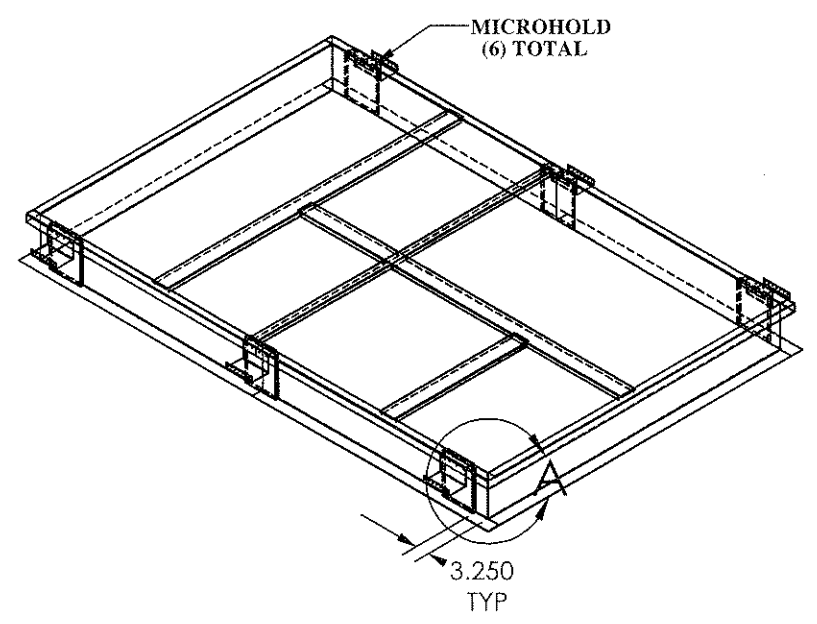
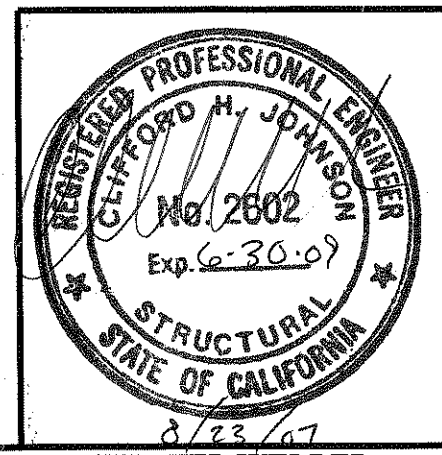
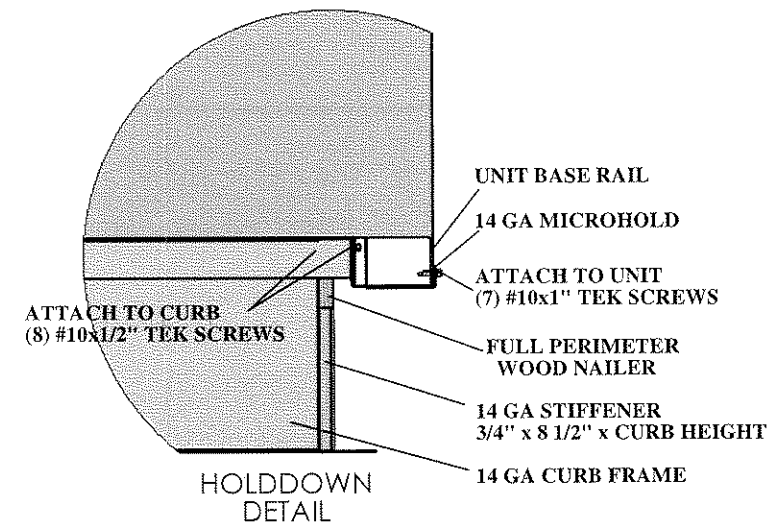
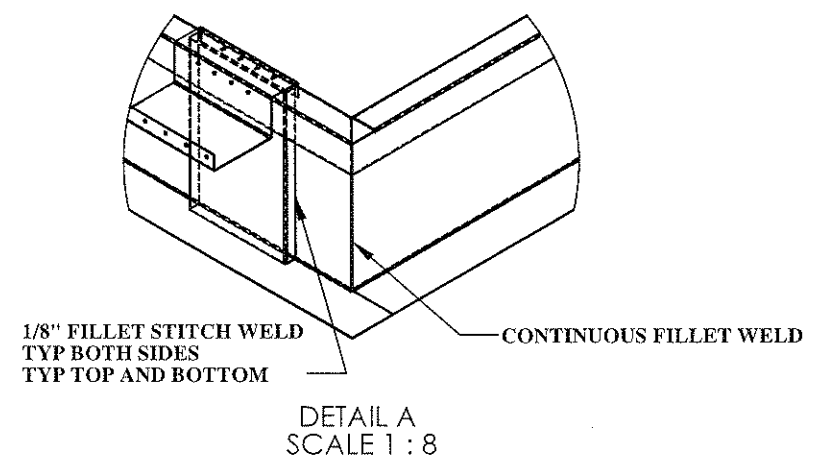
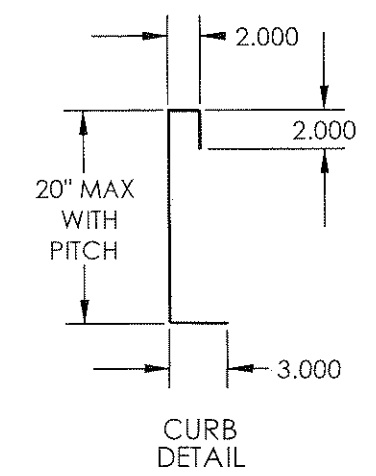

MicroMetl Corporation **PRODUCT NUMBER:** W565-C008-01CBC 8" TALL **STRUCTURALLY CALCULATED WELDED CURB FOR YORK DJ, DR, 180-300 DCE, DCG, DM 240-300 BCH, DEG, DEE, BP 240 UNITS**
W565 SERIES W565-C011-01CBC 11" TALL
WELDED CURBS W565-C014-01CBC 14" TALL

Sparks, NV. (800) 884-4662
Indianapolis, IN. (800) 662-4822
Longview, TX. (903) 248-4800

ANCHORAGE DETAILS TO ROOF:
STEEL ATTACHMENT:
 SEE STEEL ATTACHMENT DETAIL SHEETS.

WOOD ATTACHMENT:
 (DOUGLAS FIR)
 (86) 1/4 x 3" SIMPSON SDS W/WASHER CENTER ON CURB FLANGE, EVENLY SPACED, (23) EACH LONG SIDE, (20) EACH SHORT SIDE

CONCRETE ATTACHMENT:
 (3000 PSI MINIMUM, 4" MIN THICKNESS) (6" MIN EDGE DISTANCE)
 (24) 1/2" SIMPSON TITEN HD EVENLY SPACED, CENTER ON CURB FLANGE 8" MIN SPACING (7) EACH LONG SIDE, (5) EACH SHORT SIDE

DATE: 07/2007
 DRAWN BY: MAC
 WEIGHT: 250/286/310
 MEETS SEISMIC REQUIREMENTS FOR FOLLOWING CODES:
 2001 CBC
 2006 IBC

Structural Calculations

BJG# 20070133

Project:

W565

Prepared for:

MicroMetl Corporation

905 Southern Way
Sparks, NV 89431

Date:

August 2007





Reno
Las Vegas

ARCHITECTURE + ENGINEERING

Blakely, Johnson & Ghushn Inc.
6995 Sierra Center Parkway Suite 200
Reno, Nevada 89511
775.827.1010
775.827.1663 (fax)
www.bjginc.com

Job#: 20070133
By: TRH
Date: 8/21/2007
Page: 1

Curb Information

Product Number 0565

$h_{CURB} =$	20	in - Overall height from support substrate to top of curb
$L_{CURB} =$	122.25	in - Longitudinal distance from center-to-center of transverse curb members
$W_{CURB} =$	80	in - Transverse distance from center-to-center of longitudinal curb members

Unit Information

$W_p =$	3085	lbs - Max. unit weight
$W_{C_{MAX}} =$	794	lbs - Max. corner weight
$W_{C_{MIN}} =$	509	lbs - Min. corner weight
$h_{UNIT} =$	52.625	in - Overall unit height above curb
$h_{CM} =$	35.08	in - Height above curb to center of mass
$L_{UNIT} =$	136.25	in - Overall unit length (longitudinal direction)
$W_{UNIT} =$	92	in - Overall unit length (transverse direction)

Seismic Loading - 2006 International Building Code (2006 IBC)

$F_{P_{MAX}} = 1.6 * S_{DS} * I_p * W_p$

$S_s =$	2	(2 is worst case in NV, OR, WA, AZ)
$F_a =$	1	(1.0 at worst case Site D, $S_s \geq 1.25$)
$S_{ms} =$	2	= $F_a S_s$
$S_{DS} =$	1.33	= $2/3 S_{ms}$
$I_p =$	1.5	(1.5 at worst case Occupancy)
$F_{P_{MAX}} =$	3.20	W_p
$F_{P_{MAX}} =$	2.29	W_p (ASD)
$F_{P_{MAX}} =$	7051	lb (ASD) - ASD values will be used throughout unless noted otherwise

Seismic Loading - 2001 California Building Code (2001 CBC)

$F_{P_{MAX}} = 4 * C_a * I_p * W_p$

$C_a =$	0.44	(.44 at worst case at Zone 4, Soil Type Sd)
$N_a =$	1.5	(1.5 at worst case Seismic Source Type A <= 2km)
$I_p =$	1.5	(1.5 at worst case Occupancy)
$F_{P_{MAX}} =$	3.96	W_p
$F_{P_{MAX}} =$	2.83	W_p (ASD)
$F_{P_{MAX}} =$	8726	lb (ASD) - ASD values will be used throughout unless noted otherwise

Controlling Seismic Loads

$F_{P_{MAX}} =$	2.83	W_p (ASD)
$F_{P_{MAX}} =$	8726	lb (ASD) - ASD values will be used throughout unless noted otherwise

Wind Loading Check

Max. Projected Area (A_{MAX}) = $h_{UNIT} * \text{MAX}(L_{UNIT} \text{ or } W_{UNIT})$

$$A_{MAX} = \frac{7170}{49.8} \begin{matrix} \text{in}^2 \\ \text{ft}^2 \end{matrix}$$

Equivalent wind pressure required to equal seismic loading (P_{EQ}) = $F_{P_{MAX}} / A_{MAX}$

$$P_{EQ} = \frac{142}{\text{psf (ASD)}} \text{ OKAY BY INSPECTION: } P > 60 \text{ PSF}$$

$V_{\text{each side}} = 2/3 * F_{p\text{MAX}} \text{ (ASD)}$
 $V_{\text{MAX}} = \boxed{5817}$ lb per side

Transverse Loading

$\text{Max } \downarrow = 2 W_{C\text{MAX}} + F_{p\text{max}} * (h_{cm} + h_{curb}) / W_{curb}$

Max $\downarrow = \boxed{7596}$ lb per side

$\text{Max } \uparrow = F_{p\text{max}} * (h_{cm} + h_{curb}) / W_{curb} - 2 * W_{C\text{MIN}}$

Max $\uparrow = \boxed{4990}$ lb - Uplift per side

Longitudinal Loading

$\text{Max } \downarrow = 2 W_{C\text{MAX}} + F_{p\text{max}} * (h_{cm} + h_{curb}) / L_{curb}$

Max $\downarrow = \boxed{5520}$ lb per end

$\text{Max } \uparrow = F_{p\text{max}} * (h_{cm} + h_{curb}) / (L_{curb} - 15") - 2 * W_{C\text{MIN}}$

Max $\uparrow = \boxed{3464}$ lb - Uplift per end

Frame Assembly Stiffeners

Use 14 gage stiffener material

Conditions and formulas per AISI Cold-Formed Steel Specification (2001)

t =	0.105	in
F _y =	33	ksi
Length =	6	in
Width =	0.75	in
Height =	20	in
Ω _c =	1.8	
A =	0.77	in ²
r ₁ =	0.33	in
r ₂ =	2.00	in
kl/r _{min} =	61.3	
E =	29000	ksi

$F_e = \pi^2 E / (KL/r)^2$		
F _e =	76.15	ksi (Eq. C4.1-1)
$\lambda_c = \sqrt{F_y / F_e}$		
λ _c =	0.66	(Eq. C4-4)
F _n =	19.02	ksi (Eq. C4-2,3)
P _n = A _e F _n		
P _n =	14.56	kips (Eq. C4-1)
P _n /Ω _c =	8.09	kips
P _U = R _{MAX}		
P _U =	7596.31	lbs
P _U =	7.60	kips

STIFFENER OKAY

Connections

Use Self-drilling, Self Tapping Steel Screws typical & use A307 bolts

Use fastener type #10 in No. 16 gage materials minimum at hold-down to unit and curb.

Allowable Shear = **403** lb per each

Use 1/4" diam. bolts in No. 16 gage materials minimum at corner connectors.

Allowable Shear = **654** lb per each

Allowable Tension = **1176** lb per each

Hold-down Connectors

Resultant Force from Vmax and Max $\uparrow = \boxed{7665} = ((V_{\text{max}})^2 + (\text{Max } \uparrow)^2)^{1/2}$

Total Screws required at connectors = **7** = Resultant / 3 connectors per side / allowable Shear

Anchorage to Supporting Structure

Shear to each long side = lbs
 Shear to each short side = lbs

Transverse Loading

Max ↑ = $F_p \max * (h_{cm} + h_{curb}) / W_{curb} - 2 * W_{C_{MIN}}$
 Max ↑ = 4990 lb - Uplift per side

Longitudinal Loading

Max ↑ = $F_p \max * (h_{cm} + h_{curb}) / (L_{curb} - 9") - 2 * W_{C_{MIN}}$
 Max ↑ = 3226 lb - Uplift per end

Anchorage to Concrete Pad

4 in. thick concrete pad - min. embedment of 3 in., min. spacing of 8 in. and min. edge distance of 6 in.

w/ 1/2" Simpson Titen HD, allow = lbs in shear
 w/ 1/2" Simpson Titen HD, allow = lbs in tension

Try Titen HD's per long side at a minimum
 Try Titen HD's per short side

$(\text{Actual Shear} / \text{Allowable Shear})^{5/3} + (\text{Actual Tension} / \text{Allowable Tension})^{5/3} \leq 1.0$

Elliptical Interaction Equation = at the long sides **OK, less than 1.0**
 Elliptical Interaction Equation = at the short sides **OK, less than 1.0**

Anchorage to Wood sub-Structure

With Simpson 1/4 x 3" SDS screws...

Allow Shear = lb per simpson catalog
 Allow Tension = lb assuming 2" penetration per NDS Table 11.2B (#14 wood screw)

screws required for uplift long side
 screws required for uplift short side

screws required for shear both sides

total screws required long side inches maximum spacing
 total screws required short side inches maximum spacing

Anchorage to Steel sub-Structure

The steel sub-structure will have wood blocking in place between flutes of metal deck, therefore the required number of SDS screws will be the same as for the wood sub-structure.